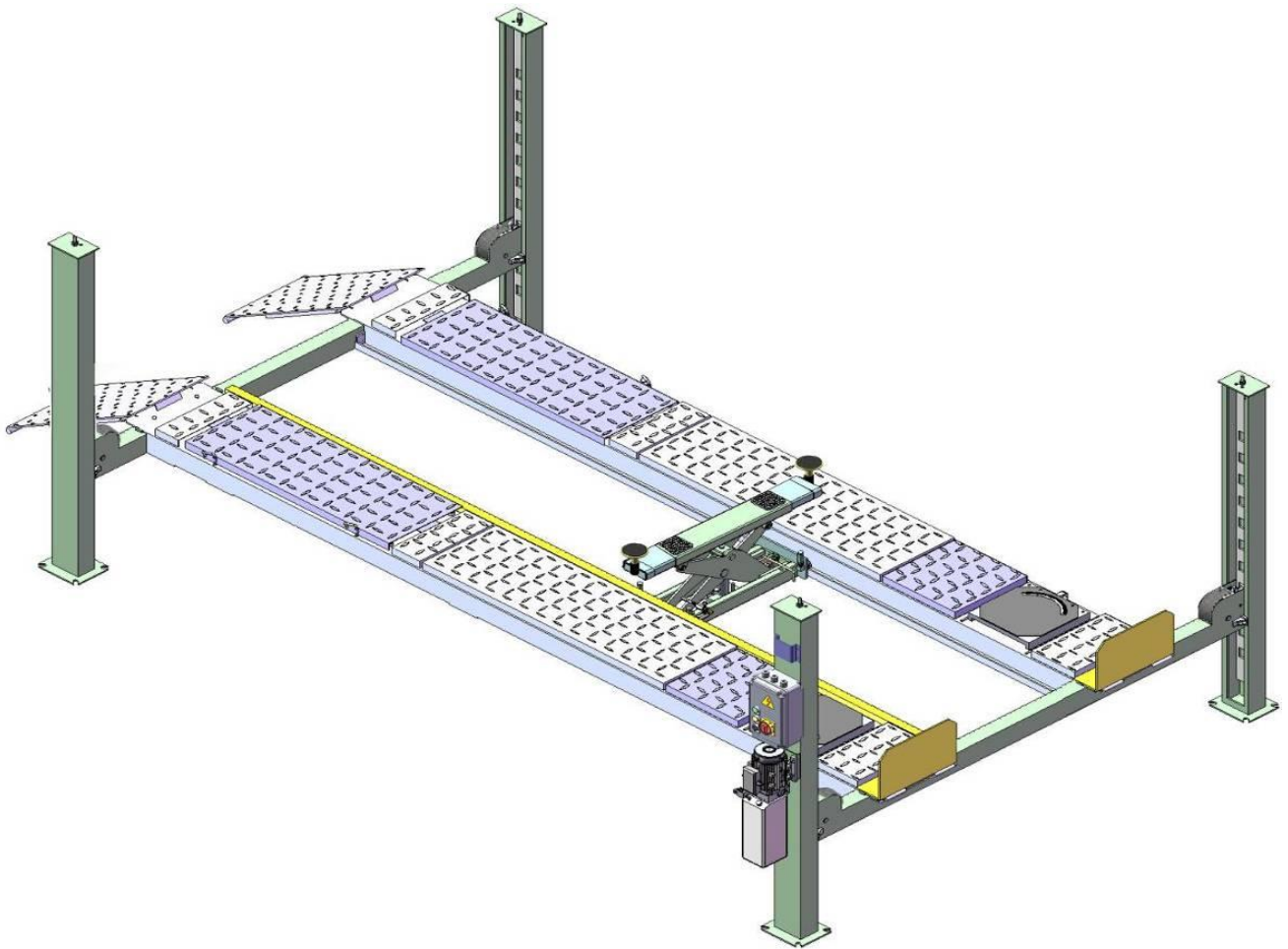




# **INDYPRO**

## **LIFTS & EQUIPMENT**



**FOUR-POST LIFT**  
**Model: TFP09A**

# CONTENTS

Product Features and Specifications .....	1
Installation Requirement .....	2
Steps of Installation .....	3
Exploded View .....	31
Test Run .....	36
Operation Instruction .....	38
Maintenance .....	39
Trouble Shooting .....	40
Parts List .....	41

## I. PRODUCT FEATURES AND SPECIFICATIONS

### ALIGNMENT 4-POST MODEL TFP09A FEATURES

- Electric-air control operation system.
- Mechanical self-lock and air-driven safety release.
- Electrical hydraulic power system, cable-driven.
- Non-skid diamond platforms.
- Multiple turnplate pockets fit with different wheel base.
- Adjustable platform and adjustable safety lock ladders.
- Optional Jack: With hand pump/Air-operated hydraulic pump/Controlled by power unit.
- Optional Turnplates

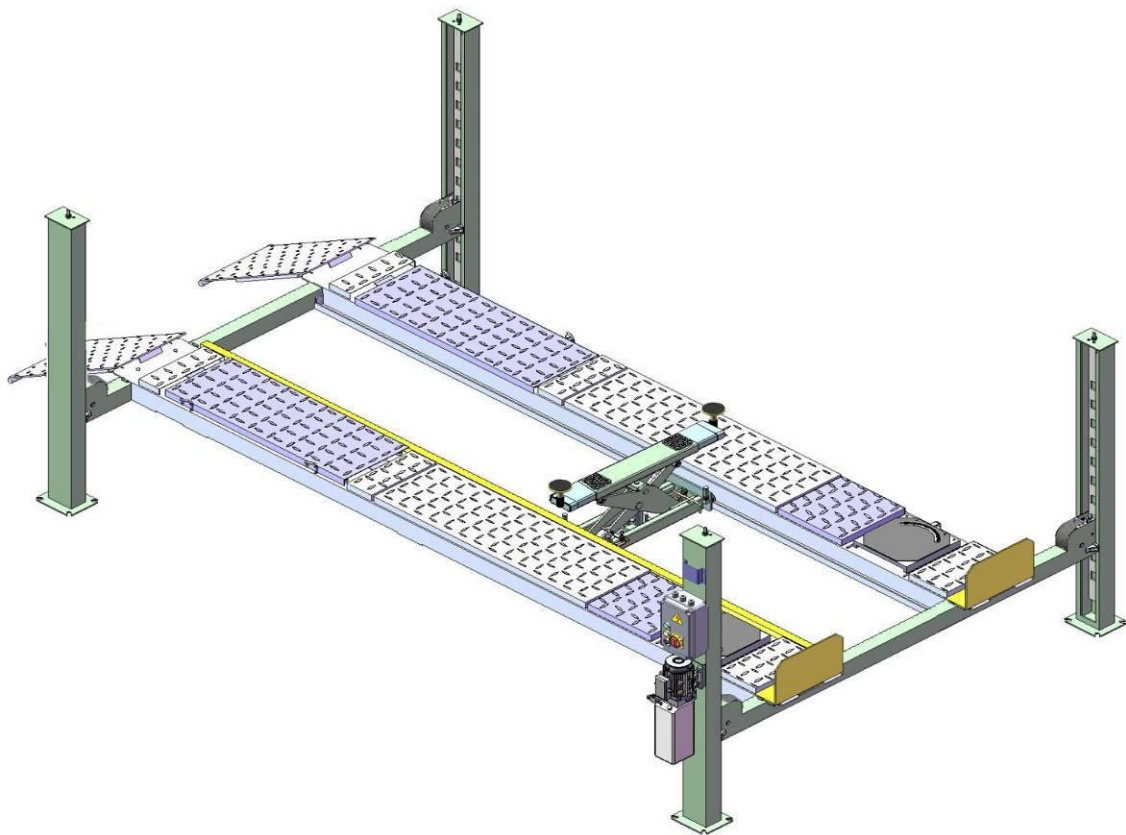


Fig. 1

### ALIGNMENT MODEL TFP09A SPECIFICATIONS

Model	Lifting Capacity	Lifting Height	Lifting Time	Overall Length (Inc. Ramps)	Overall Length (No Ramps)	Overall Width	Width Between Columns	Gross Weight	Motor
TFP09A	4.0T	1915mm	45S	5512mm	4600mm	3208mm	2852 mm	1145 Kg	2.0/3.0 HP
	9,000 lbs	75 3/8"		217"	181 1/8"	126 1/4"	112 1/4"	2522 lbs	

## II. INSTALLATION REQUIREMENT

### A. TOOLS REQUIRED

- ✓ Rotary Hammer Drill ( $\Phi 19$ )



- ✓ Hammer



- ✓ Level Bar



- ✓ English Spanner (12")



- ✓ Ratchet Spanner With Socket (28#)



- ✓ Wrench Set

(10#, 12#, 13#, 14#, 17#, 19#, 24#, 30#)



- ✓ Carpenter's Chalk



- ✓ Screw Sets



- ✓ Tape Measure (7.5m)



- ✓ Pliers



- ✓ Socket Head Wrench (3#, 5#, 6#)



- ✓ Lock Wrench

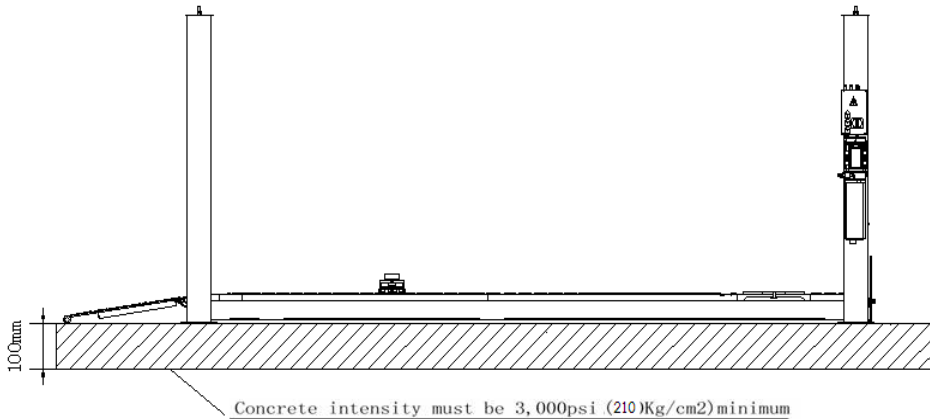


Fig. 2

## B. SPECIFICATIONS OF CONCRETE (See Fig. 3)

**Specifications of concrete must be adhered to the specification as following. Failure to do so may result in lift and/or vehicle falling.**

1. Concrete must be thickness 100mm minimum and without reinforcing steel bars, and must be dried totally before the installation.
2. Concrete must be in good condition and must be of test strength 3,000psi (210kg/cm<sup>2</sup>) minimum.
3. Floors must be level and no cracks.



**Fig. 3**

## C. AIR SUPPLY

Air pressure requirement: 0.5Mpa~0.8Mpa, Air line size  $\phi 8 \times \phi 6$  and  $\phi 6 \times \phi 4$ .

## D. POWER SUPPLY

The electrical source must be 3HP minimum. The source cable size must be 2.5mm<sup>2</sup> and in good condition of contacting with floor.

## III. STEPS OF INSTALLATION

### A. Location of installation

Check and insure the installation location (concrete, layout, space size etc.) is suitable for lift installation.

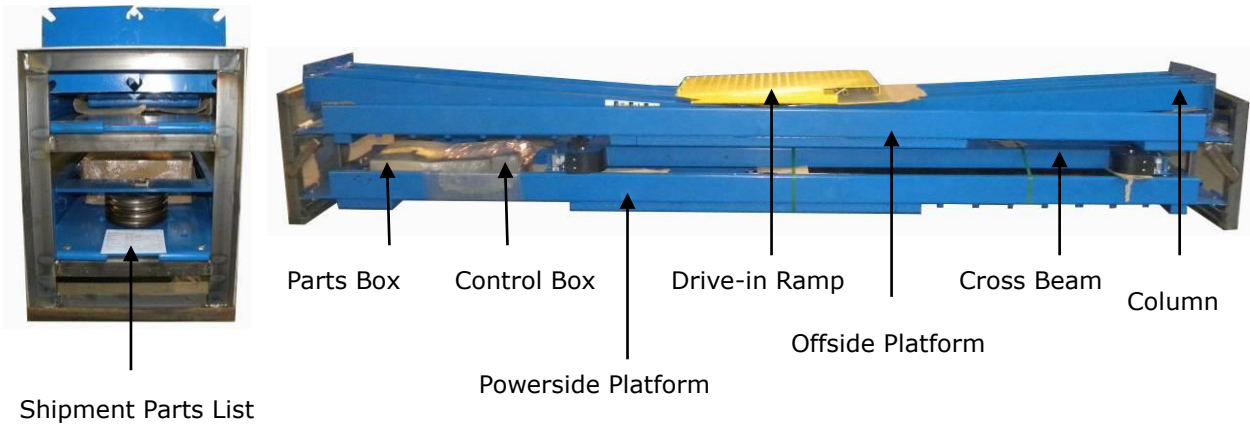
### B. Check the parts before assembly

1. Packaged lift and hydraulic power unit (See Fig. 4).



**Fig. 4**

2. Open the outer packing carefully (See Fig. 5).



**Fig. 5**

3. Take off the drive-thru ramps and columns (See Fig. 6).



**Fig. 6**

4. Loose the screws of the upper package stand, take off the offside platform, take out the parts inside the powerside platform, than remove the package stand.

5. Move aside the parts and check the parts according to the shipment parts list (See Fig. 7).



**Fig. 7**

73



6. Open the carton of parts and check the parts according to the parts box list (See Fig. 8).



Fig. 8

7. Check the parts of the parts bag according to the parts bag list (See Fig. 9).

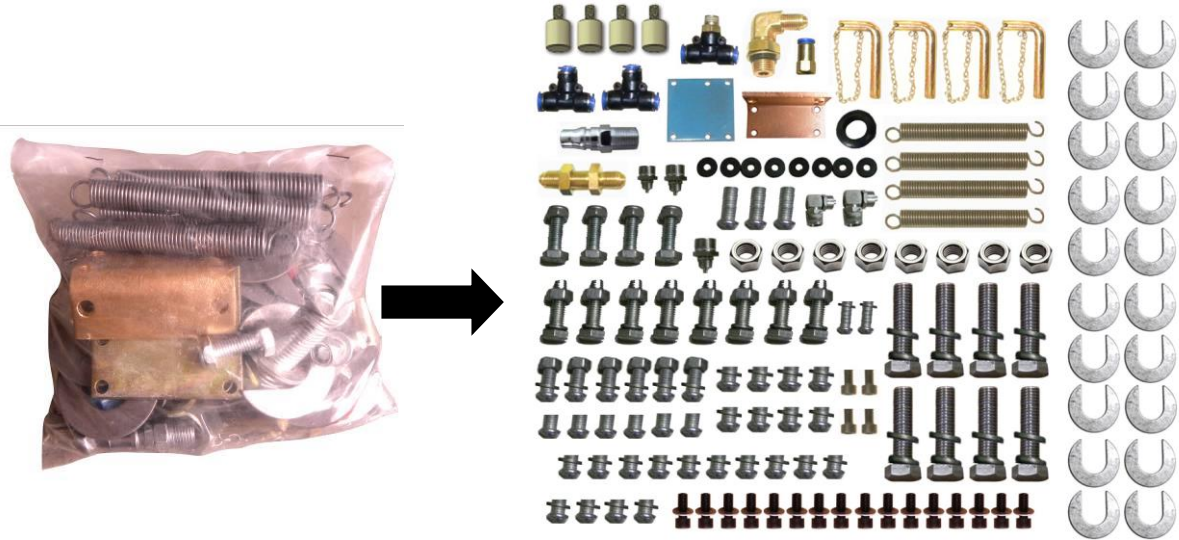
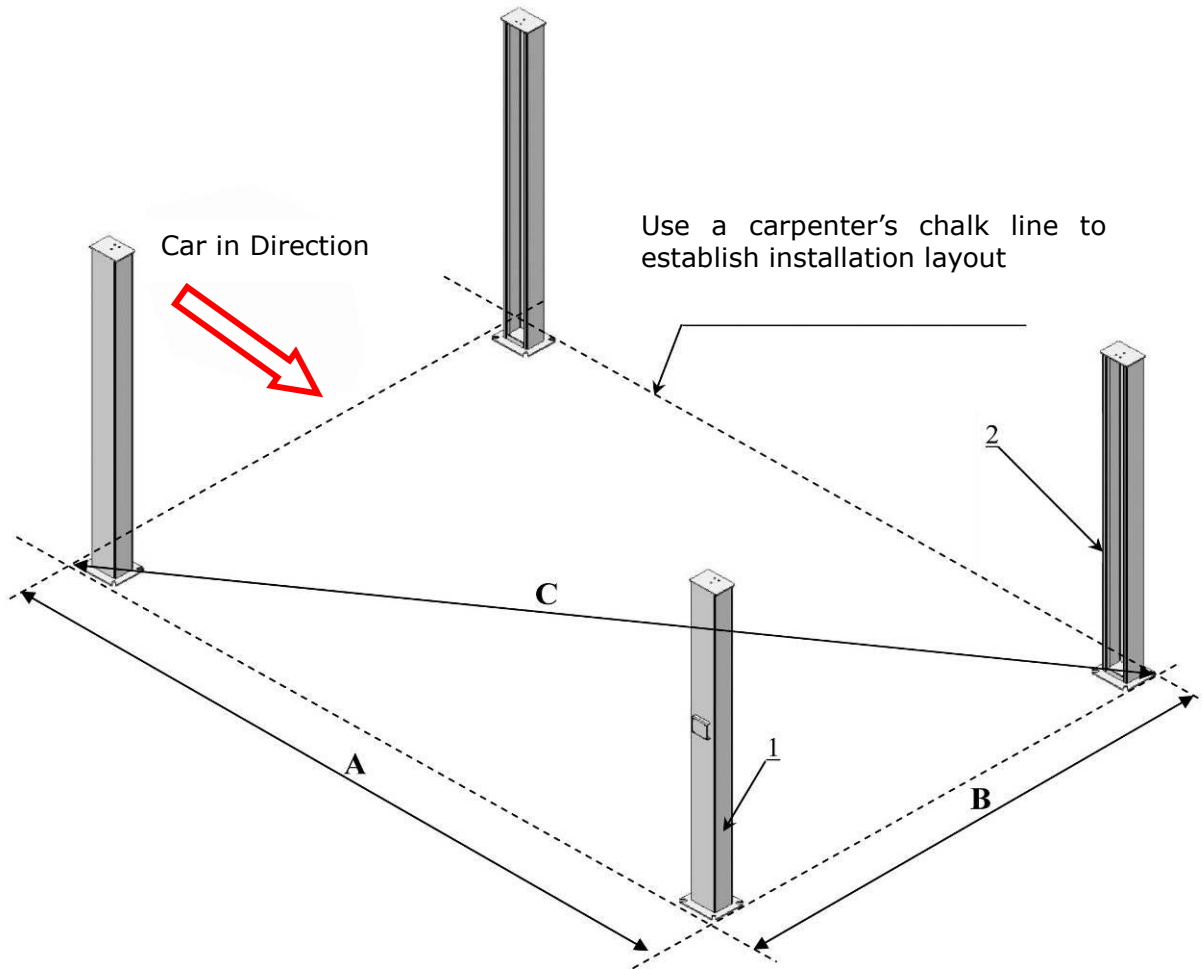


Fig. 9

C. Use a carpenter's chalk line to establish installation layout as per Table 1  
 Make sure the size is right and base is flat (**see Fig. 10**).

**Note: Reserve space front and behind the installation site.**



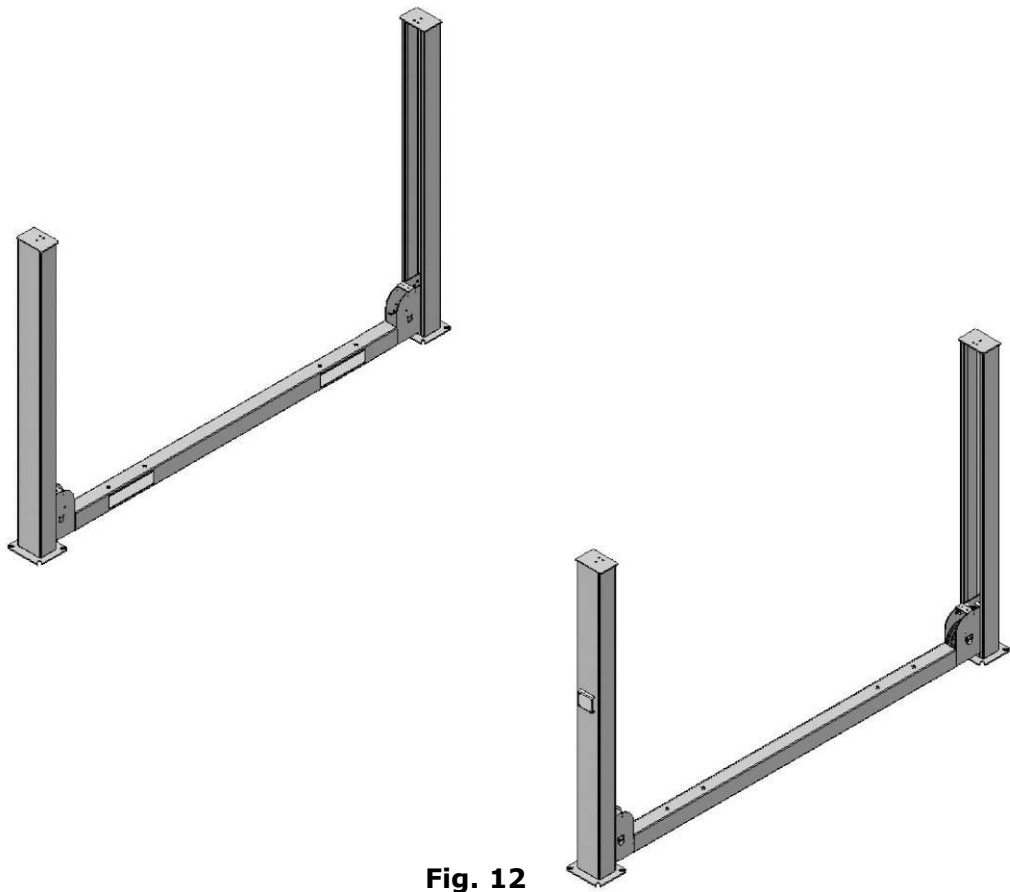
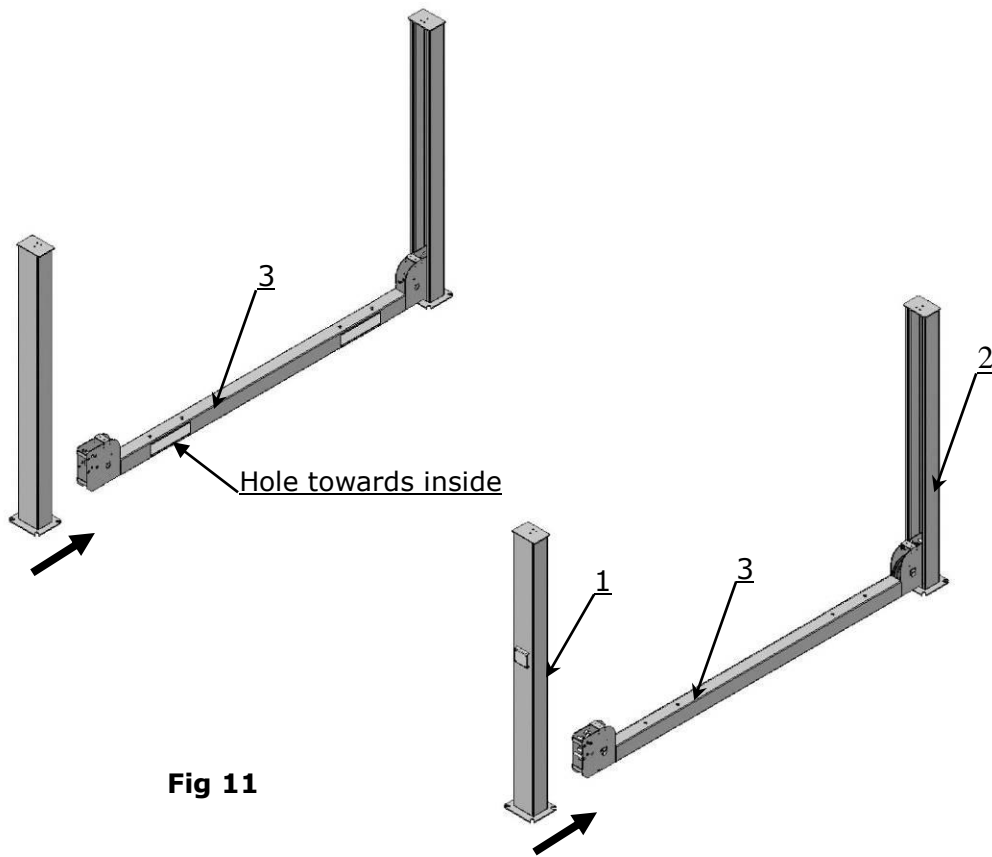
**Fig. 10**

MODEL	A	B	C	REMARK
TFP09A	4600mm 181"	3208mm 126 1/4"	5608mm 220 3/4"	

**Table 1**



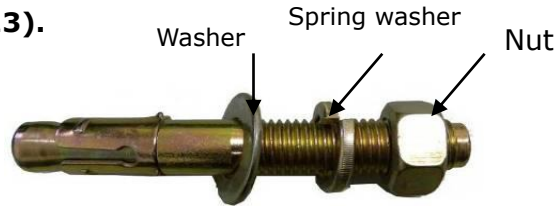
**D. Install cross beams (See Fig. 11, Fig. 12).**



## E. Fix the anchor bolts

1. Prepare the anchor bolts (See Fig. 13).

Fig. 13



2. Using the prescribed rotary hammer drill, and drill all the anchor holes and install the anchor bolts. Do not tighten the anchor bolts (See Fig. 14).

**Note: Anchor bolts driven into the ground at least 90mm**

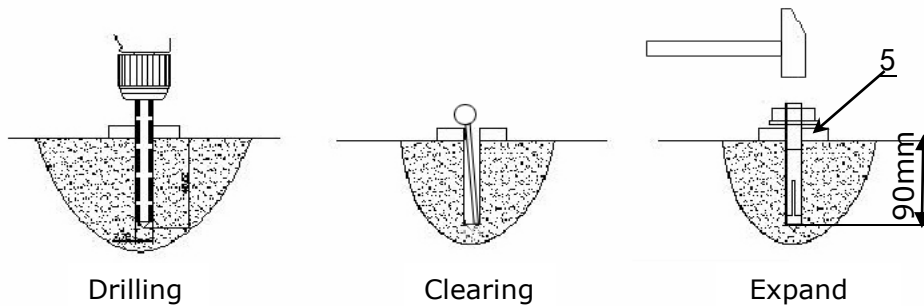


Fig. 14

## F. Install the safety ladders

1. Take off the pulley safety cover and unscrew the four upper nuts of the Safety ladders, and then adjust the four lower nuts to be at the same position. Withdraw the Slack-cable safety lock of the cross-beam to insert the safety ladder in, raise the safety ladder, and screw the upper nuts (See Fig. 15).

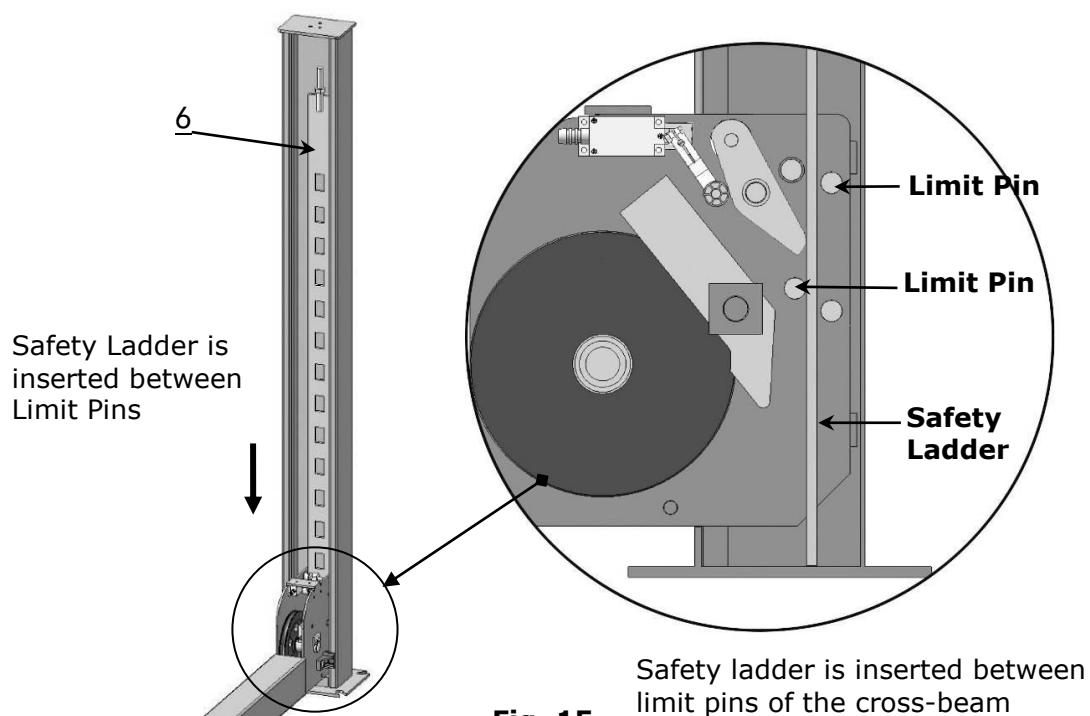
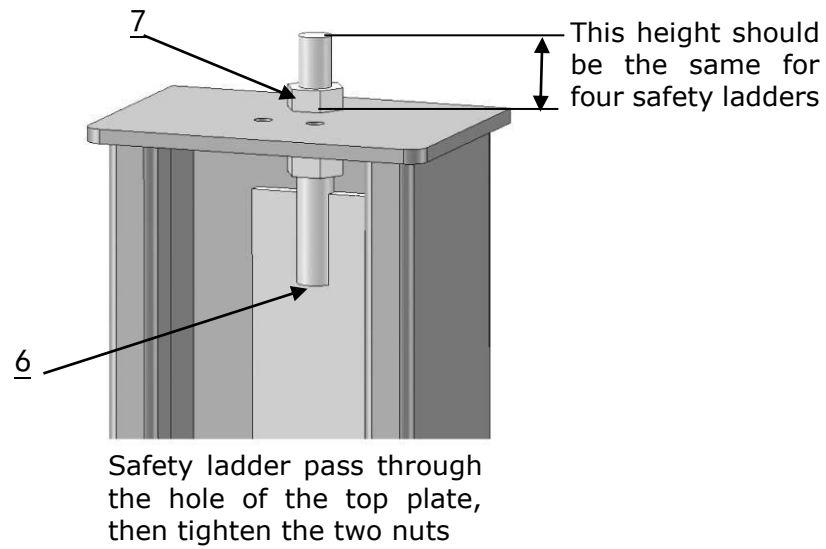


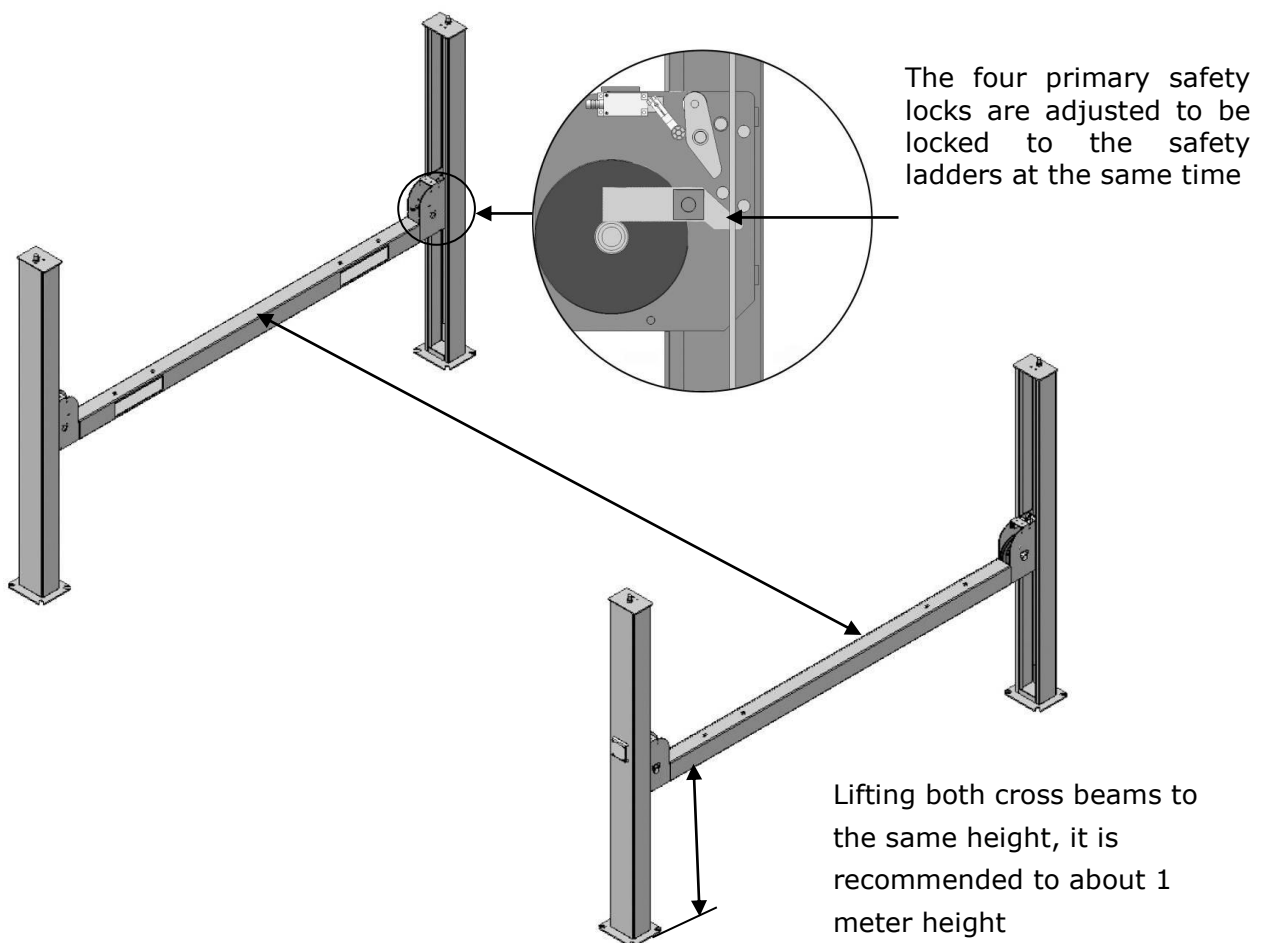
Fig. 15

2. Install safety ladders (See Fig. 16).



**Fig. 16**

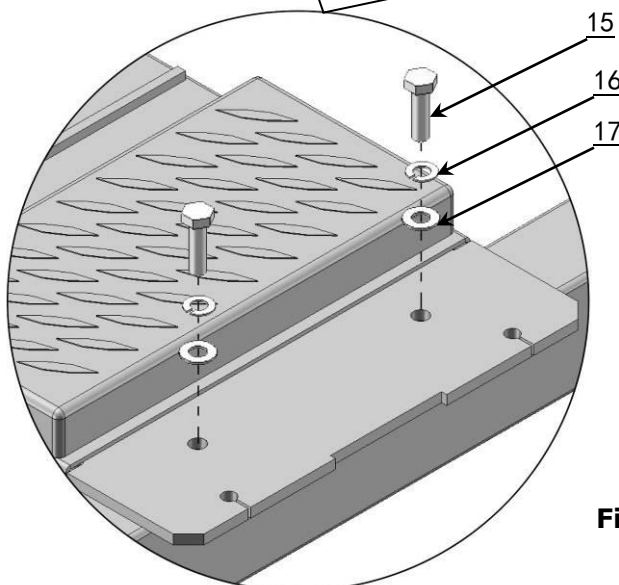
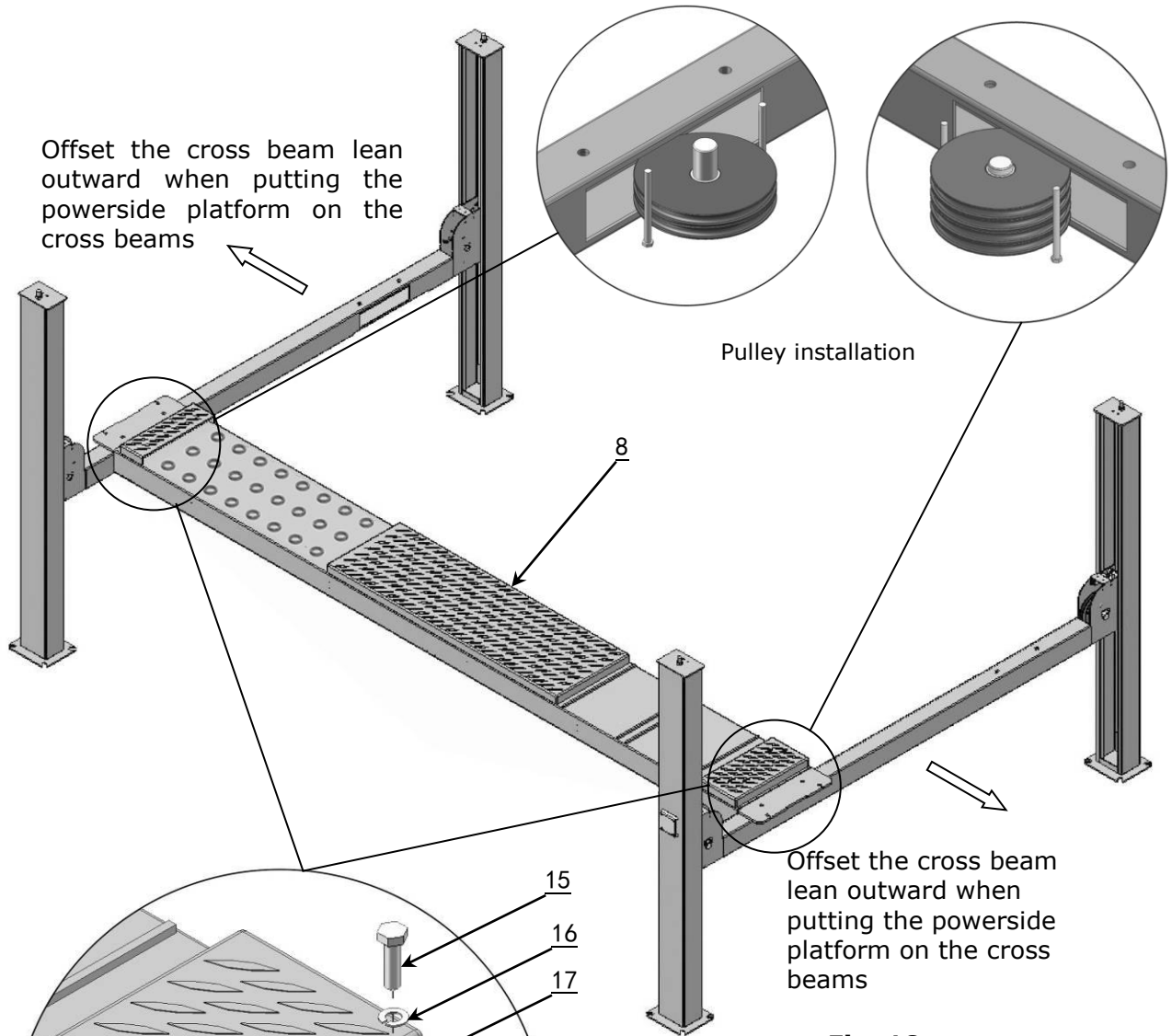
G. Put the cross beams at the same height (See Fig. 17).



**Fig. 17**

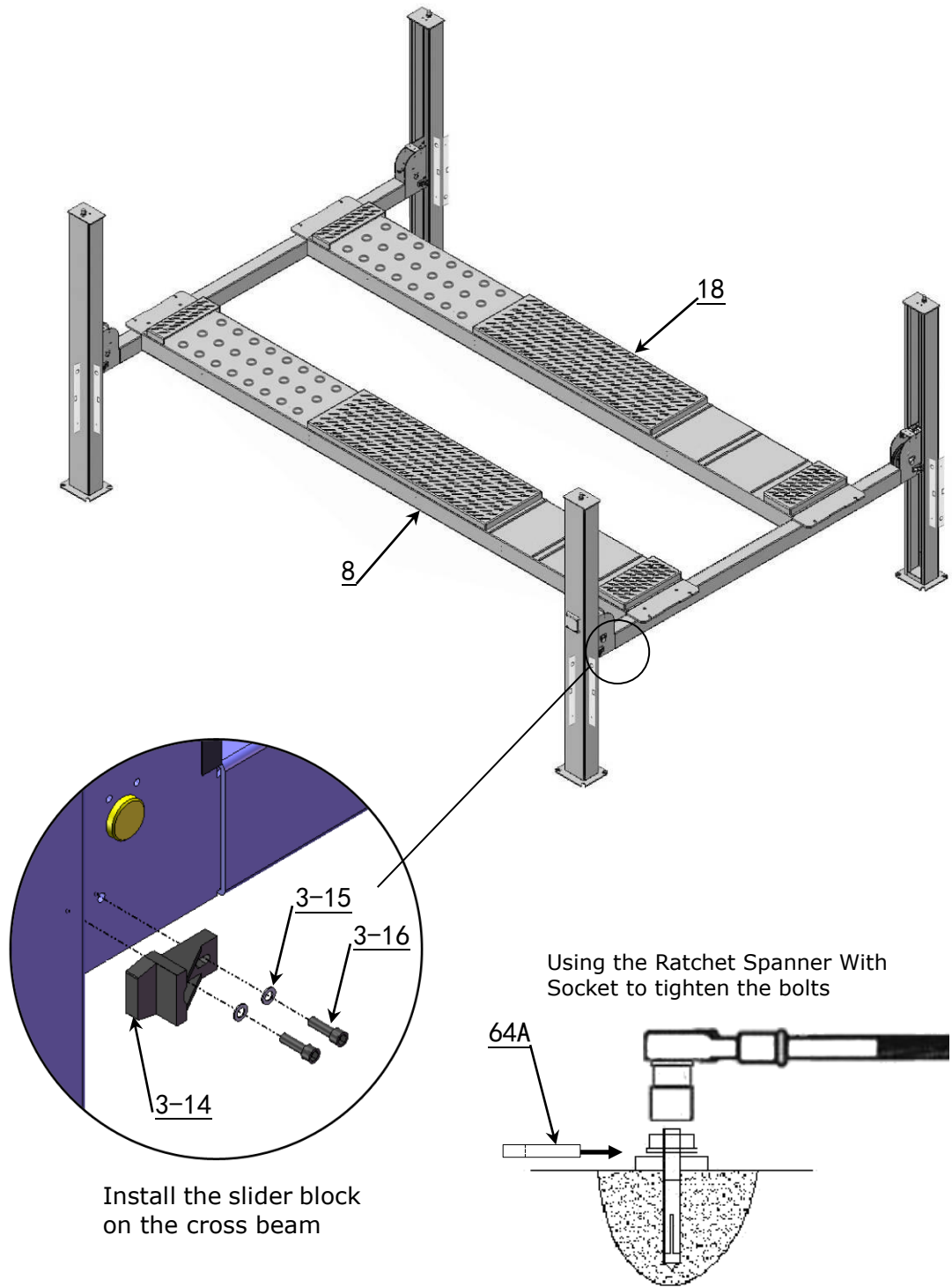
## H. Install powerside platform.

1. Put the powerside platform upon the cross beams by fork lift or manual, offset the cross beams to the outside till the pulleys of both platforms can set up into the cross beams (See Fig.18), Install the powerside platform and screw up the bolts(See Fig.19).



Install the powerside platform and screw up the bolts

**I. Assembly offside platform and slider block, check the plumbness of columns with level, adjusting with the shims if not, and then tighten the anchor bolts (See Fig. 20).**

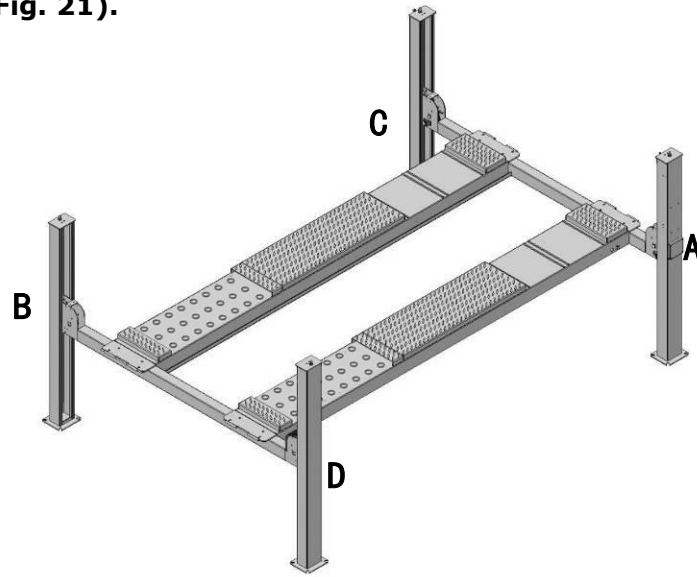


**Note: The tightening torque for the anchor bolt is 150N.m**

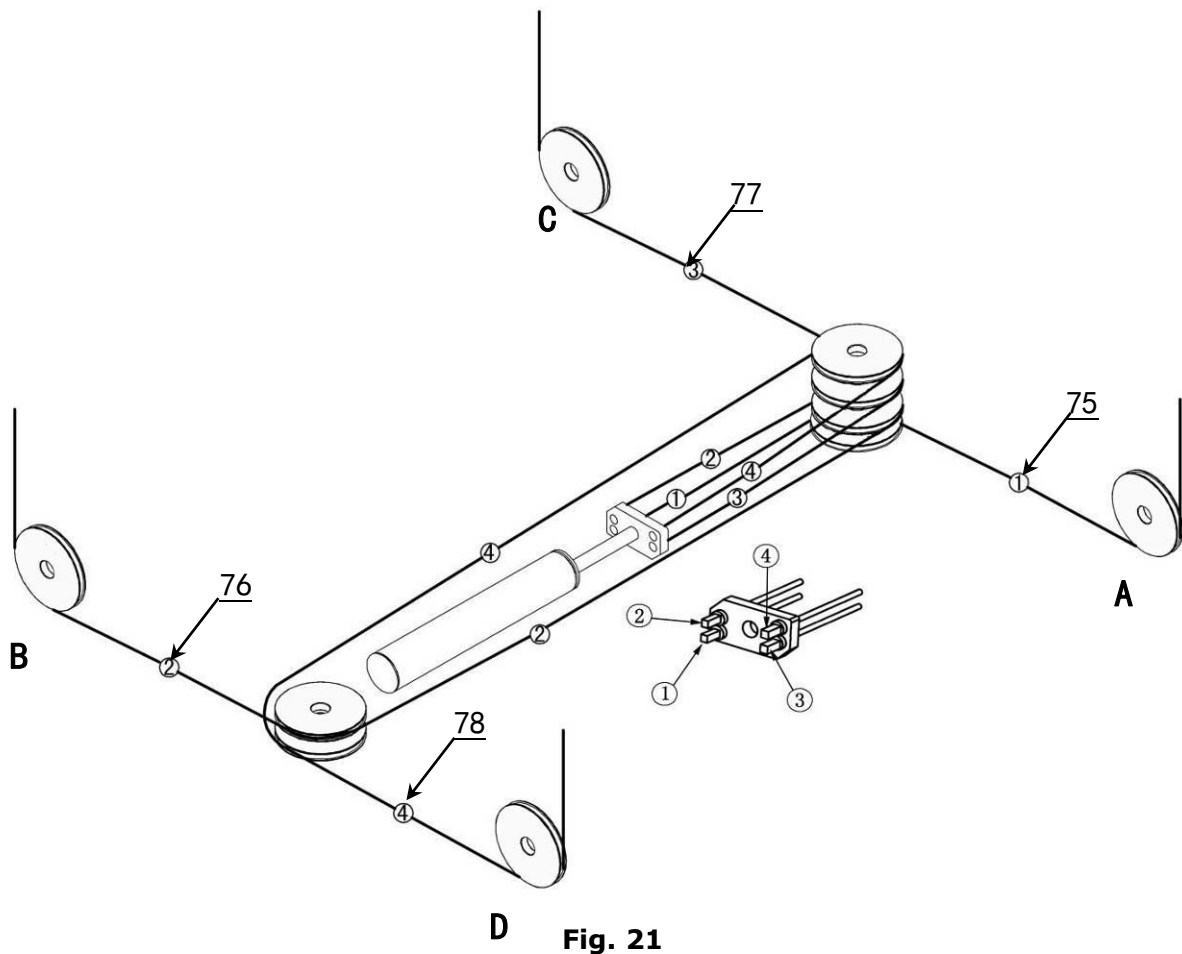
**Fig. 20**

## J. Illustration for cable installation

1. Pass through the cables from the platform to the columns according to the number of the cables (**See Fig. 21**).



NO.	1	2	3	4
Cable Length (inc. connecting fitting)	3250mm 128"	9260mm 364 1/2"	4850mm 191"	7654mm 301 3/8"



**Fig. 21**



2. The cable pass through the cross beam to top plate of columns and be screwed with cable nuts. Installation for Cable limit Pin on cross beam (See Fig. 22).

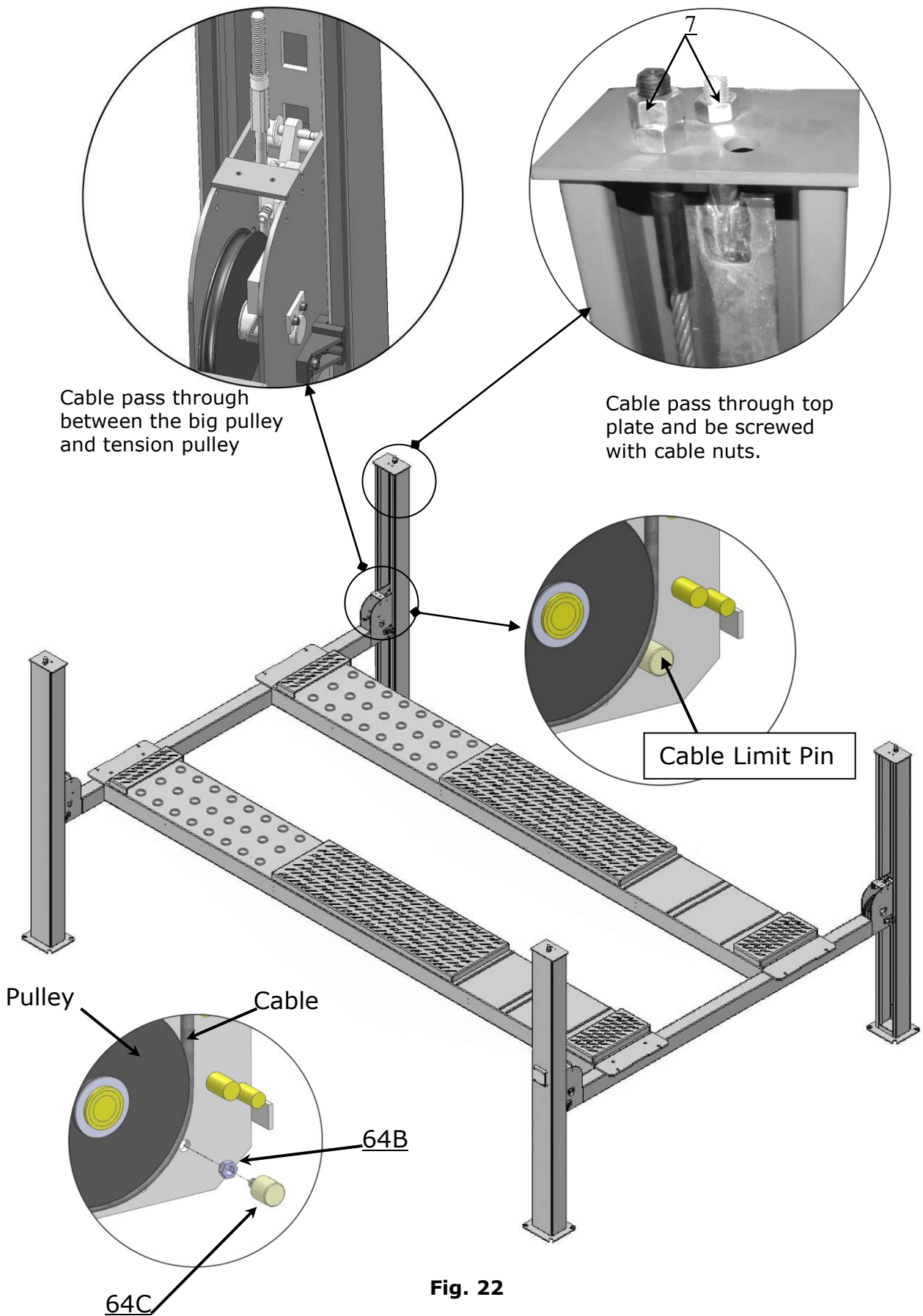
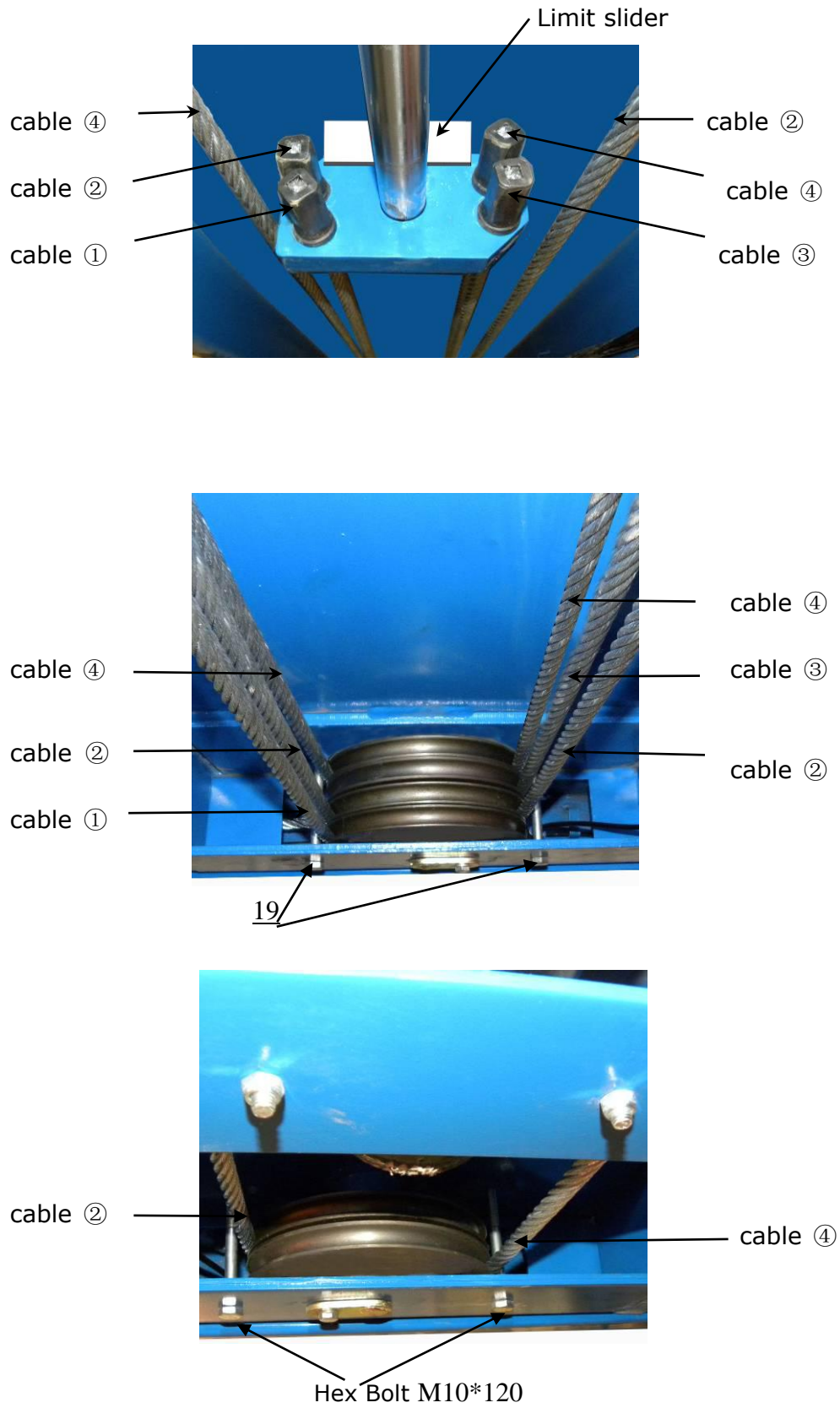


Fig. 22

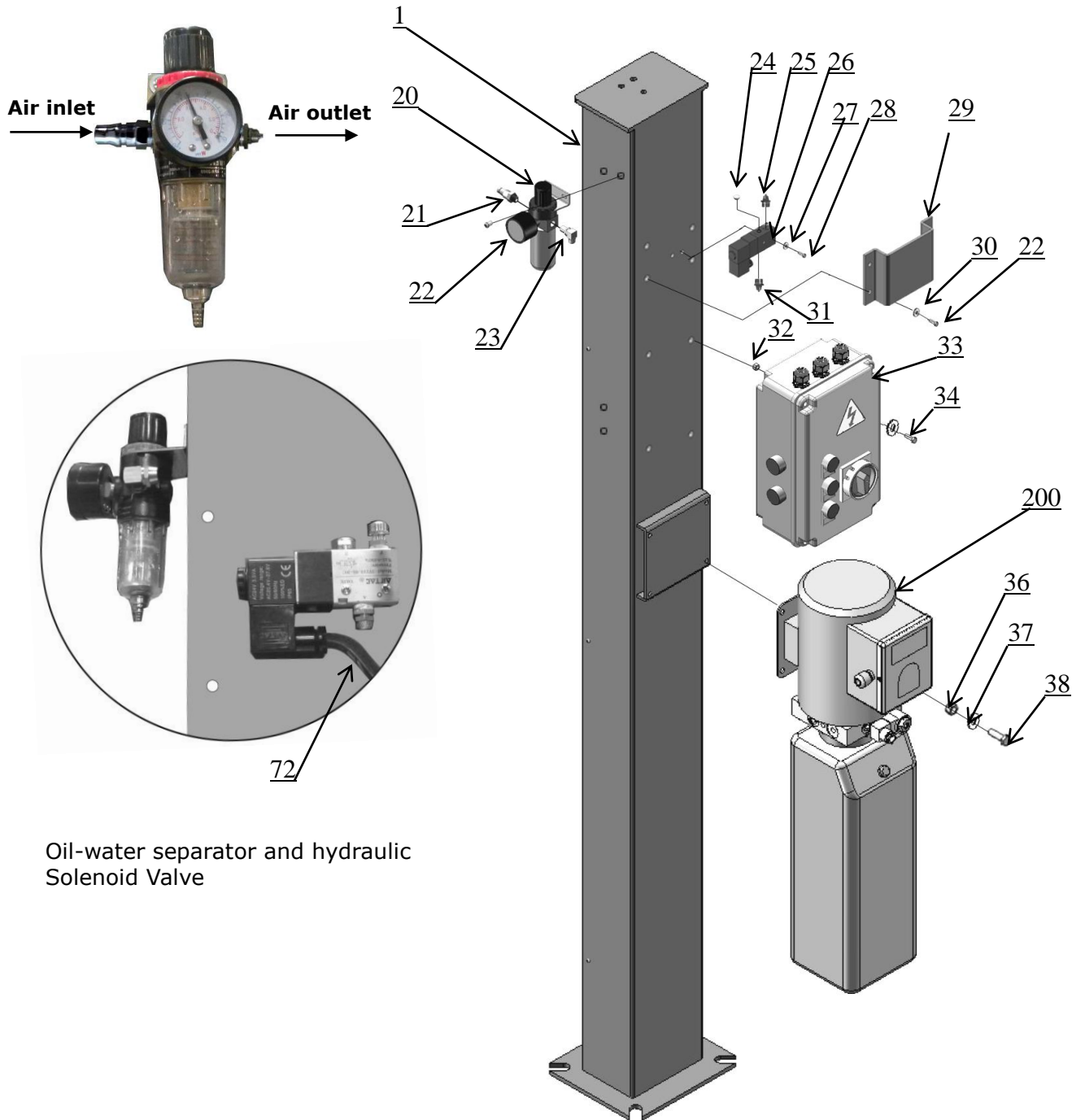
3. Illustration for platform cables (See Fig. 23).



**Fig. 23**

## K. Install oil-water separator, hydraulic solenoid valve, control box and power unit

1. For Electric control air-operated four post lift (See Fig. 24).

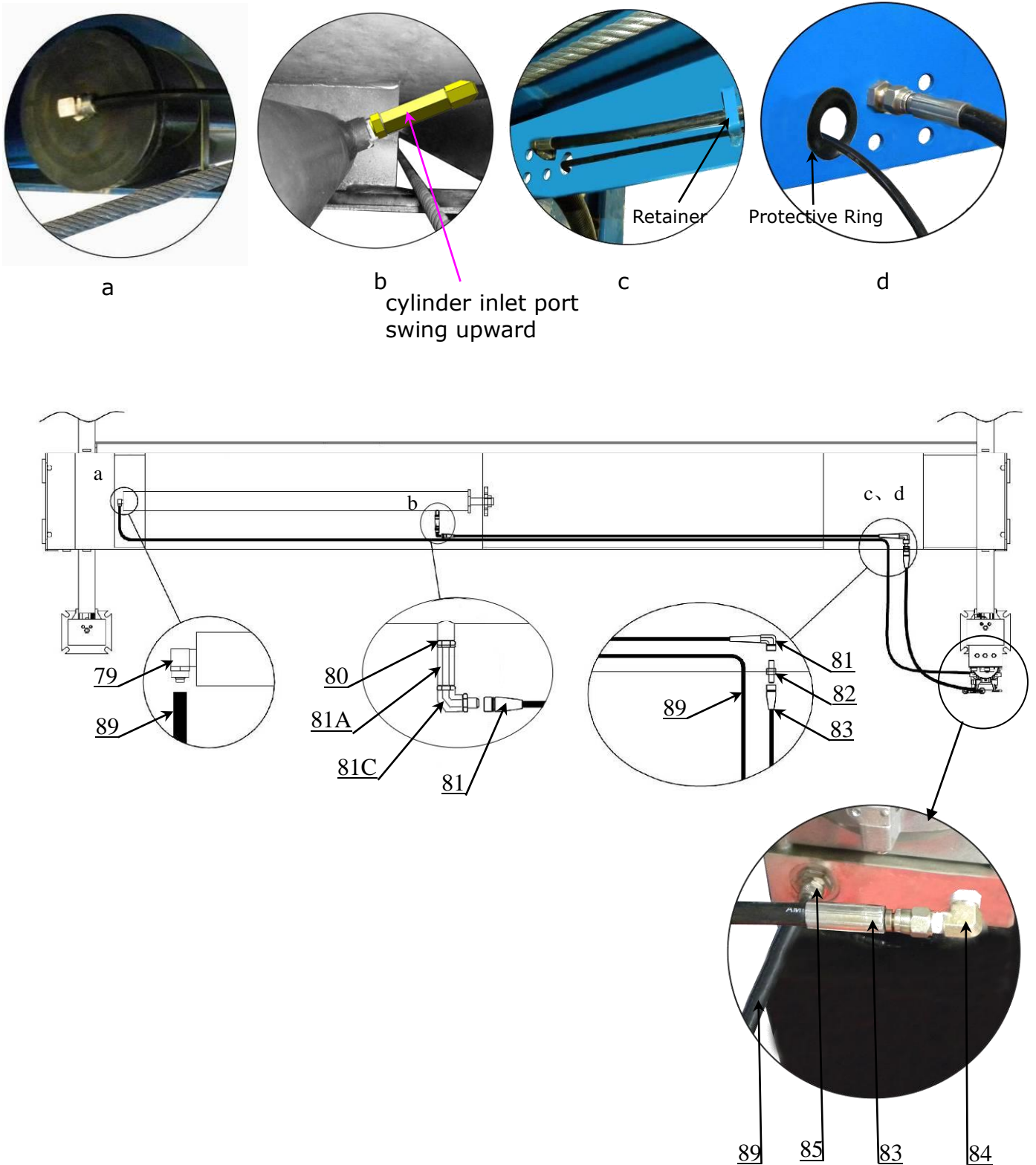


Oil-water separator and hydraulic Solenoid Valve

Fig. 24

**L. Install hydraulic system (See Fig. 25).**

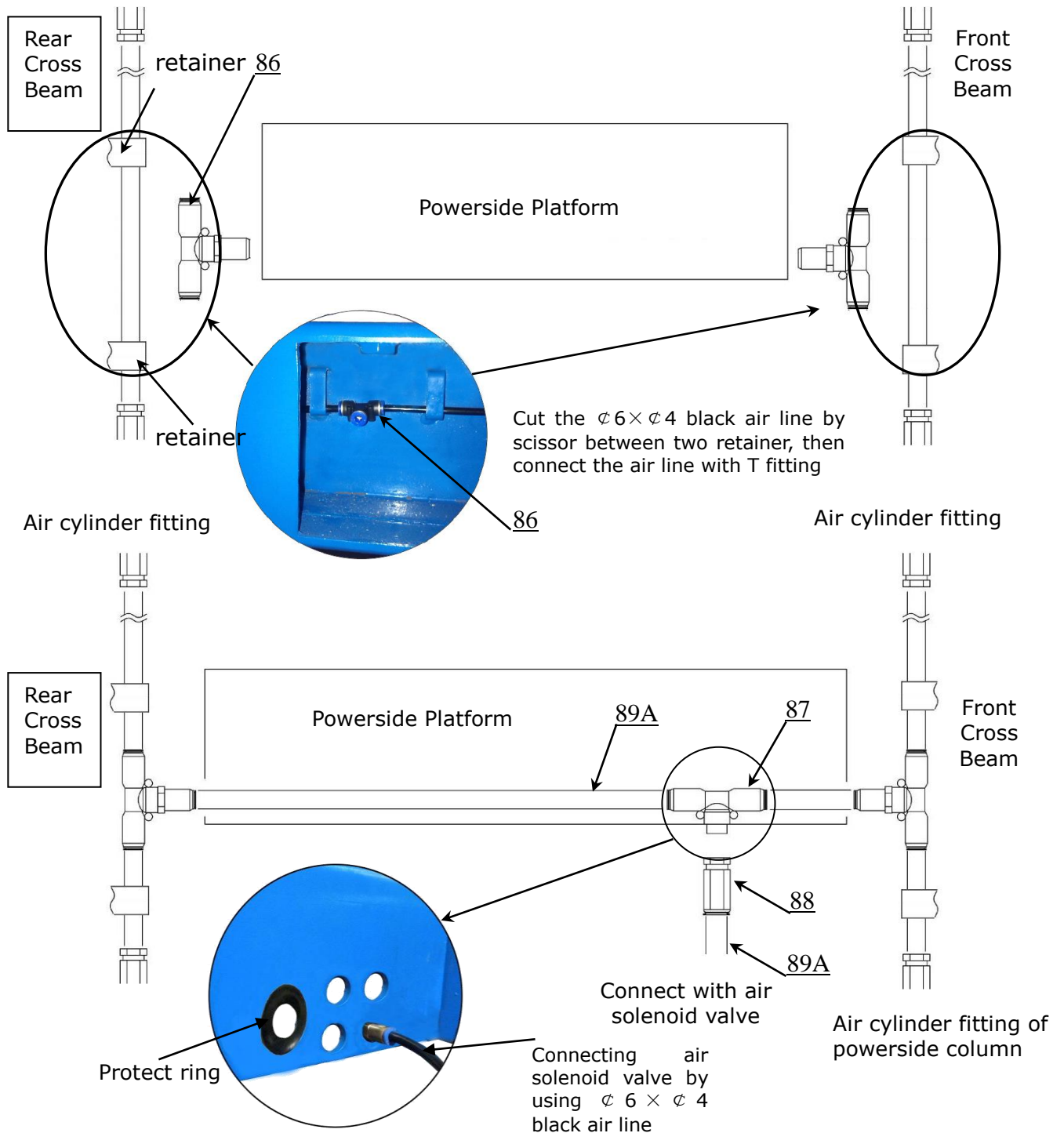
**Note:** Oil hoses and oil return pipe connected to oil cylinder must be passed above the cable and cylinder inlet port must swing upward to avoid the oil hose and oil return pipe scratched by cable.



**Fig. 25**

### M. Install air-line system

1. Cut the  $\phi 6 \times \phi 4$  black air line by scissor between two retainer, then connect the air line with T fitting. (See Fig. 26).
2. Connecting front and rear Cross Beam cylinders by using  $\phi 6 \times \phi 4$  black air line (See Fig. 27).
3. Connecting air solenoid valve by using  $\phi 6 \times \phi 4$  black air line (See Fig. 27).



**Fig. 27**



3. Connecting oil-water separator and air solenoid valve using air line (See Fig. 28).

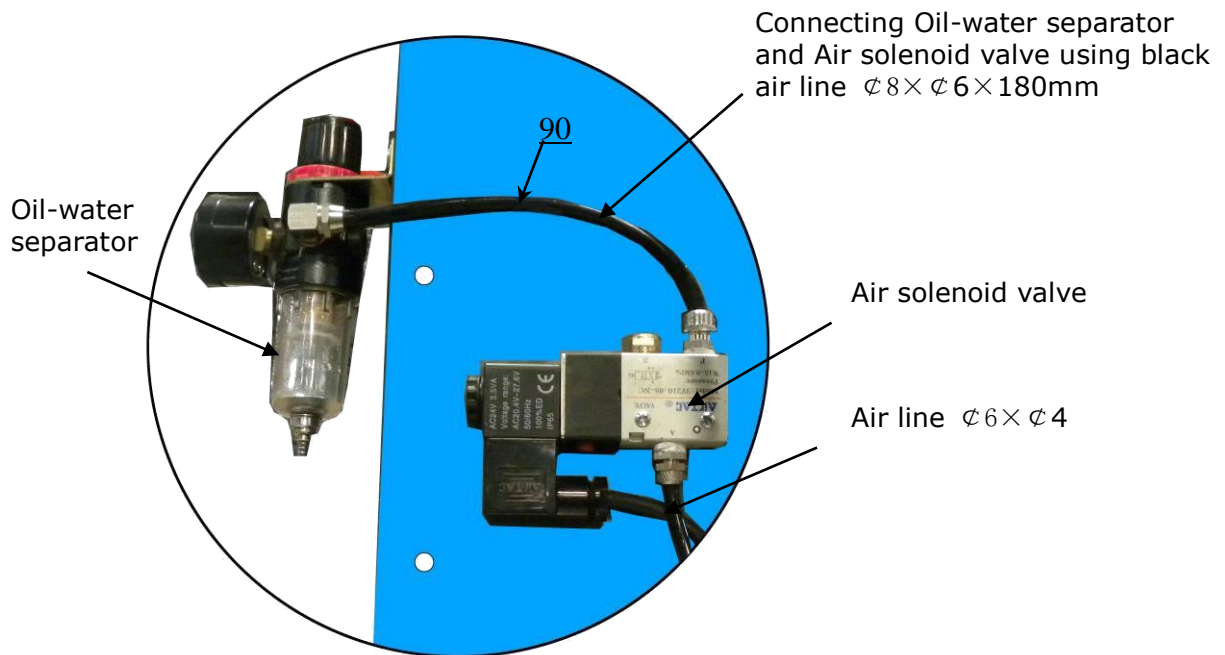


Fig. 28

4. Connecting air inlet (air supply pressure  $5\text{kg/cm}^2 - 8\text{kg/cm}^2$ ), adjusting the air pressure of oil-water separator to  $0.4 - 0.6\text{MPa}$  (See Fig. 29).

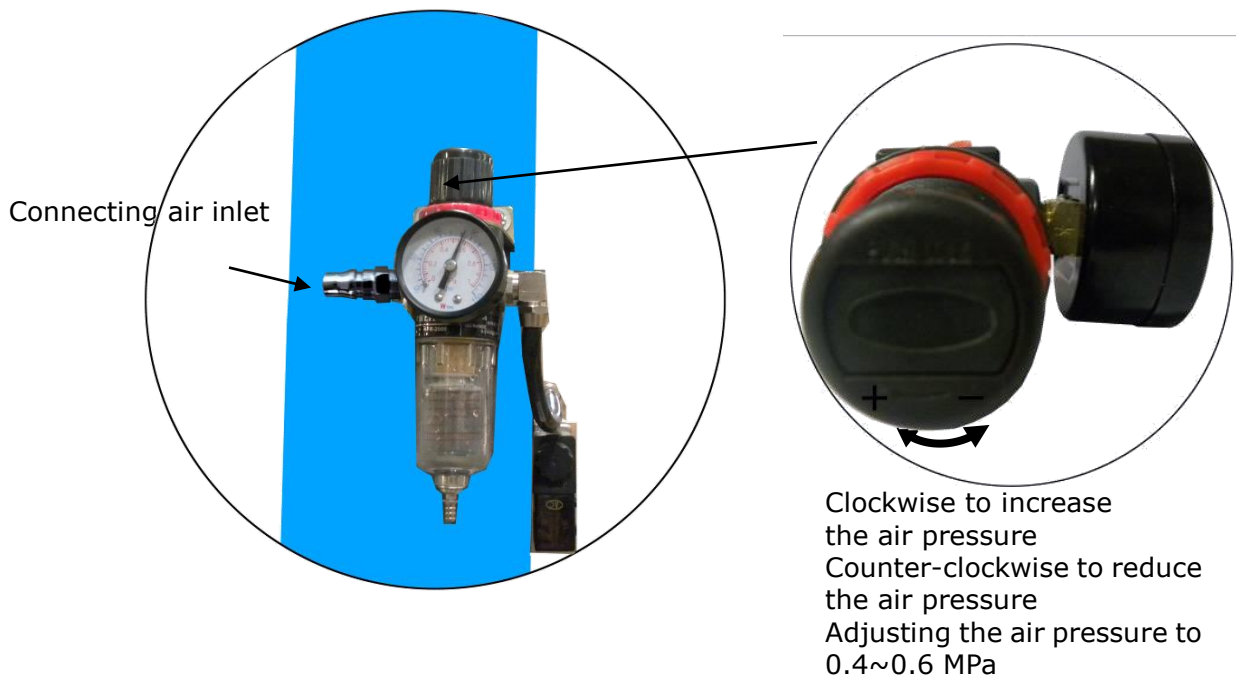
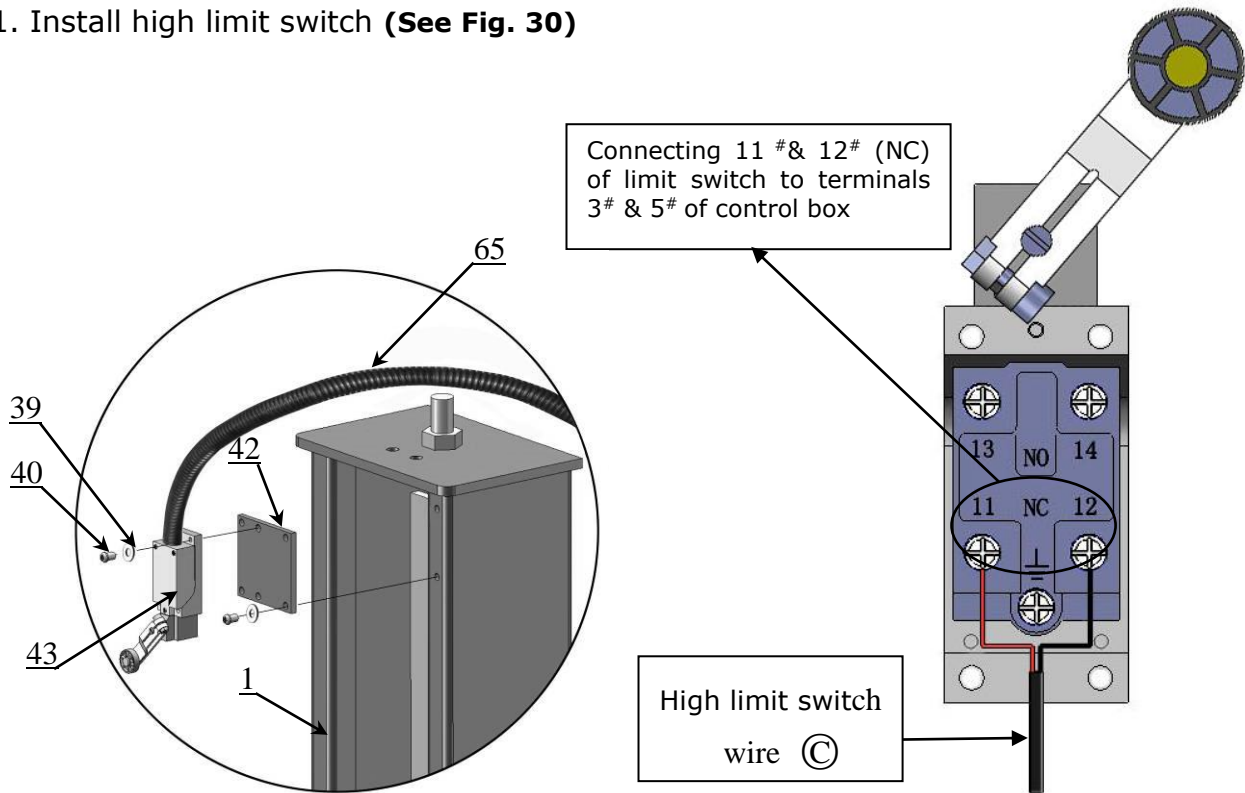


Fig. 29



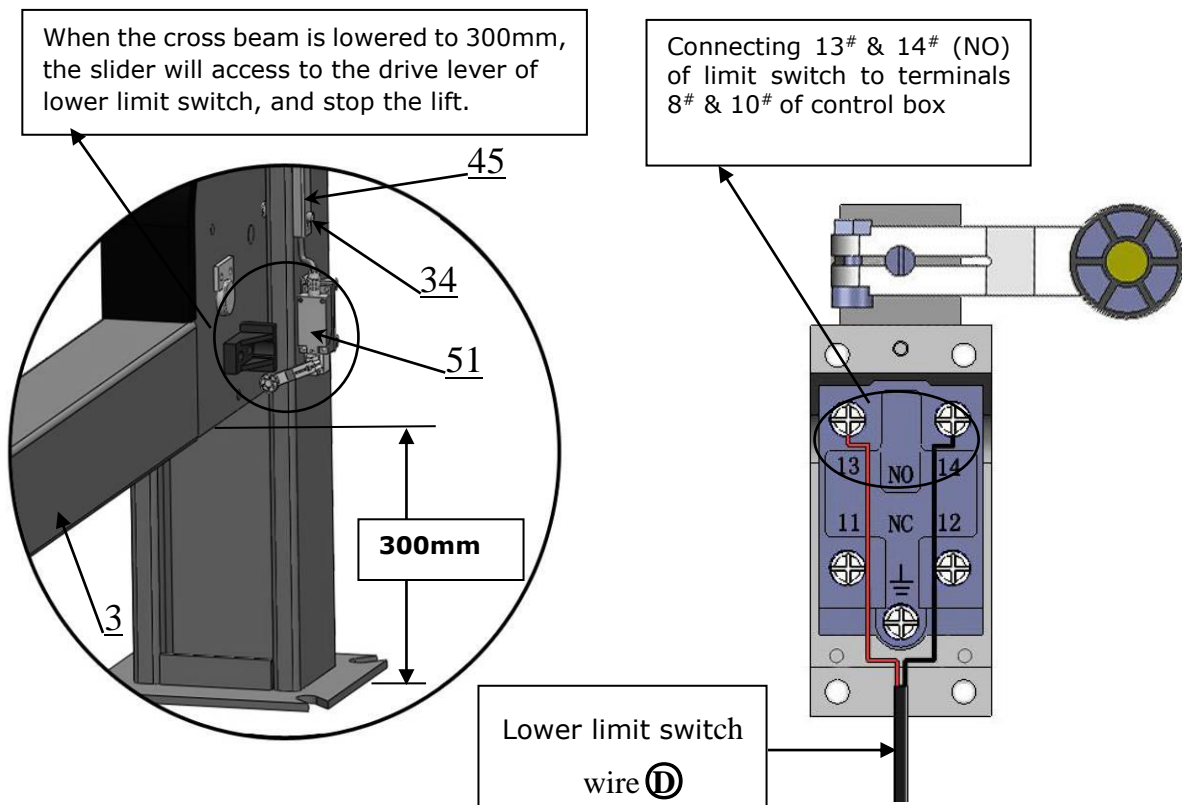
## N. Install electrical system

### 1. Install high limit switch (See Fig. 30)



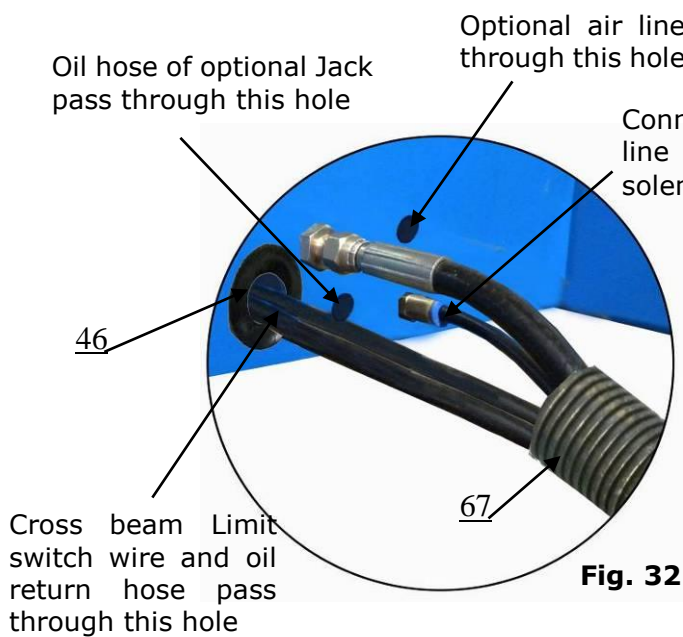
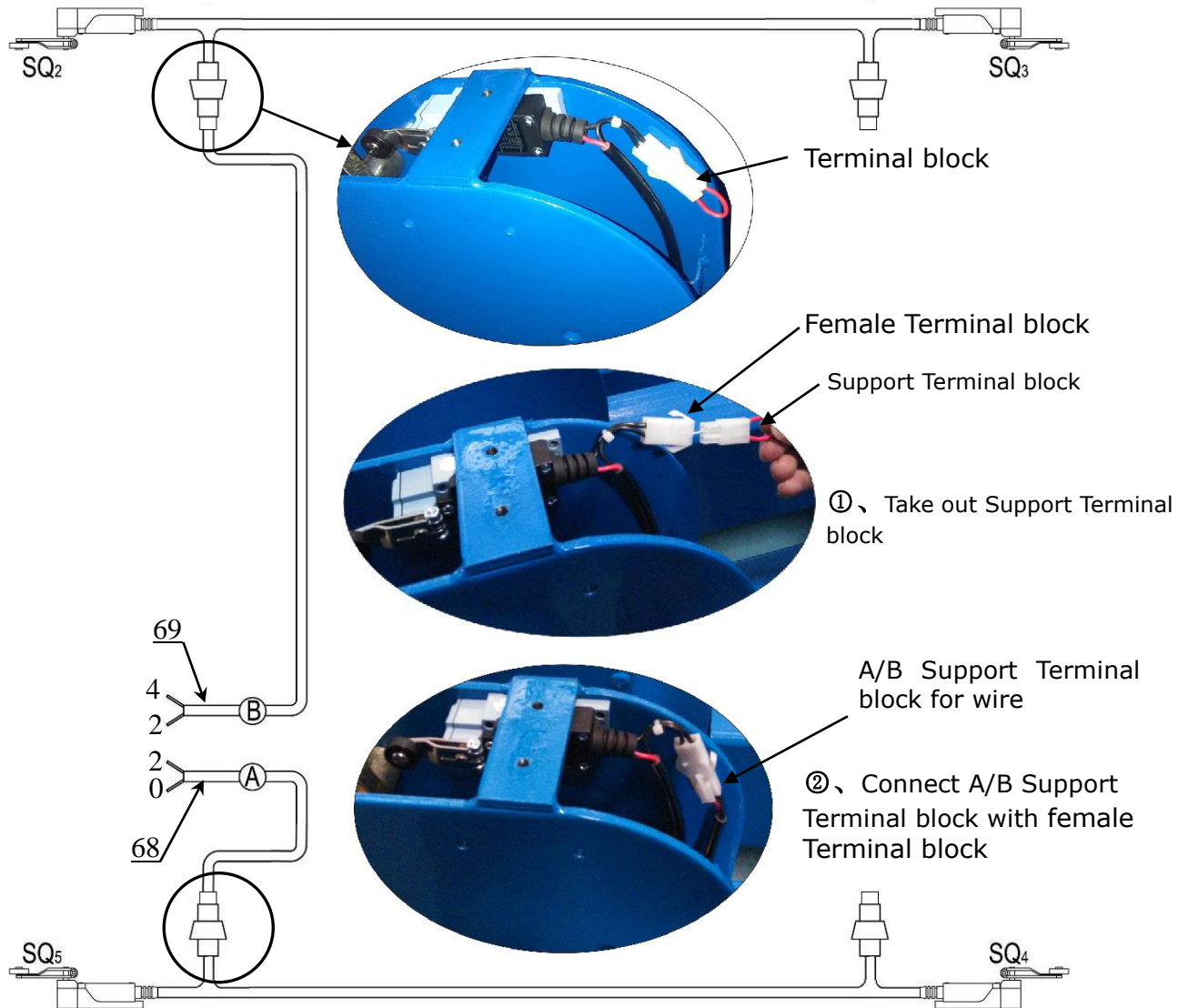
**Fig. 30**

### 2. Install lower alarm limit switch (See Fig. 31)

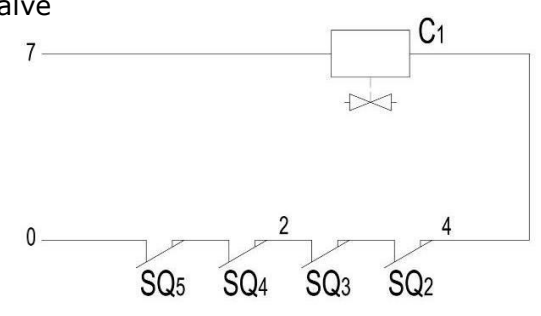


**Fig. 31**

3. Connecting wire of limit switch on cross beam to control box (See Fig. 32).



**Fig. 32**



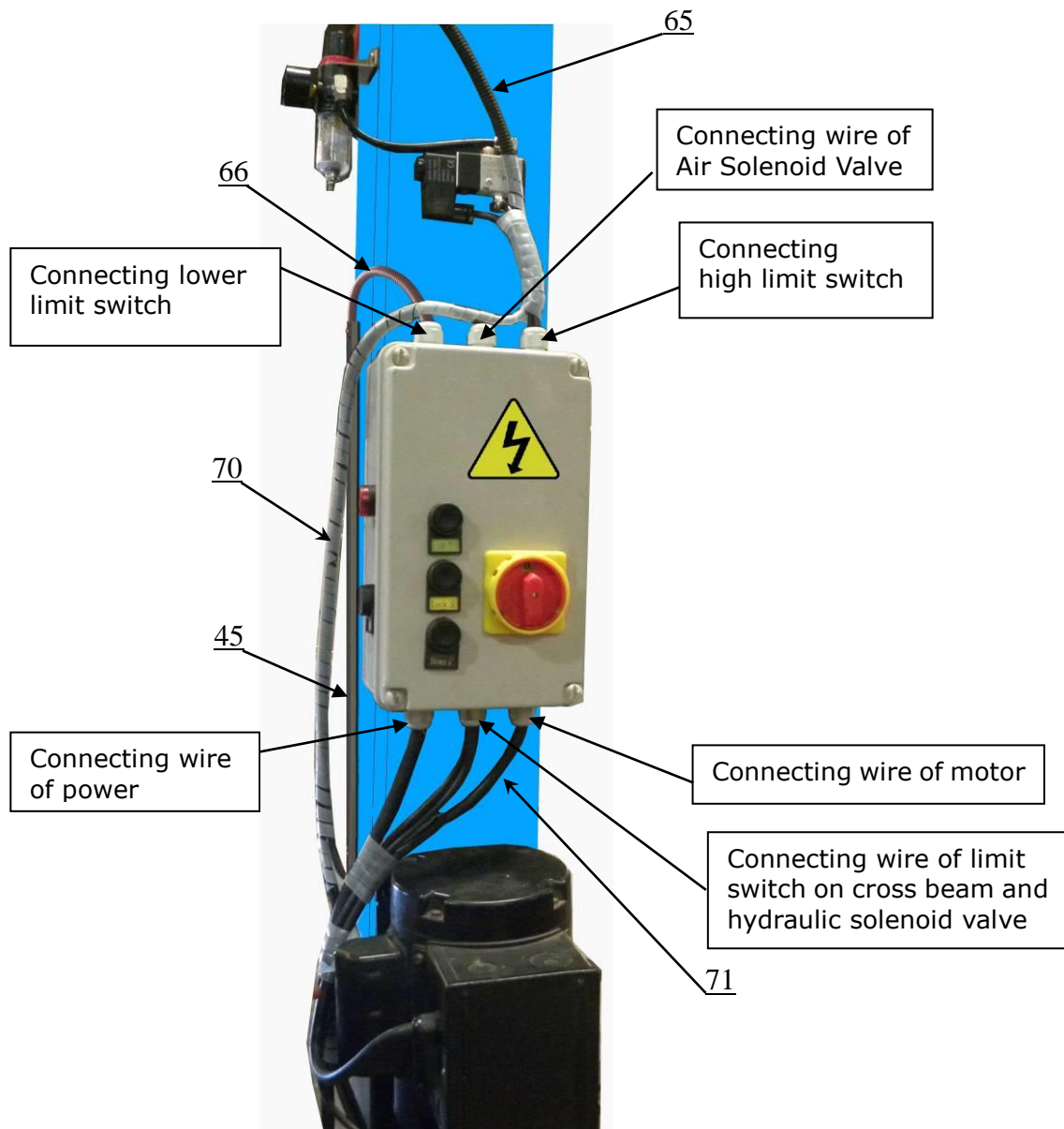
Schematic circuit diagram for Cross beam limit switch wire

4. Connecting wire with control box (See Fig. 33).

**Note: 1) Specification of wire of limit switch and Air solenoid valve is  $2 \times 1^2$  (two wires cable, wire size  $1 \text{ mm}^2$ )**

**2) Wire cable for power source and motor are  $4 \times 2.5^2$  (Four wires cable, wire size  $2.5 \text{ mm}^2$ )**

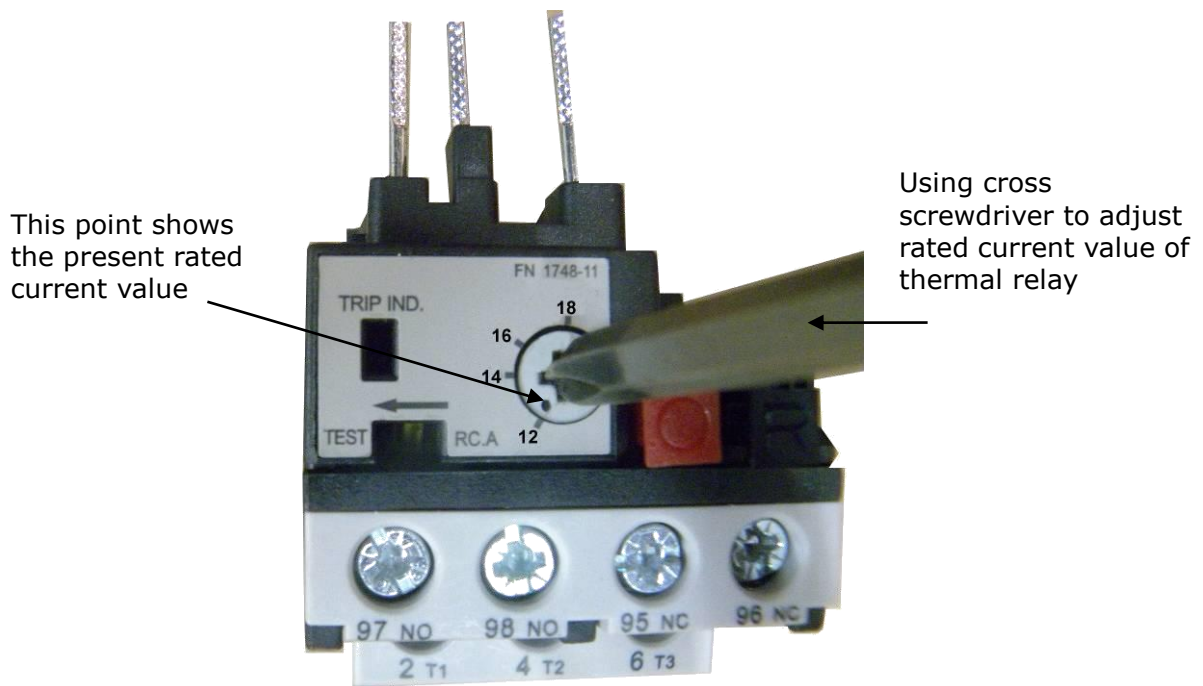
**3) Using white bobbin to wind around wire and air line.**



**Fig. 33**

5. Adjusting the current rating of thermal relay in control box according to the different configurations of hydraulic power unit. In general, the electric current of thermal relay should equal or larger than that of motor. The following table shows rated current regulation of thermal relay in case of different hydraulic power unit.

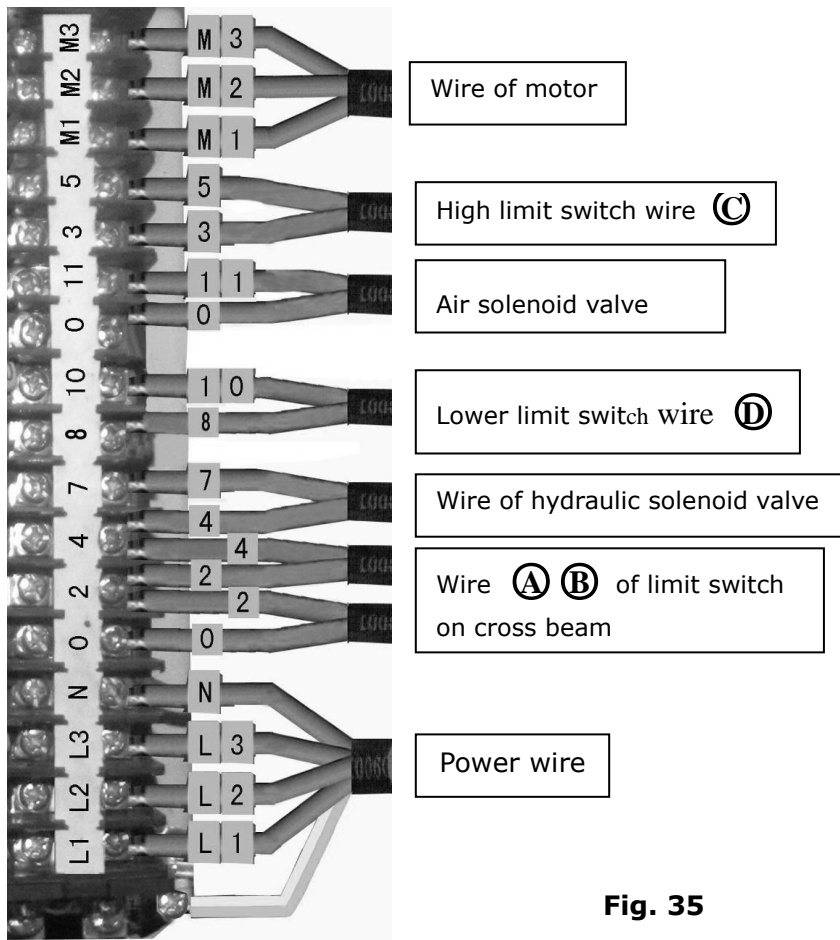
Hydraulic power unit	INDYPRO					SPX		Monarch		
	220V 3HP	380V 3HP	415V 3HP	220V 4HP	380V 4HP	220V 3HP	380V 3HP	220V 3HP	380V 3HP	415V 3HP
Rated current of thermal relay	16A	12A	12A	22A	14A	18A	12A	16A	12A	12A



**Fig. 34**

## 6. 380V Wire connection and circuit diagram

### 6.1 Wire connection diagram in the control box (See Fig. 35).

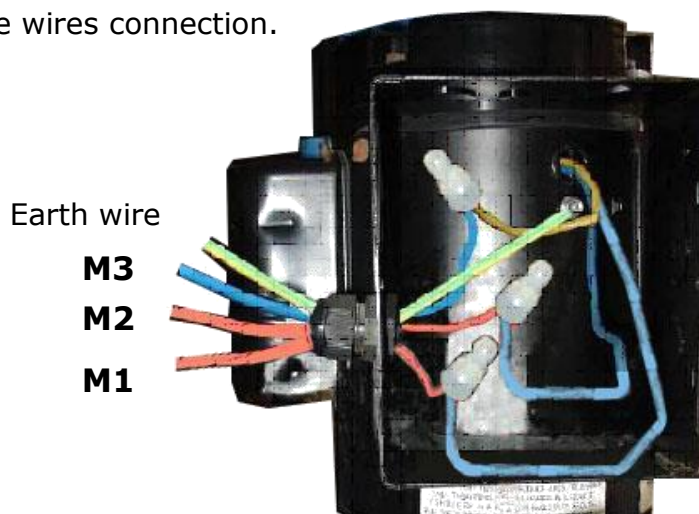


**Fig. 35**

### 6.2 380V Wire connection diagram of hydraulic motor (See Fig. 36).

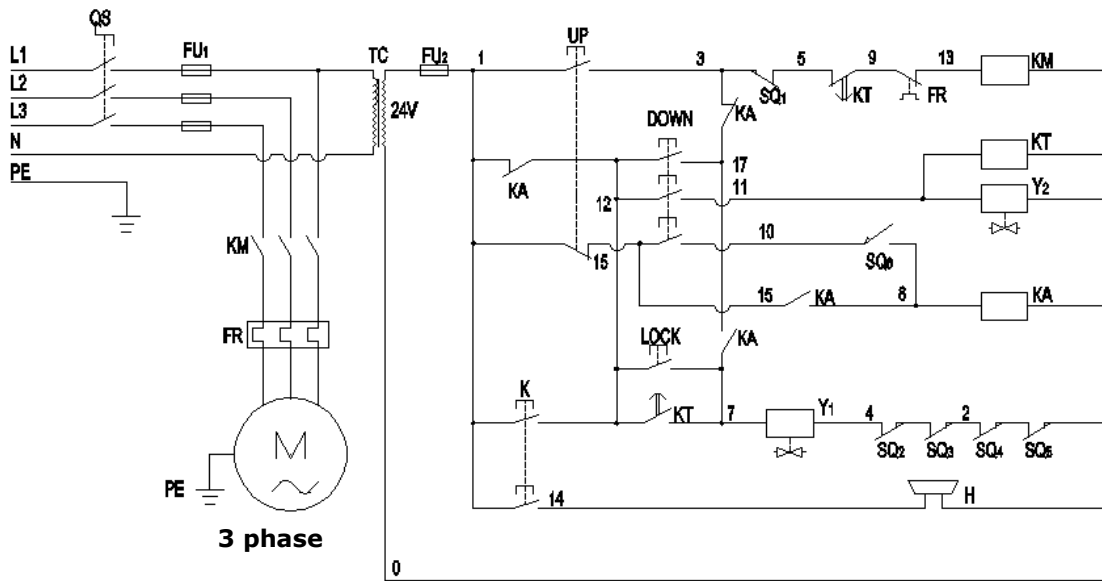
Motor wire (M1、M2、M3) are connected to the three wires in the motor.

Turn on the power, push button "UP", if motor run but lift is not worked, pls. change the wires connection.



**Fig. 36**

### 6.3 380V Circuit diagram (See Fig. 37).



**Fig. 37**

Circuit component

Item	Name	Code	Specification	Item	Name	Code	Specification
1	Power switch	QS	380V AC	10	Push button	Down	triplex
2	Fuse	FU <sub>1</sub>	25A			K	duplex
3	Fuse	FU <sub>2</sub>	3A	11	Push button	LOCK	single
4	AC contactor	KM	24V AC	12	Motor	M	3 phase
5	Time relay	KT	24V AC	13	Transformer	TC	24V AC
6	Limit switch	SQ <sub>(1~6)</sub>	10A	14	Thermal relay	FR	12A~18A
7	Air solenoid valve	Y2	24V AC	15	Auxiliary relay	KA	24V AC
8	Hydraulic solenoid valve	Y1	24V AC	16	Alarm	H	24V AC
9	Push button	UP	duplex				



7. 220V Wire connection and circuit diagram

7.1 Wire Connection diagram in the control box (See Fig. 38).

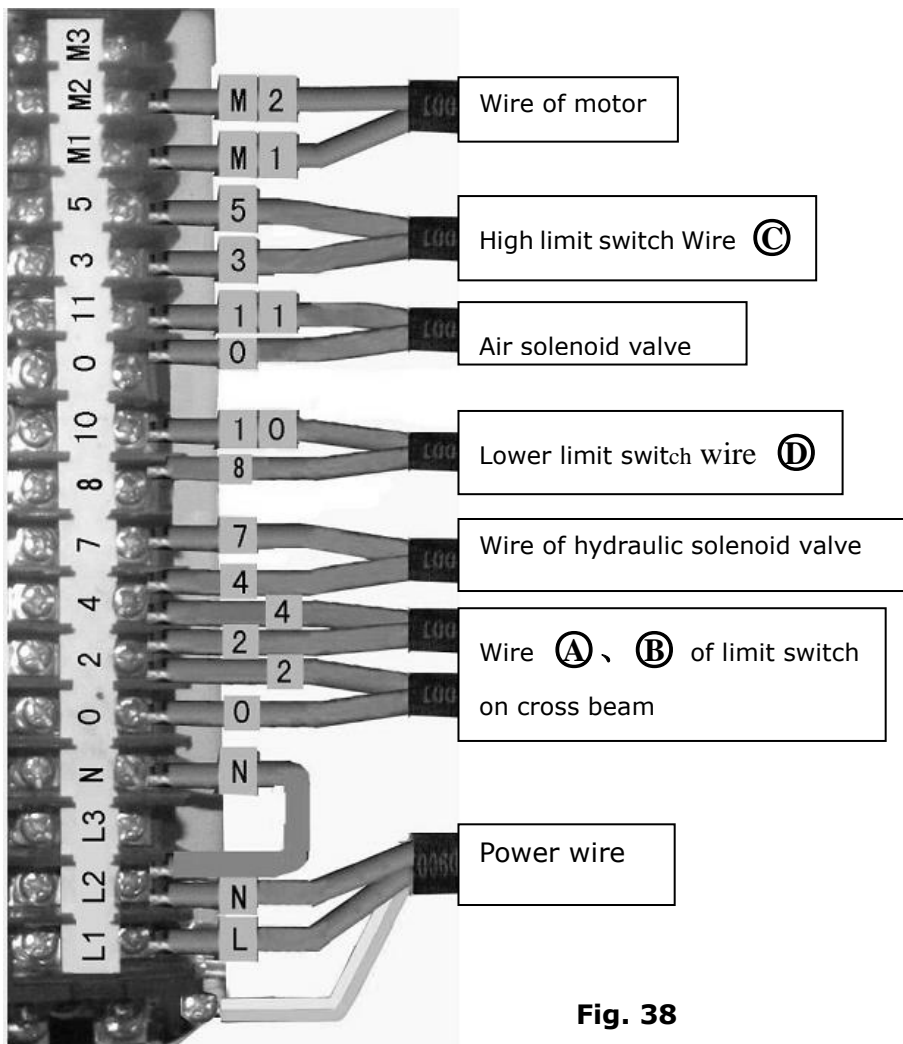


Fig. 38

7.2 220V Wire connection of hydraulic power unit (See Fig. 39).

Motor wire (M1、 M2) separately connected to two wires in the motor

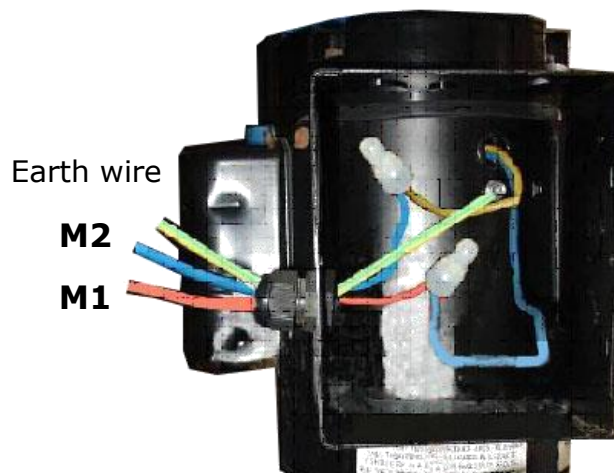


Fig. 39

7.3 220V Circuit diagram (See Fig. 40).

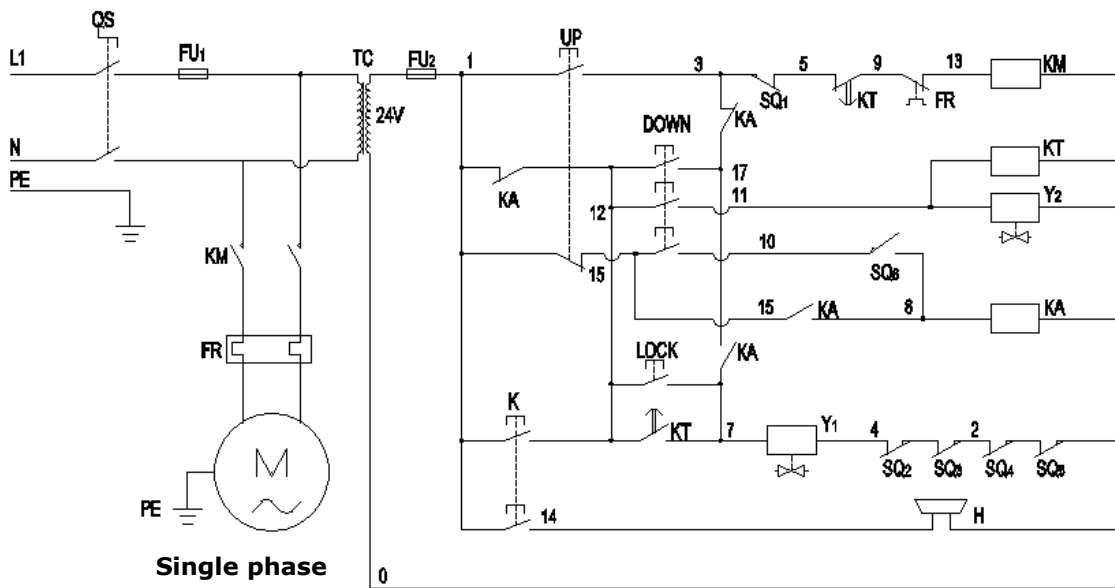


Fig. 40

Circuit component

Item	Name	Code	Specification	Item	Name	Code	Specification
1	Power switch	QS	380V AC	10	Push button	Down	triplex
2	Fuse	FU <sub>1</sub>	25A			K	duplex
3	Fuse	FU <sub>2</sub>	3A	11	Push button	LOCK	single
4	AC contactor	KM	24V AC	12	Motor	M	Single phase
5	Time relay	KT	24V AC	13	Transformer	TC	24V AC
6	Limit switch	SQ <sub>(1~6)</sub>	10A	14	Thermal relay	FR	12A~18A
7	Air solenoid valve	Y2	24V AC	15	Auxiliary relay	KA	24V AC
8	Hydraulic solenoid valve	Y1	24V AC	16	Alarm	H	24V AC
9	Push button	UP	duplex				

O. Install spring and safety cover of cross beam (See Fig. 41)

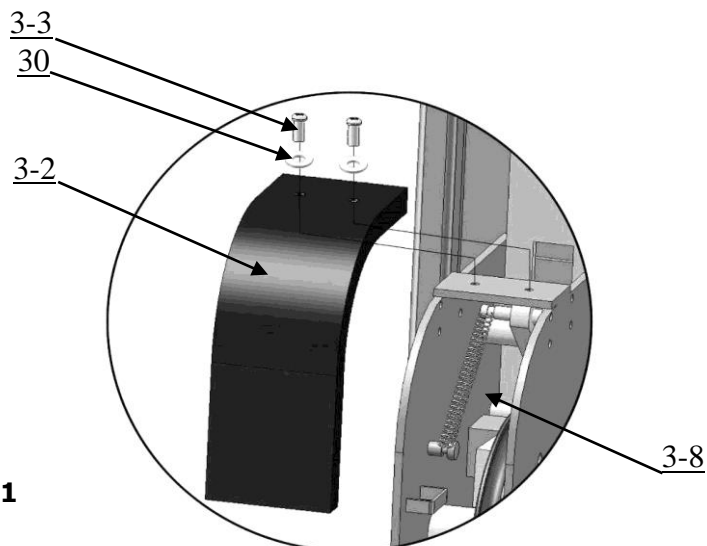
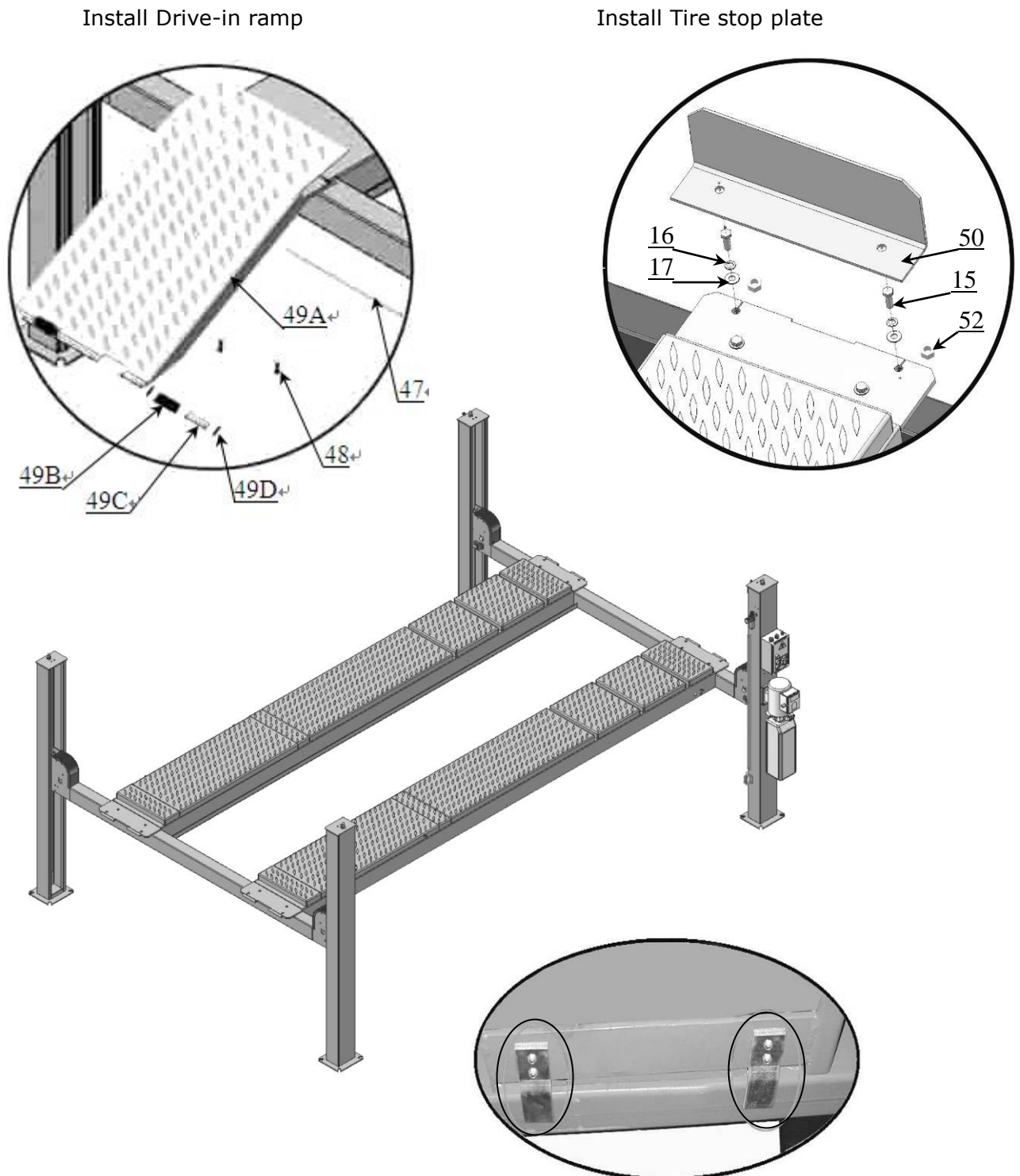


Fig. 41

**P. Install drive-in ramp, tire stop plate, platform lock plates, steel ball set (See Fig. 42)**



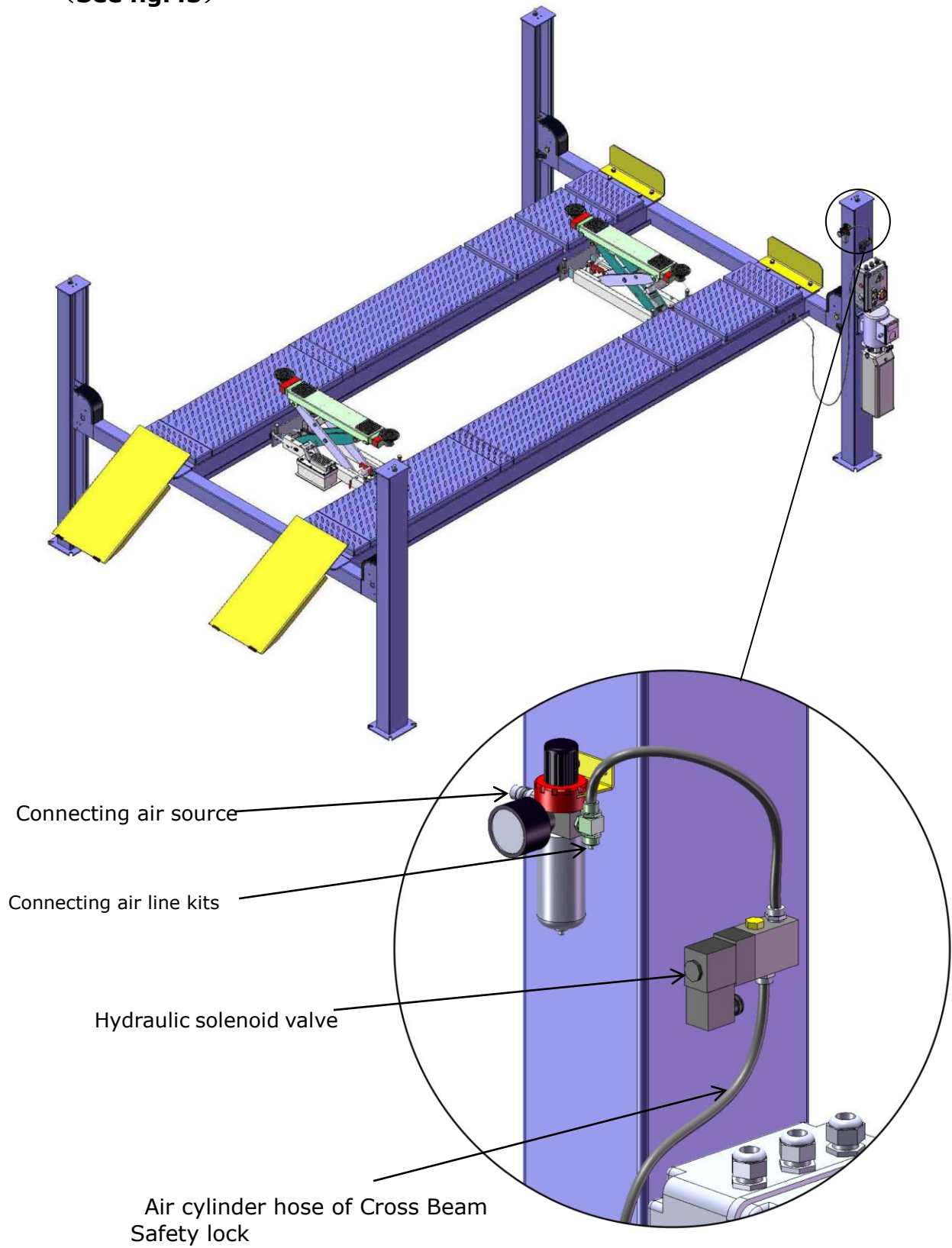
The lock plates are used to prevent the turning & slipping of offside platform, Using Hex bolt M8×20 for the connection.

**Fig. 42**

**Q Install optional Air line kits**

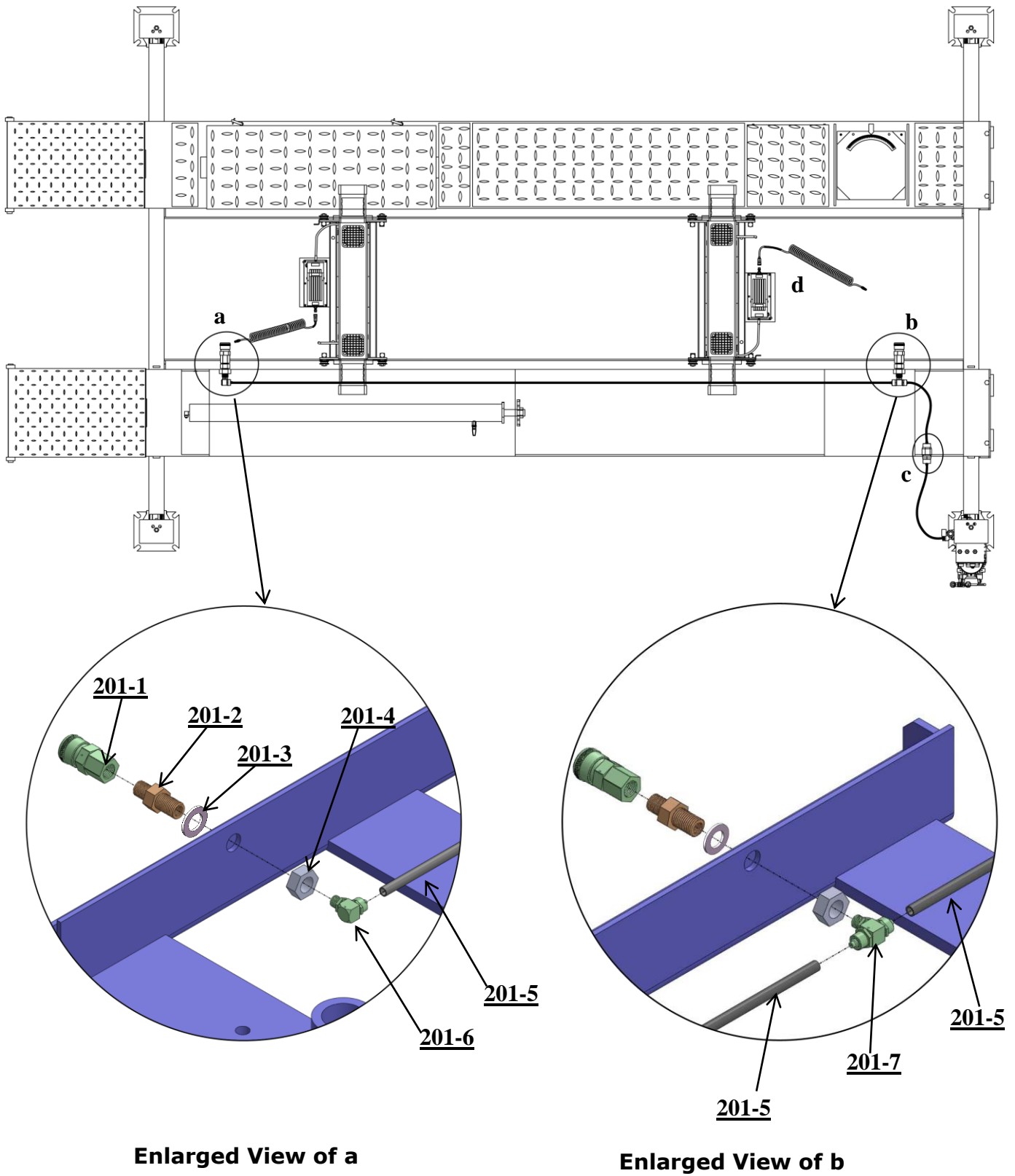
**1 Finish installation( include air line system and hydraulic system).**

**( See fig.43 )**

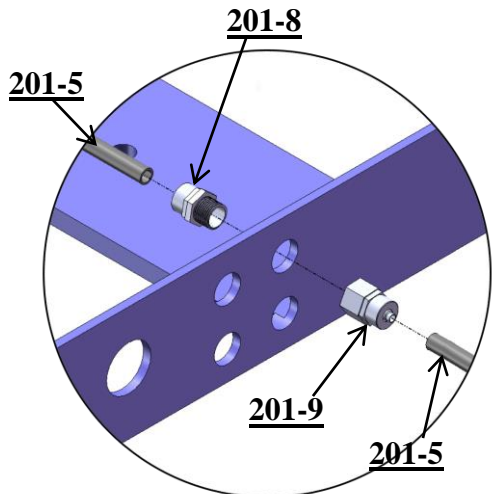


## 2. Install air line kits

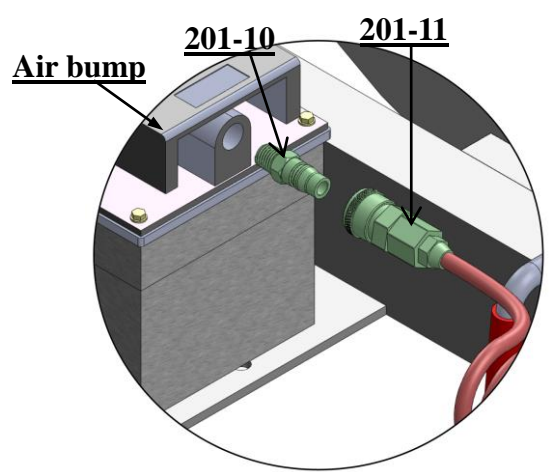
2.1 Install with black air hose  $\phi 8 * \phi 6$  (cut by installer) and connectors as Fig44.







**Enlarged View of c**

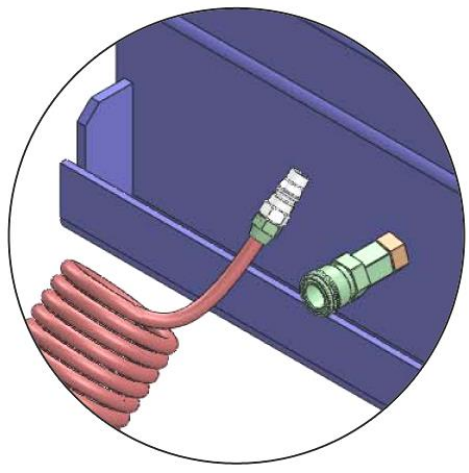


Spring air line is connected to the fitting of bump on Jack.

**Enlarged View of d**

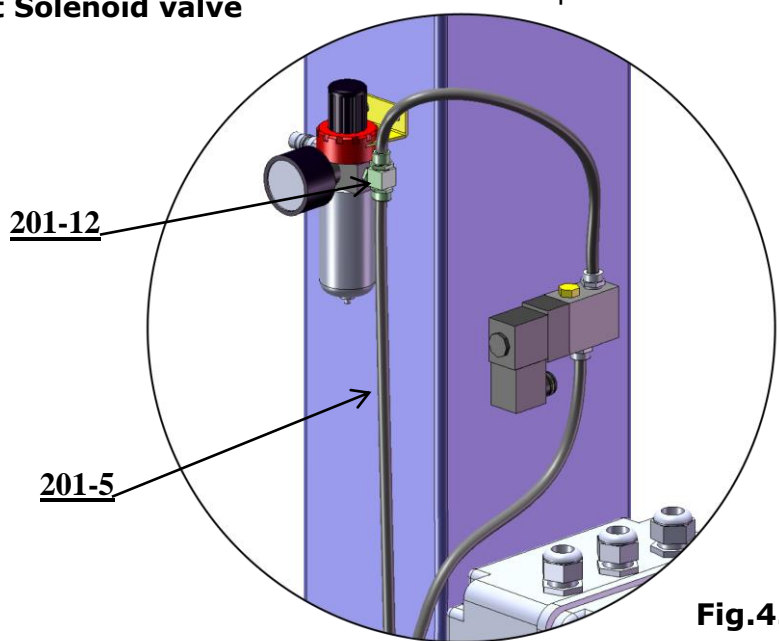


All the air hose and oil hose installed well as above manual are tied up and pass through Protecting plastic hose.



The another side of spring air line shown as d is connected to the fitting installed on platform.

**2.2 Connect Solenoid valve**



Air cylinder hose of crossbeam safety lock

**Fig.45**

**3. Connect air source, and handle Jack.**

# IV. EXPLODED VIEW

Model TFP09A

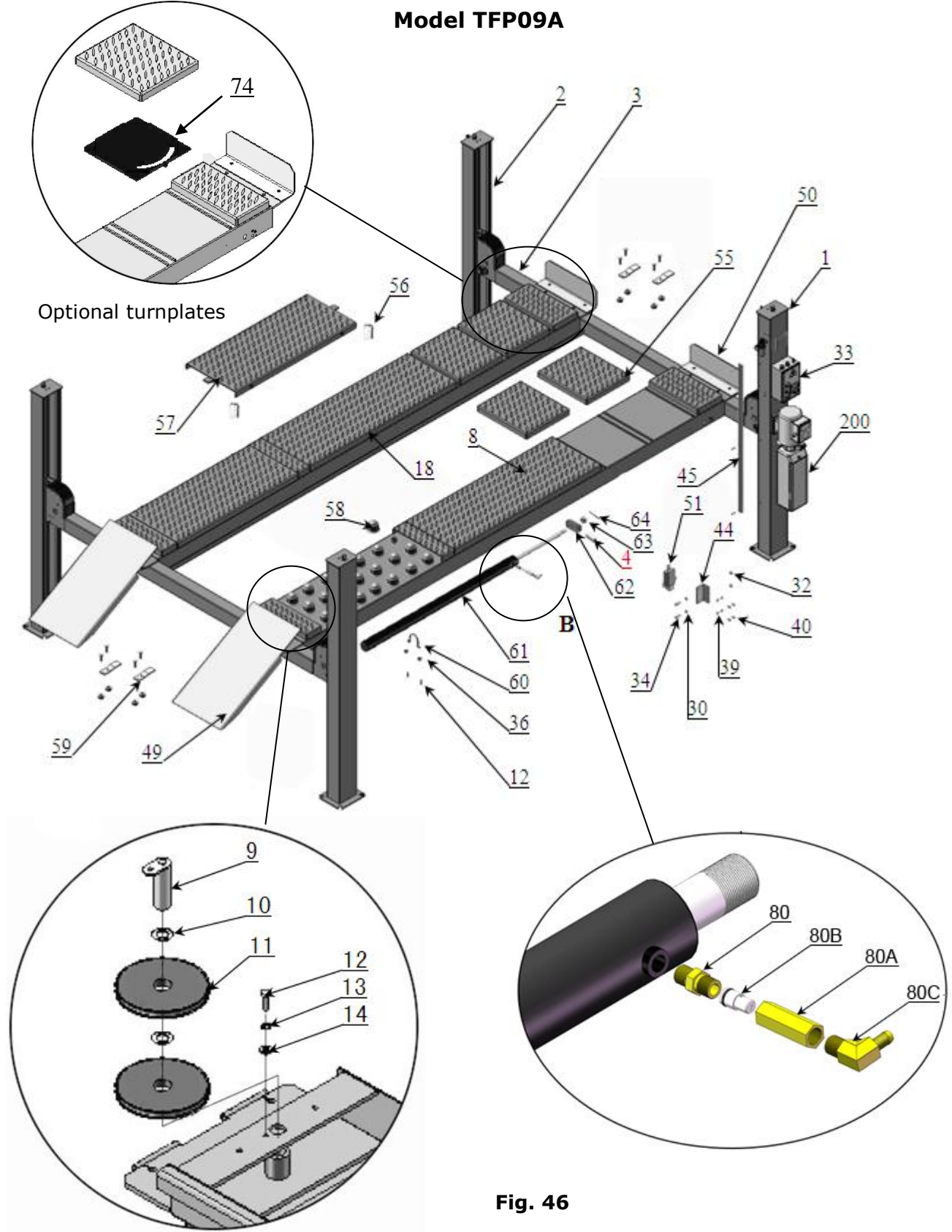


Fig. 46



## CROSS BEAM

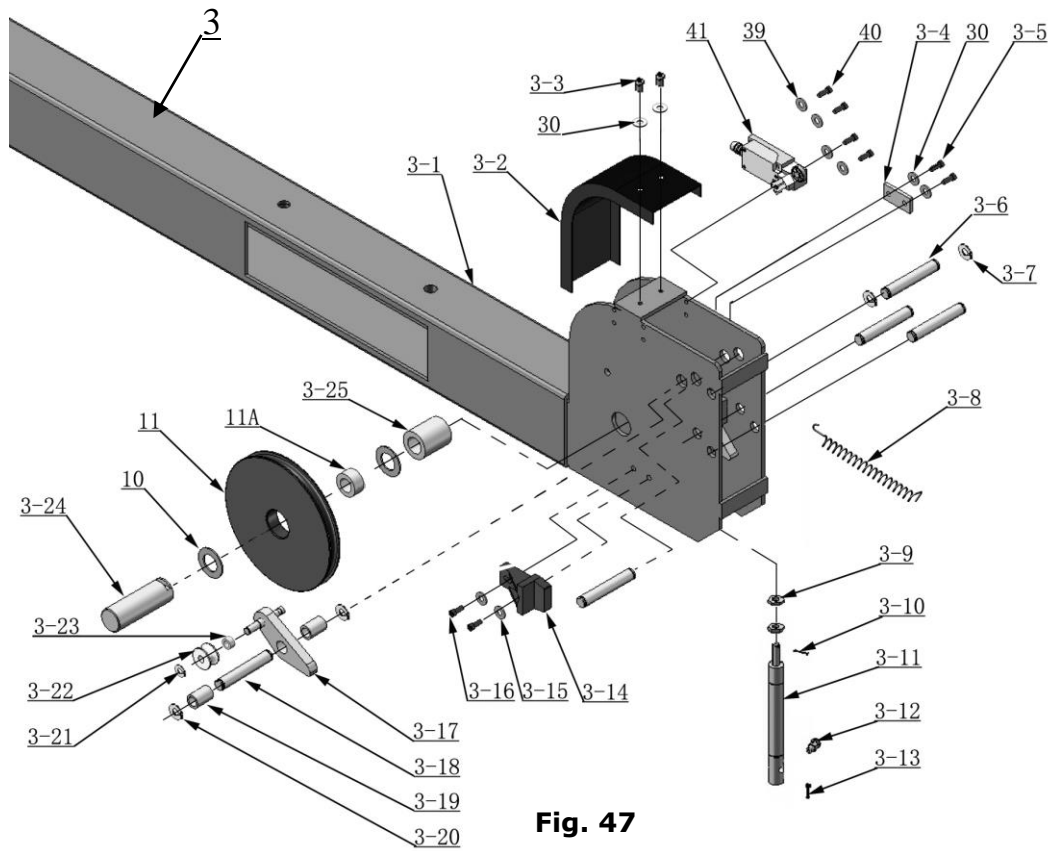


Fig. 47

## CYLINDERS

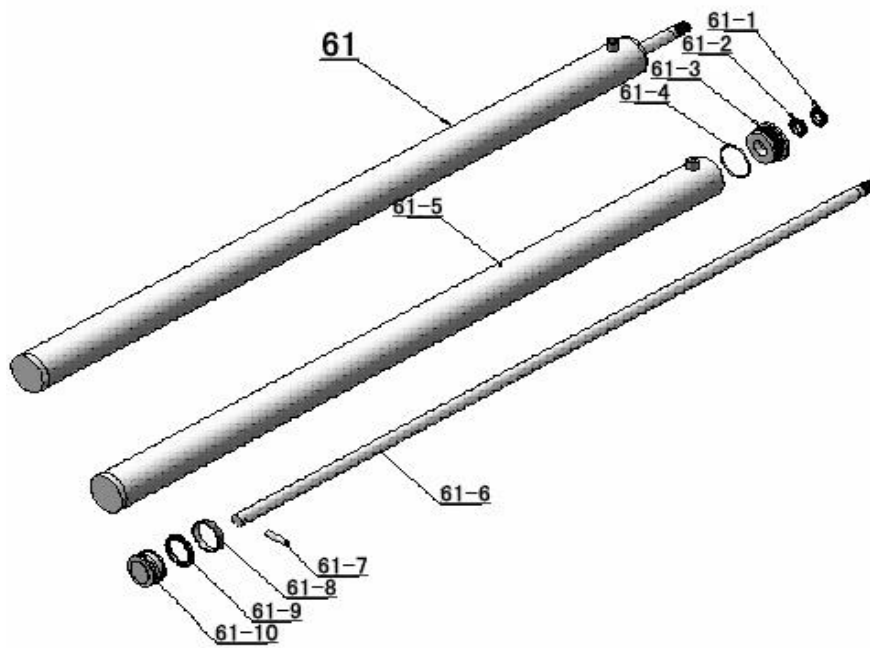
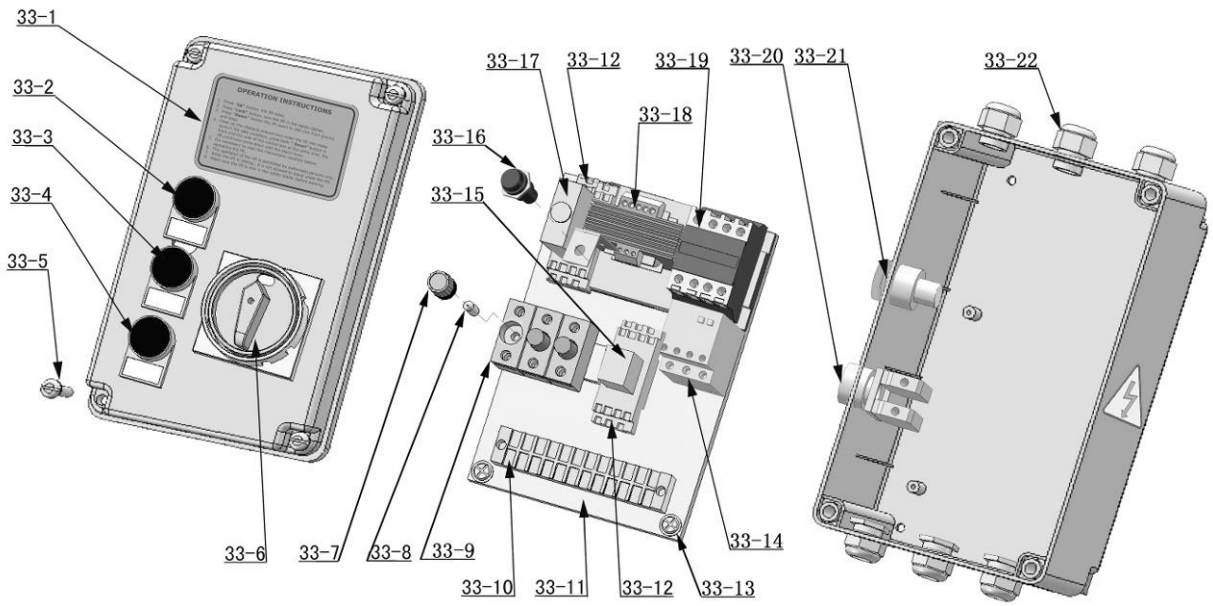


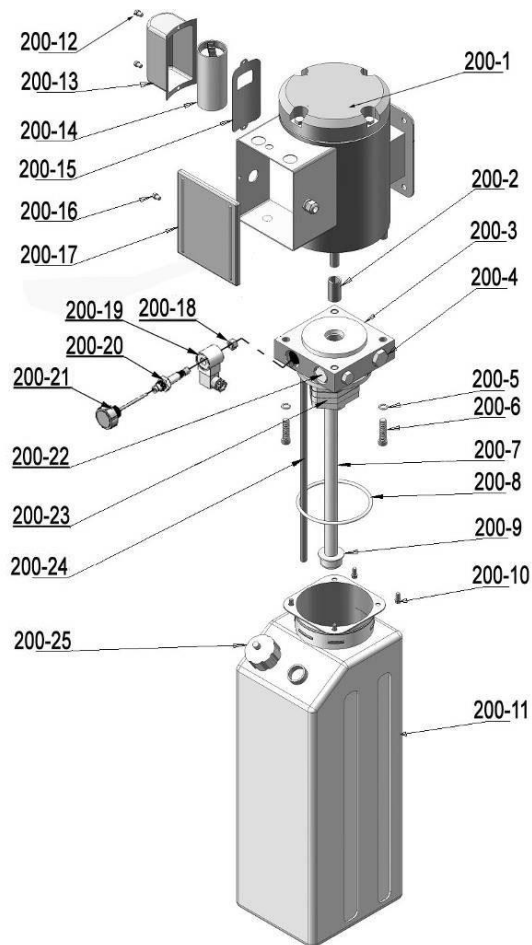
Fig. 48

## CONTROL BOX



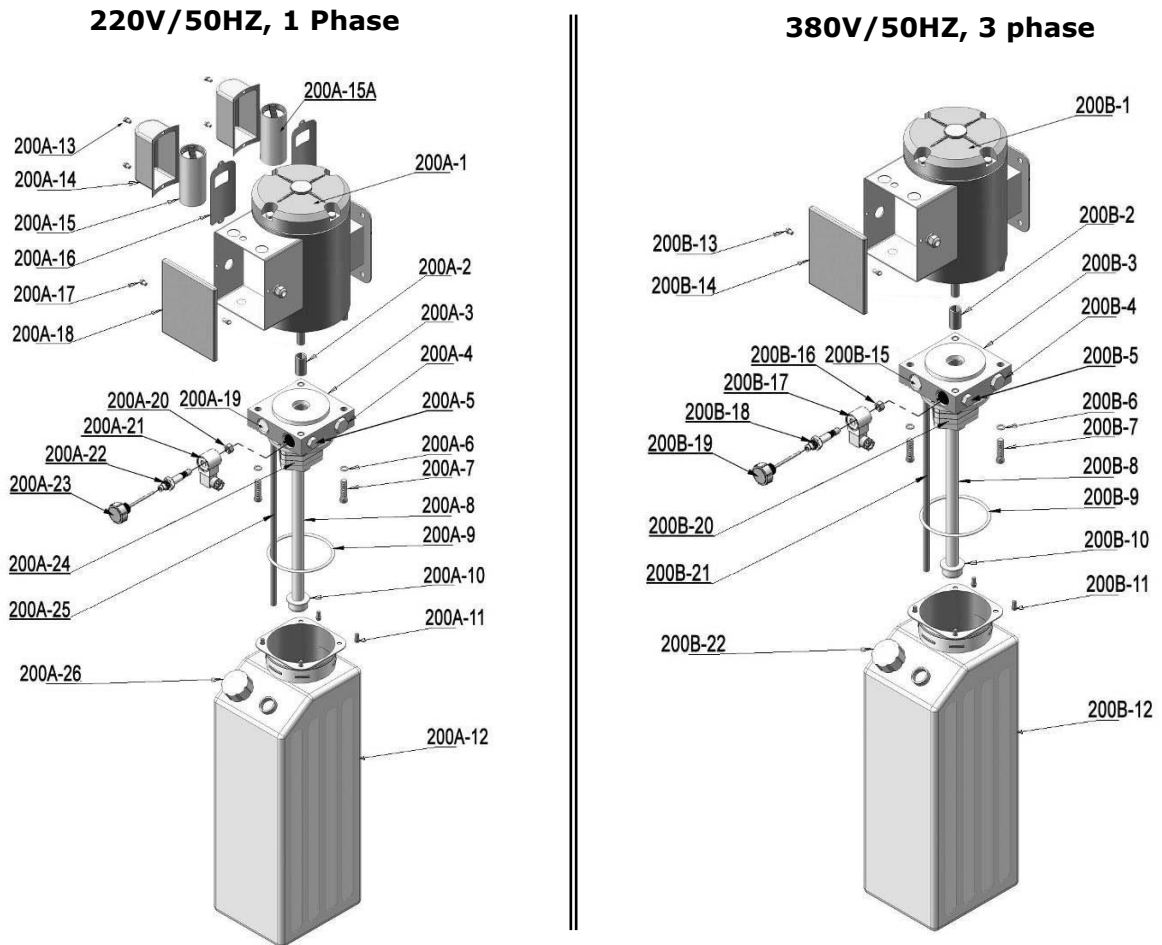
**Fig. 49**

## SPX ELECTRIC POWER UNIT 220V/50HZ, single phase (Fig. 50)



**Fig. 50**

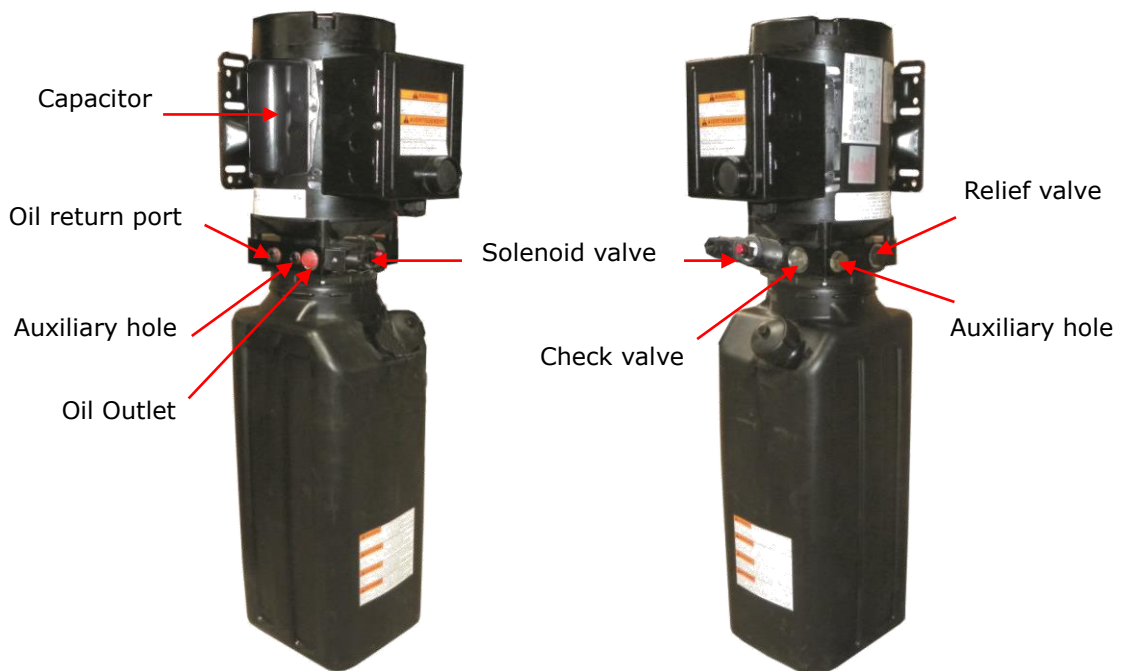
**INDYPRO ELECTRIC POWER UNIT (Fig. 51)**



**Fig. 51**

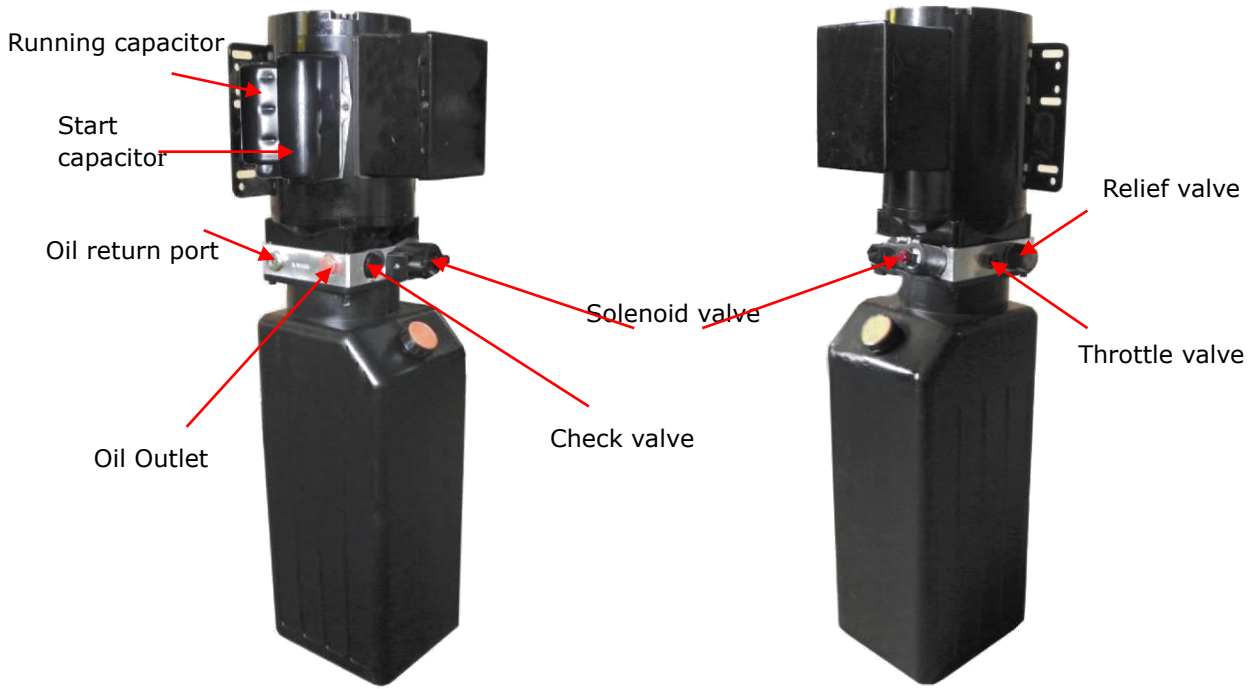
**Illustration of hydraulic valve for SPX & INDYPRO hydraulic power unit**

**a. SPX Electric power unit, 220V/50HZ, Single phase (See Fig. 52)**



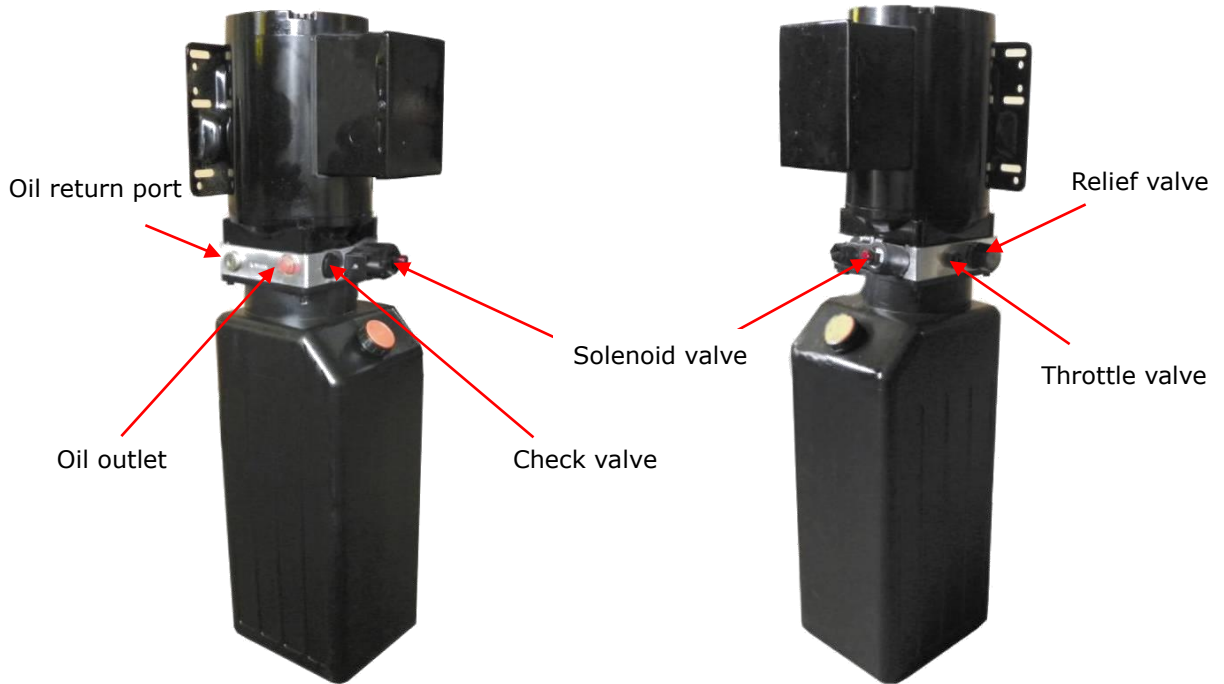
**Fig. 52**

**b. INDYPRO electric power unit, 220V/50HZ, 1 phase (See Fig. 53)**



**Fig. 53**

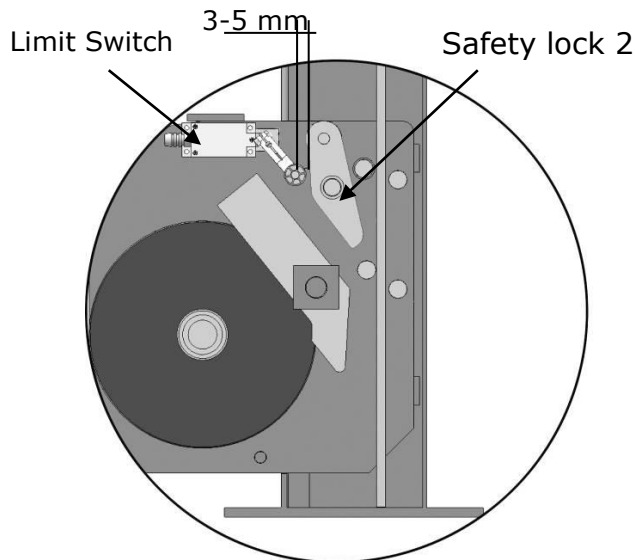
**C. INDYPRO electric power unit, 380V/50HZ, 3 phase (See Fig. 54)**



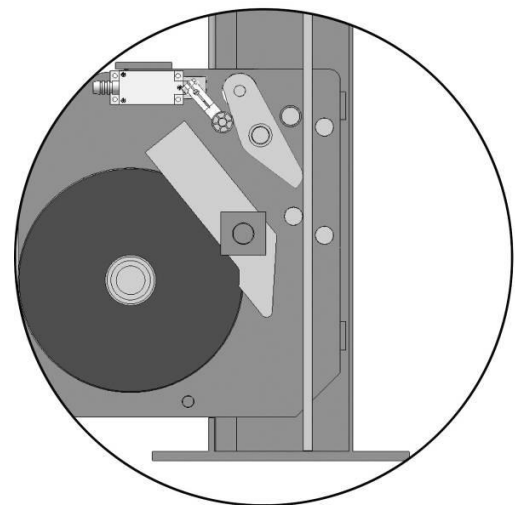
**Fig. 54**

## V. TEST RUN:

1. Fill the reservoir with approximately 12L Hydraulic Oil (**Note:** In consideration of Power Unit's durability, please use **Hydraulic Oil 46#**).
2. Press button **UP ↑** the Cables will be strained. Check whether the Cables match the Pulley. Make sure the Cables are not across.
3. Press self-lock button **Lock ↓**, the Cross-beam will be locked to the safety ladders, and then adjust the platforms to be level by adjusting the nuts of Safety Ladders.
4. Adjust the cable fitting Hex nuts to make platforms and four safety locks work synchronously. You need to run the lift up and down for several times, meanwhile do the synchronous adjustment till the four Safety Devices can lock and release at the same time.
5. Adjust the clearance between the post and the plastic slider of Cross-beam to about 2 mm, and then tighten the fixing nut of slider.
6. Adjust Limit Switch on Cross Beam:
  - 6.1 Press button **UP ↑**, the Cables will be strained. Check whether the distance between lever of Limit Switch on Cross Beam and the Slack-cable safety lock is about 5 mm. If not, please adjust the distance correctly (**See Fig. 55**).
  - 6.2 Press self-lock button **Lock ↓**, the Cross-beam will be locked to the safety ladders, and the cables are released, Check whether lever of Limit Switch on Cross Beam touch the Slack-cable safety lock and whether Limit Switch is open completely. If not be opened, then adjust the lever of limit switch till the Slack-cable safety lock can completely open the switch (**See Fig. 56**).



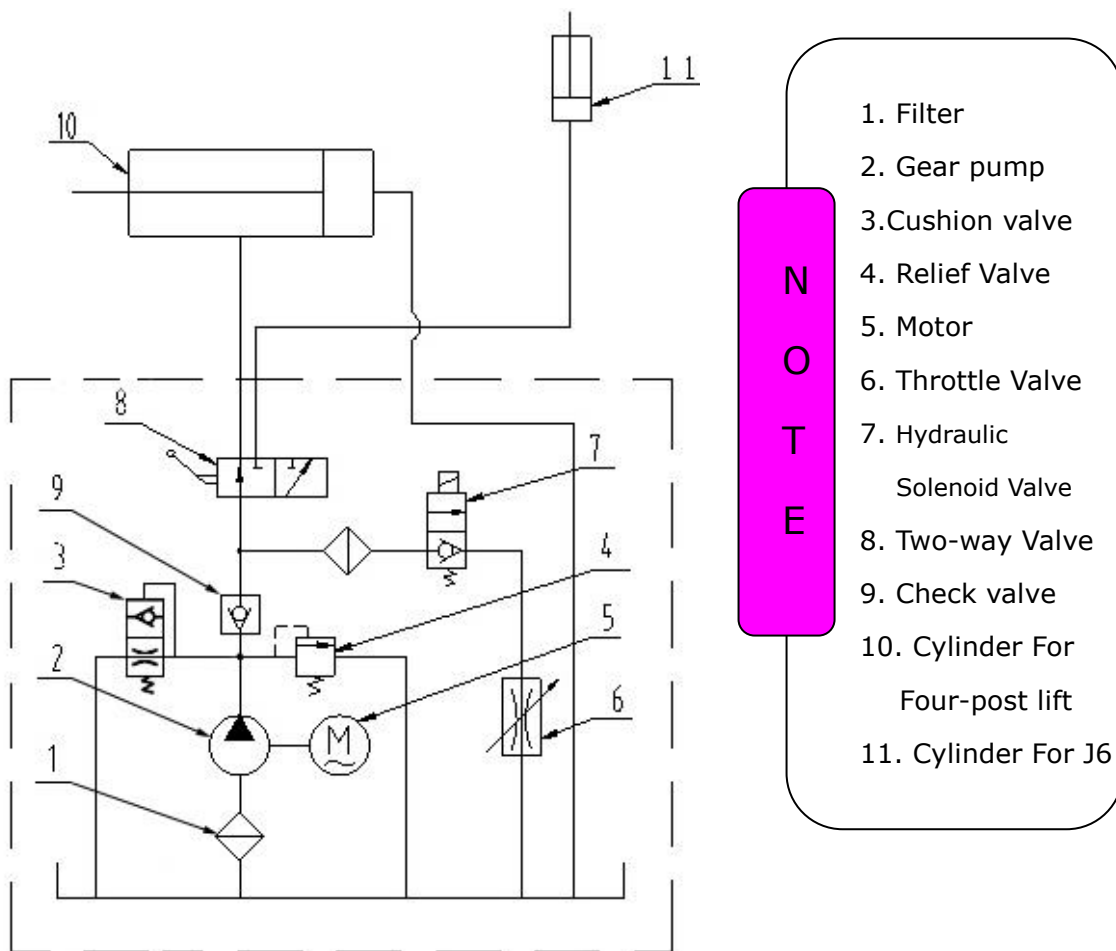
**Tighten cable**  
**Fig. 55**



**Release cable**  
**Fig. 56**

7. After finishing the above adjustment, test running the lift with load. Run the lift with Platforms in low position first, make sure the Platforms can rise and lower synchronously and the Safety Device can lock and release synchronously. And then test run the lift to the top completely. If there are anything improper, repeat the above adjustment.

### Circuit Diagram of Hydraulic System



N  
O  
T  
E

**Fig. 57**

**Remark: The Two-way valve No. 8 is specially for the optional power unit drive rolling Jack model J6E only.**

## VI. OPERATION INSTRUCTIONS

### To lift vehicle

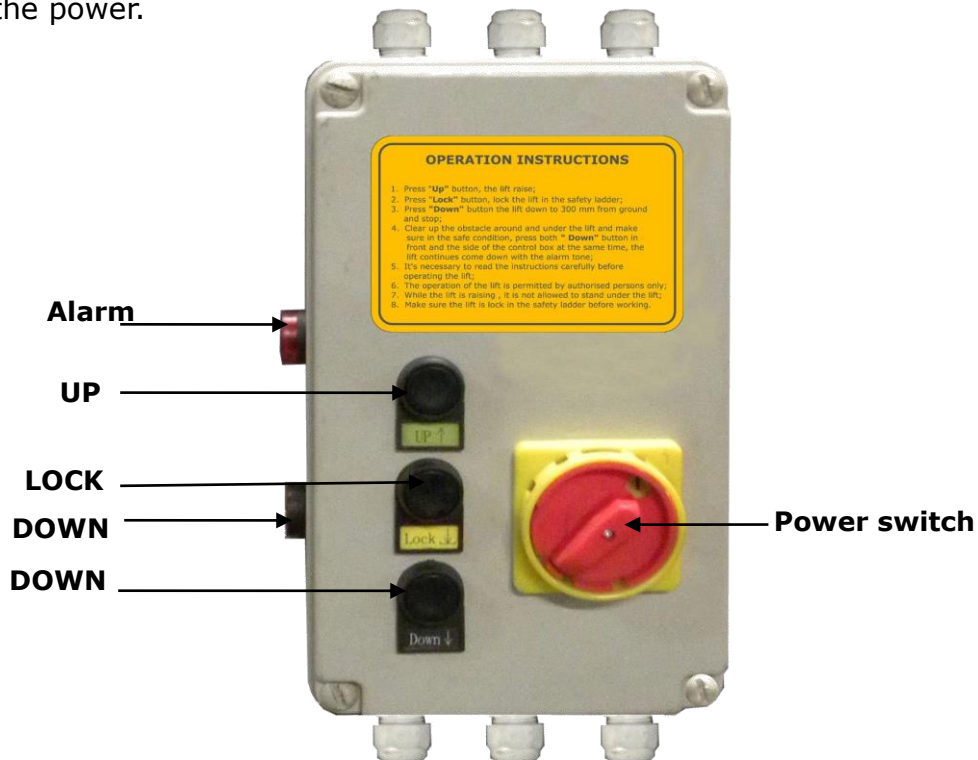
1. Keep clean of environment near the lift;
2. Drive vehicle to the Platform and put on the brake;
3. Turn on the power and press the button **UP ↑**, raise the lift to the working position;

**Note: make sure the vehicle is steady when the lift is raised.**

4. Press the button **LOCK ↓**, lock the lift in the safety position. Make sure the Safety device is locked at the same height.

### To lower vehicle

1. Be sure the clearance of around and under the lift, only leaving operator in lift area;
2. Press the button **DOWN ↓**, the lift will be raised for 3-5 seconds, and then the safety device would be released and the lift starts being lowered automatically;
3. The lift will be stopped automatically when coming down to about 300 mm to ground, check around and make sure it is safety and no any obstacle under the lift, then push both **DOWN ↓** buttons (one on the side) at the same time, the lift would be lowered with the tone alarm;
4. Drive away the vehicle when the lift is lowered to the lowest position;
5. Turn off the power.



**Fig. 58**



## **VII. MAINTENANCE SCHEDULE**

### **Monthly:**

1. Re-torque the anchor bolts to 150Nm;
2. Lubricate cable with lubricant;
3. Check all cable connection, bolts and pins to insure proper mounting;
4. Make a visual inspection of all hydraulic hoses/lines for possible wear or leakage;
5. Lubricate all Rollers, Safety devices with 90wt. gear oil or equivalent.

**Note: All anchor bolts should take full torque. If any of the bolts does not function for any reason, DO NOT use the lift until the bolt has been replaced.**

### **Every six months:**

1. Make a visual inspection of all moving parts for possible wear, interference or damage.
2. Check and adjust as necessary, equalizer tension to insure level lifting.
3. Check columns for plumbness.

## VIII. TROUBLE SHOOTING

<b>TROUBLE</b>	<b>CAUSE</b>	<b>REMEDY</b>
Motor does not run	<ol style="list-style-type: none"> <li>1. Button does not work</li> <li>2. Wiring connections are not in good condition</li> <li>3. Motor burned out</li> <li>4. AC contactor burned out</li> <li>5. Height limit switch is damaged</li> </ol>	<ol style="list-style-type: none"> <li>1. Replace button</li> <li>2. Repair all wiring connections</li> <li>3. Repair or replace motor</li> <li>4. Replace AC contactor</li> <li>5. Replace</li> </ol>
Motor runs but the lift is not raised	<ol style="list-style-type: none"> <li>1. Motor runs in reverse rotation</li> <li>2. Hydraulic solenoid valve in damage</li> <li>3. Gear pump in damage</li> <li>4. Relief valve or check valve in damage</li> <li>5. Low oil level</li> </ol>	<ol style="list-style-type: none"> <li>1. Reverse two power wire</li> <li>2. Repair or replace</li> <li>3. Repair or replace</li> <li>4. Repair or replace</li> <li>5. Fill tank</li> </ol>
Lift does not stay up	<ol style="list-style-type: none"> <li>1. Solenoid valve out of work</li> <li>2. Relief valve or check valve leakage.</li> <li>3. Cylinder or fittings leaks</li> </ol>	Repair or replace
Lift raises too slow	<ol style="list-style-type: none"> <li>1. Oil line is jammed</li> <li>2. Motor running on low voltage</li> <li>3. Oil mixed with Air</li> <li>4. Pump leaks</li> <li>5. Overload lifting</li> </ol>	<ol style="list-style-type: none"> <li>1. Clean the oil line</li> <li>2. Check electrical system</li> <li>3. Fill tank</li> <li>4. Replace Pump</li> <li>5. Check load</li> </ol>
Lift cannot lower	<ol style="list-style-type: none"> <li>1. Air solenoid valve damaged</li> <li>2. Hydraulic solenoid valve damaged</li> <li>3. Air Cylinder damaged</li> <li>4. Air -line leaked</li> </ol>	<ol style="list-style-type: none"> <li>1. Replace or repair</li> <li>2. Replace or repair</li> <li>3. Replace the cylinder</li> <li>4. Check the air-line</li> </ol>

## IX. PARTS LIST FOR TFP09A

Item	Part#	Description	QTY.	Note
1	420011A	Powerside Column	1	
2	420002	Offside Column	3	
3	420252	Cross Beam assy.	2	
4	420239	Limit block	1	
5	209059	Anchor Bolt	16	
6	410022	Safety Ladder	4	
7	420175A	Hex Nut	16	
8	430003	Powerside Platform	1	
9	420022A	Pulley Shaft Weldment	2	
10	420023A	Washer	12	
11	420024B	Pulley	10	
11A	420132A	Bronze Bush for Pulley	10	
12	209043	Hex Bolt	12	
13	209034	Lock Washer	2	
14	420144	Washer	2	
15	420030	Hex Bolt	12	
16	420137	Lock Washer	12	
17	420029	Washer	12	
18	430001	Offside Platform	1	
19	420020B	Hex Bolt	4	
20	420145	Oil-water Separator	1	
21	420146	Straight Fitting for Air Line	1	
22	209009	Cup Head Bolt	10	
23	420076	90 <sup>0</sup> Fitting for Air Line	1	
24	201034	Bleeding Plug	1	
25	420147	Straight Fitting for Air Line	1	
26	420077	Air Solenoid Valve	1	
27	420148	Washer	2	
28	420149	Cup Head Bolt	2	
29	420150	Cover of Air Solenoid Valve	1	
30	420045	Washer	28	
31	420151	Straight Fitting for Air Line	1	
32	420018	Self locking Nut	6	
33	420016	Control Box	1	
34	420153	Cup Head Bolt	9	
200	420019	Electric Power Unit	1	
36	209005	Self locking Nut	14	
37	209004	Rubber Ring	8	
38	209003	Hex Bolt	4	
39	420152	Washer	18	
40	206011	Cup Head Bolt	18	
41	420251	Limit Switch	2	
42	420010A	Fixing Plate For Limit Switch	1	
43	420225	High limit switch assy. 	1	
44	420203	Fixing Plate For Limit Switch	1	

Item	Part#	Description	QTY.	Note
45	420204	Wire protective cover	1	
46	420156	Protecting Rubber Ring	1	
47	420004	Pin for Drive-in Ramp	2	
48	420005	Fixing Bolt	4	
49A	430002	Drive-in Ramp	2	
49B	620063	Roller for drive-in Ramp	4	
49C	620043	Roller pin for drive-in Ramp	4	
49D	209010	Ø10 Snap ring	8	
50	420031	Tire Stop Plate	2	
51	420226	Lower limit switch assy. ④	1	
52	209066	Hex Nut	4	
55	430004	Plate for Adjustable Turnplate	4	
56	430006	Pin For Slip Plate	4	
57	430007	Slip Plate	2	
58	420157	Steel Ball Set	42	
59	420007	Platform Lock Plate	4	
60	410090	Fixing Ring For Oil Cylinder	1	
61	410081	Oil Cylinder	1	
62	420013	Cylinder Connecting Plate	1	
63	420014	Hex Nut	1	
64	201005	Split Pin	1	
64A	620065/ 201090	Shim	20/20	
64B	209056	M10 Self locking Nut	4	
64C	420217	Cable Limit Pin	4	
<b>Parts for Circuit system</b>				
65	420009A	Protecting Plastic Hose	1	
66	420009B	Protecting Plastic Hose	1	
67	420016B	Protecting Plastic Hose	1	
68	420249	Wire Cable ①	1	
69	420250	Wire Cable ②	1	
70	420168	White Winding Tape	1	
71	420016A	Wire cable	1	
72	420205	Wire cable	2	
73	430500	Parts box	1	
<b>Optional Parts</b>				
74	420158	Turnplate	2	
<b>Parts For Cable</b>				
75	420115B	No.① Cable	1	
76	420116B	No.② Cable	1	
77	420114B	No.③ Cable	1	
78	420117B	No.④ Cable	1	

<b>Parts For Hydraulic System</b>				
79	420166	90° Fitting	1	
80	420243	Fitting	1	
80A	420245	Fitting	1	
80B	209119	Compensation Valve	1	
80C	201020	90° Fitting	1	
81	420246	Oil Hose	1	
82	420120	Extended Straight Fitting (with Nut)	1	
83	207026	Oil Hose	1	
84	209060	90° Fitting For Hydraulic Power Unit	1	
85	420095	Straight Fitting	1	
<b>Parts For Air Line System</b>				
86	420124	T-Fitting For Air Line	2	
87	420242	T-Fitting For Air Line	1	
88	420241	Straight Fitting For Air Line	1	
89	420195	Oil return hose	1	
89A	420131A	Black Air Line	1	
90	420167	Black Air Line	1	
<b>Parts For Cross Beam</b>				
3-1	420254	Cross Beam	2	
3-2	420051B	Pulley Safety Cover	4	
3-3	209009	Cup Head Bolt	8	
3-4	420044	Limit Plate	4	
3-5	420138	Socket Bolt	8	
3-6	420038	Pin	12	
3-7	420037	Snap Ring	24	
3-8	420033	Spring	4	
3-9	209021	Hex Nut	8	
3-10	420049	Split Pin	4	
3-11	420048	Air Cylinder	4	
3-12	420047	Fitting for Air Cylinder	4	
3-13	420046	Split Pin	8	
3-14	420042	Plastic Slider	8	
3-15	209033	Washer	24	
3-16	420043	Socket Bolt	16	
3-17	420175	Slack-cable safety lock (left & right )	2/ea.	
3-18	420171	Pin	8	
3-19	420172	Pin Bush For Slack-cable safety lock	8	
3-20	206019	Snap Ring	16	
3-21	209010	Snap Ring	4	
3-22	420035	Tension Pulley	4	
3-23	420174	Spacer	4	
3-24	420041A	Pulley Pin	4	
3-25	420040A	Pulley Bush	4	

Item	Part#	Description	QTY.	Note
<b>Parts For Cylinder</b>				
61-1	420059	Dust Ring	1	
61-2	420060	Y- Ring	1	
61-3	410082	Head Cap	1	
61-4	410083	O- Ring	1	
61-5	410084	Bore Weldment	1	
61-6	420064	Piston Rod	1	
61-7	410085	Pin	1	
61-8	410086	Support Ring	1	
61-9	410087	Y- Ring	1	
61-10	410088	Piston	1	
<b>Parts For Control Box</b>				
33-1	420069A	Cover Of Control Box	1	
33-2	420071	Button <b>UP</b>	1	
33-3	209099A	Button <b>Lock</b>	1	
33-4	420072	Button <b>Down</b>	1	
33-5	420139	Screw	4	
33-6	420074	Power Switch (QSI)	1	
33-7	420085	Fuse Cap	3	
33-8	420086	Fuse (FU1)	3	
33-9	420087	Fuse Base	3	
33-10	420075A	Terminal Group	1	
33-11	420133A	Panel for Installing Element	1	
33-12	420135	Thermal Relay Connectors	2	
33-13	420073	Cup Head Bolt	4	
33-14	420140	Thermal Relay (FR)	1	
33-15	420141	Intermediate Relay (KA)	1	
33-16	420176	Fuse Protector (FU2)	1	
33-17	420083	Timer Relay (KT)	1	
33-18	420134	Transformer (TC)	1	
33-19	420084A	24V AC Contactor (KM)	1	
33-20	420142	Button <b>Down (K)</b>	1	
33-21	420143	Alarm Lamp (H)	1	
33-22	420088	Fitting For White Wire Cable	6	

<b>Parts For SPX Electric Power Unit 220V/50HZ/1 Phase</b>				
<b>Item</b>	<b>Part#</b>	<b>Description</b>	<b>QTY.</b>	<b>Note</b>
200-1	81400185	Motor	1	
200-2	81400063	Motor Connecting Shaft	1	
200-3	81400186	Valve Body	1	
200-4	81400160	Relief Valve	1	
200-5	81400161	Lock Washer	4	
200-6	81400162	Socket Bolt	4	
200-7	81400121	Inlet Pipe	1	
200-8	81400163	O-ring	1	
200-9	81400164	Filter	1	
200-10	81400165	Hex Bolt	4	
200-11	81400093	Reservoir	1	
200-12	81400166	Cross Bolt	2	
200-13	81400167	Cover for Capacitor	1	
200-14	81400029	Capacitor	1	
200-15	81400168	Rubber Gasket	1	
200-16	81400169	Hex Bolt	1	
200-17	81400062	Cover of Motor Terminal Box	1	
200-18	81400187	Hydraulic Solenoid Valve Nut	1	
200-19	81400188	Hydraulic Solenoid Valve Coil	1	
200-20	81400056	Hydraulic Solenoid Valve Body	1	
200-21	81400189	Release Adjusting Bar	1	
200-22	81400043	Check Valve	1	
200-23	81400123	Gear Pump	1	
200-24	81400122	Oil Return Pipe	1	
200-25	81400172	Filler Cap	1	



<b>Parts For INDYPRO Electric Power Unit 220V/50HZ/1 Phase</b>				
200A-1	81400190	Motor	1	
200A-2	81400127	Motor Connecting Shaft	1	
200A-3	81400198	Valve Body	1	
200A-4	81400106	Relief Valve	1	
200A-5	81400107	Throttle Valve	1	
200A-6	209149	Lock Washer	4	
200A-7	81400148	Socket Bolt	4	
200A-8	81400134	Inlet Pipe	1	
200A-9	81400144	O-ring	1	
200A-10	81400150	Filter	1	
200A-11	81400145	Socket Bolt	4	
200A-12	81400024	Reservoir	1	
200A-13	420148	Cup Head Bolt	4	
200A-14	81400066	Cover for Capacitor	2	
200A-15	81400130	Start Capacitor	1	
200A-15A	81400088	Run Capacitor	1	
200A-16	81400180	Rubber Gasket	2	
200A-17	420148	Cup head Bolt	2	
200A-18	81400050	Cover of Motor Terminal Box	1	
200A-19	81400192	Check Valve	1	
200A-20	81400193	Hydraulic Solenoid Valve Nut	1	
200A-21	81400194	Hydraulic Solenoid Valve Coil	1	
200A-22	81400195	Hydraulic Solenoid Valve Body	1	
200A-23	81400196	Release Adjusting Bar	1	
200A-24	81400041	Gear Pump	1	
200A-25	81400084	Oil Return Pipe	1	
200A-26	81400113	Filler Cap	1	

<b>Parts For INDYPRO Electric Power Unit 380V/50HZ/3 Phase</b>				
200B-1	81400197	Motor	1	
200B-2	81400127	Motor Connecting Shaft	1	
200B-3	81400198	Valve Body	1	
200B-4	81400106	Relief Valve	1	
200B-5	81400107	Throttle Valve	1	
200B-6	209149	Lock Washer	4	
200B-7	81400148	Socket Bolt	4	
200B-8	81400134	Inlet Pipe	1	
200B-9	81400144	O-ring	1	
200B-10	81400150	Filter	1	
200B-11	81400145	Socket Bolt	4	
200B-12	81400024	Reservoir	1	
200B-13	420148	Cup head Bolt	2	
200B-14	81400050	Cover of Motor Terminal Box	1	
200B-15	81400192	Check Valve	1	
200B-16	81400193	Hydraulic Solenoid Valve Nut	1	
200B-17	81400194	Hydraulic Solenoid Valve Coil	1	
200B-18	81400195	Hydraulic Solenoid Valve Body	1	
200B-19	81400196	Release Adjusting Bar	1	
200B-20	81400041	Gear Pump	1	
200B-21	81400084	Oil Return Pipe	1	
200B-22	81400113	Filler Cap	1	

<b>Parts for Optional Air line kits</b>				
201-1	61K090	C Fitting	2	
201-2	61K091	Air hose connector	2	
201-3	430010	Washer	2	
201-4	61K092	Hex bolt	2	
201-5	209136A	Air hose	1	
201-6	61K094	90 Fitting	1	
201-7	61K093	T-fitting	1	
201-8	430011	Straight fitting	1	
201-9	430012	Straight fitting	1	
201-10	420146	Straight fitting	2	
201-11	520065A	Air hose(spring)	2	
201-12	430013	T-fitting	1	
	61K070A	Ties	2	



Exclusively for: TOMAD International, Inc. 8847 Commerce Park Place Suite A,  
Indianapolis 46268 - USA Tel: (317) 8 7 0-1199 Fax: (317) 8 7 6 -7344  
**[www.indypro.us](http://www.indypro.us)**