

FEATURES

- Heavy-Duty 4-Post Lift with 9,000 lbs. lifting capacity
- Electric-air control operation system
- Mechanical self-lock and air-driven safety release
- Electrical hydraulic power system, cable-driven
- Skid proof diamond platform
- Two adjustable turntable positions to fit the different wheel base
- Adjustable platform and adjustable safety lock ladders
- Dual safety device : In case the primary safety locks are out of operation, the lift would also be locked automatically by a second safety device
- Optional Jack and Turnplate

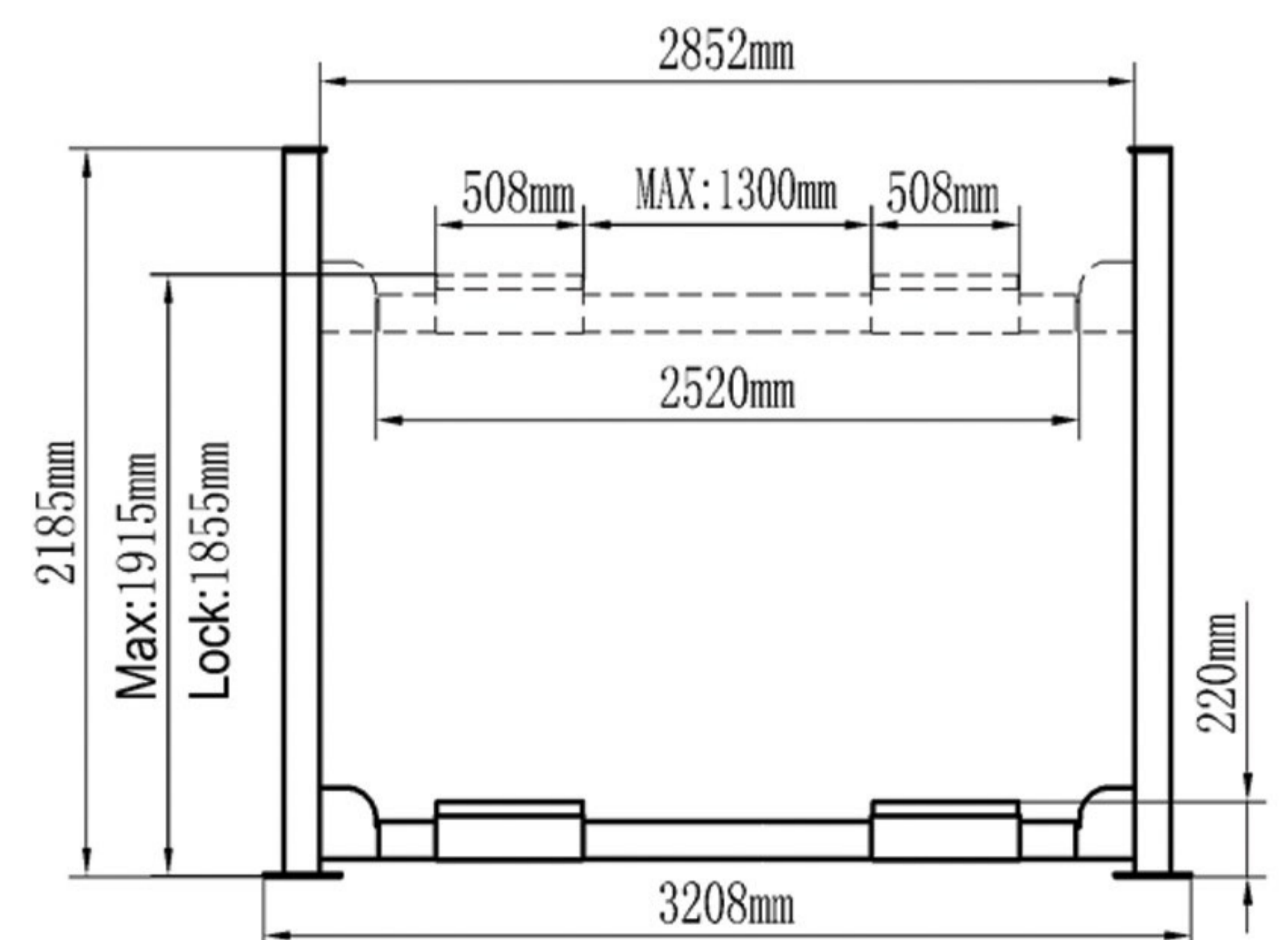
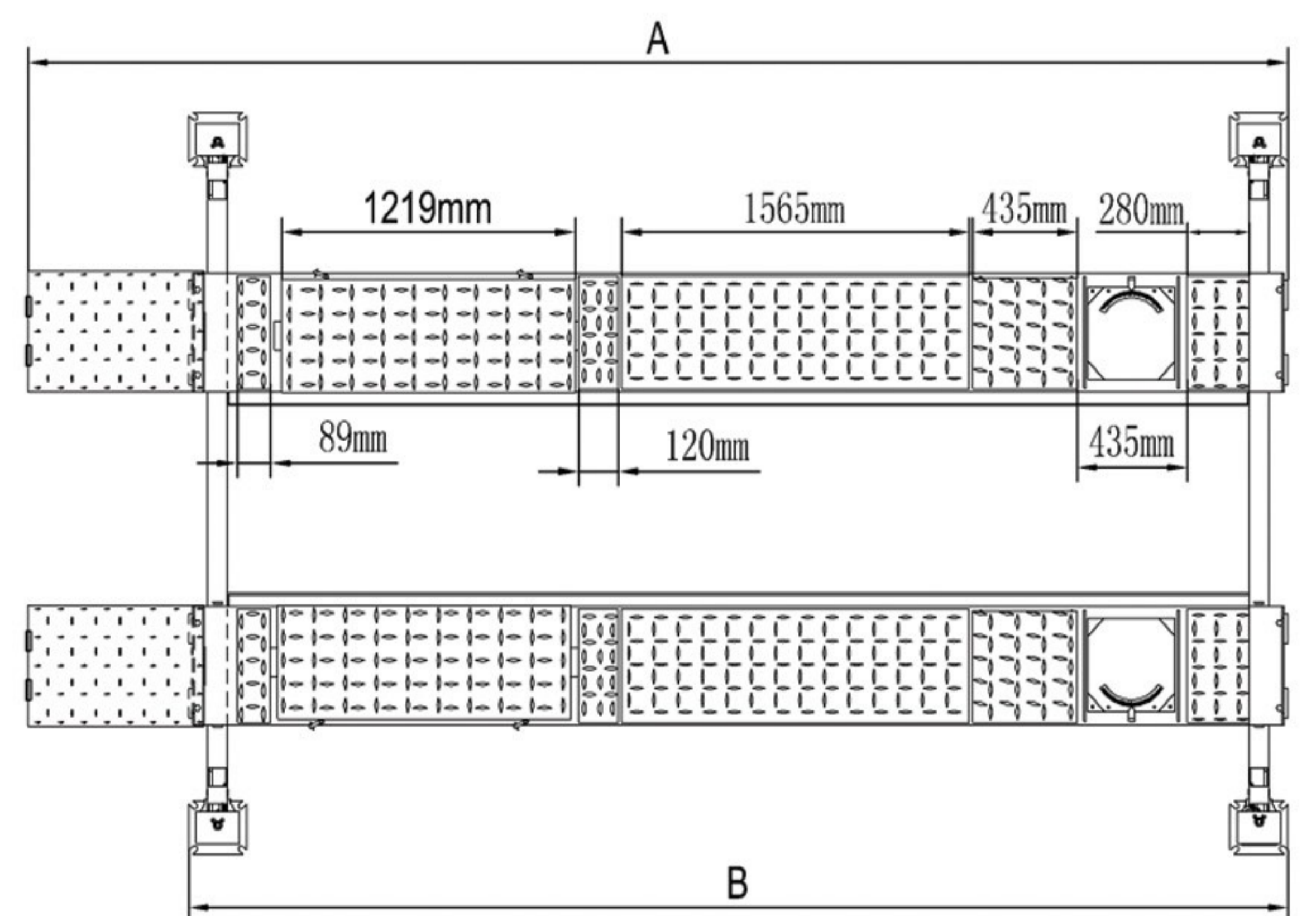

// SPECIFICATIONS

| Model | Lifting Capacity | Lifting Time | A | B | C | D | E | Gross Weight | Motor |
|--------|-------------------|--------------|----------------------------|---------------------------|--------------------|-----------------------|------------------|----------------------|------------|
| | | | Overall Length (Inc Ramps) | Overall Length (No Ramps) | Overall Width | Width Between Columns | Lifting Height | | |
| TFP09 | 4.0T (9,000 lbs.) | 45 Seconds | 5512 mm (217) | 4600 mm (181 1/8") | 3208mm (126- 1/4") | 2852mm (112-1/4") | 1865mm (73 1/2") | 945 Kg (2,083 lbs.) | 2.0/3.0 HP |
| TFP09A | 4.0T (9,000 lbs.) | 45 Seconds | 5512 mm (217) | 4600 mm (181 1/8") | 3208mm (126- 1/4") | 2852mm (112-1/4") | 1915mm (75 3/8") | 1155 Kg (2,546 lbs.) | 2.0/3.0 HP |

// DETAILS



EXCLUSIVE FEATURE!

Electric Control Device With UP LOCK and DOWN buttons

With C.E. stop switch at 300 mm from ground and alarm tone when lowering down from 300 mm to ground make the lift more safety.

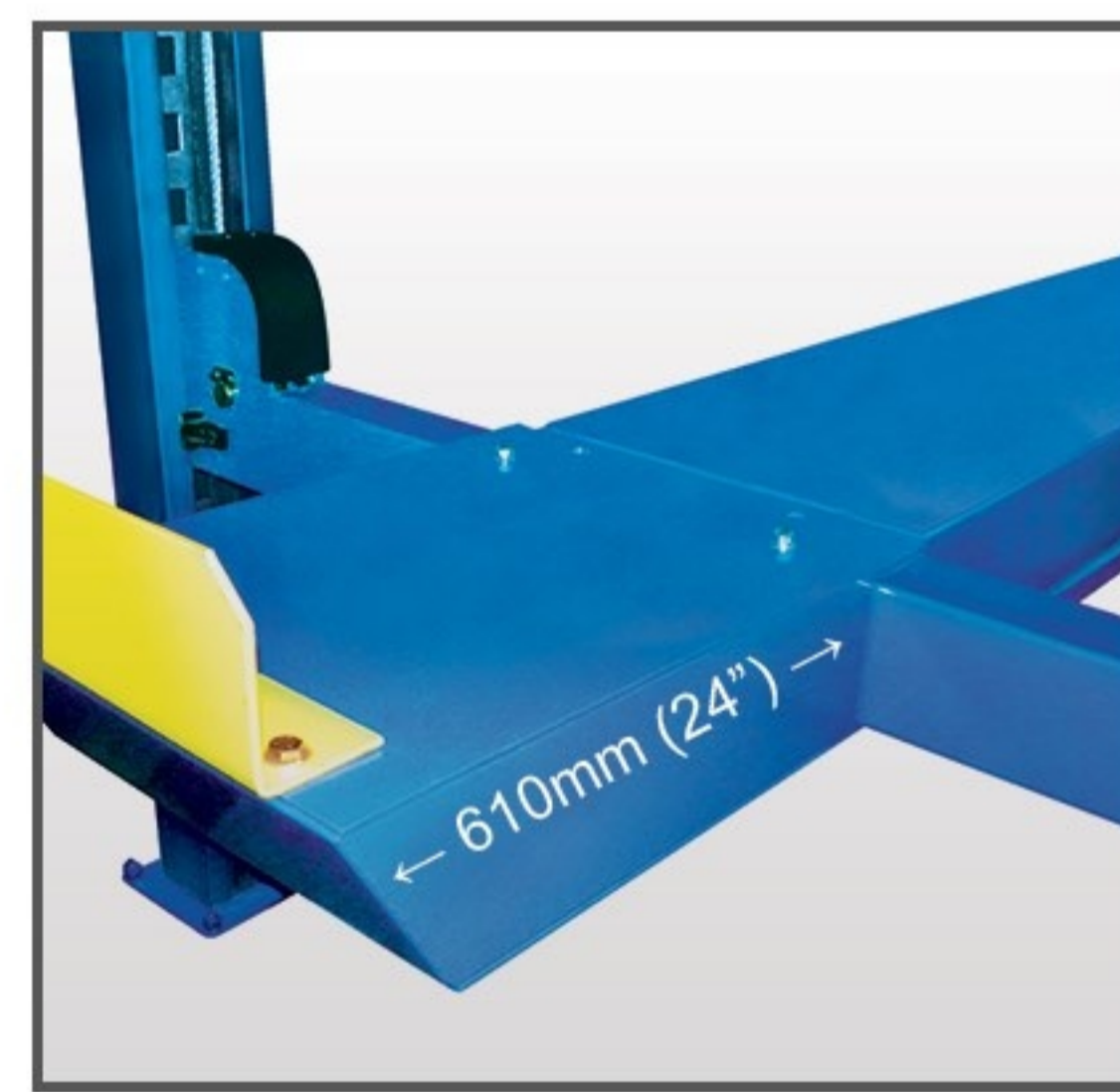

Optional

Extension platform for model TFP14 to add the length of platform up to 610mm (24")



Even though all cylinders are flow restricted inside, we are adding the flow controlled valve to control the lowering speed for the heavy-duty line four post lifts model TFP09 and TFP09



Optional Air Line Kits

All four post lifts are designed to use the air line kits for rolling jack.

kits No: 40102



Oil-water separator and Solenoid Air Valve are installed outside the control box



Optional

Rolling Jack RJ-7A with SPX Air pump and 1.5" 3" extension adapters included

Capacity: 7,000 Lbs. (3.2T)