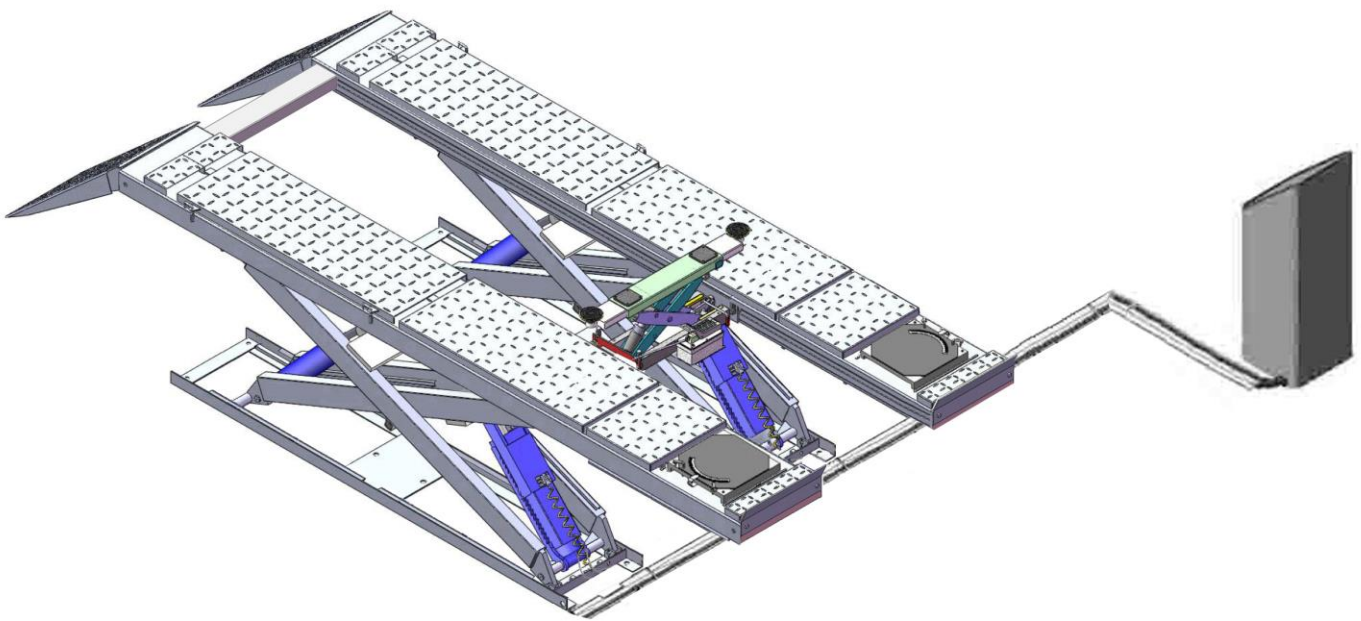




# **INDYPRO**

## **LIFTS & EQUIPMENT**



**TLX12/TLX12A**

**Installation/Operation/Service Manual**

# CONTENTS

Product Features and Specifications .....	1
Installation Requirement .....	3
Steps of Installation .....	4
Exploded View .....	23
Test Run .....	28
Operation Instruction .....	29
Maintenance .....	30
Trouble Shooting .....	32
Parts List .....	33

# I. PRODUCT FEATURUES AND SPECIFICATIONS

## Professional Alignment Scissors Lift

### Model TLX12A

- Electric- air control system, safety self-lock mechanism
- 2-Dual synchronous cylinders are applied to assure the lifting level on both platforms
- Non-skid diamond runway
- Integrated rear slip-plates
- Heavy duty design, fit for a wide range of vehicle car to van and light truck.
- Optional Jack (with hand pump/air-operated hydraulic pump)
- Optional Turnplate

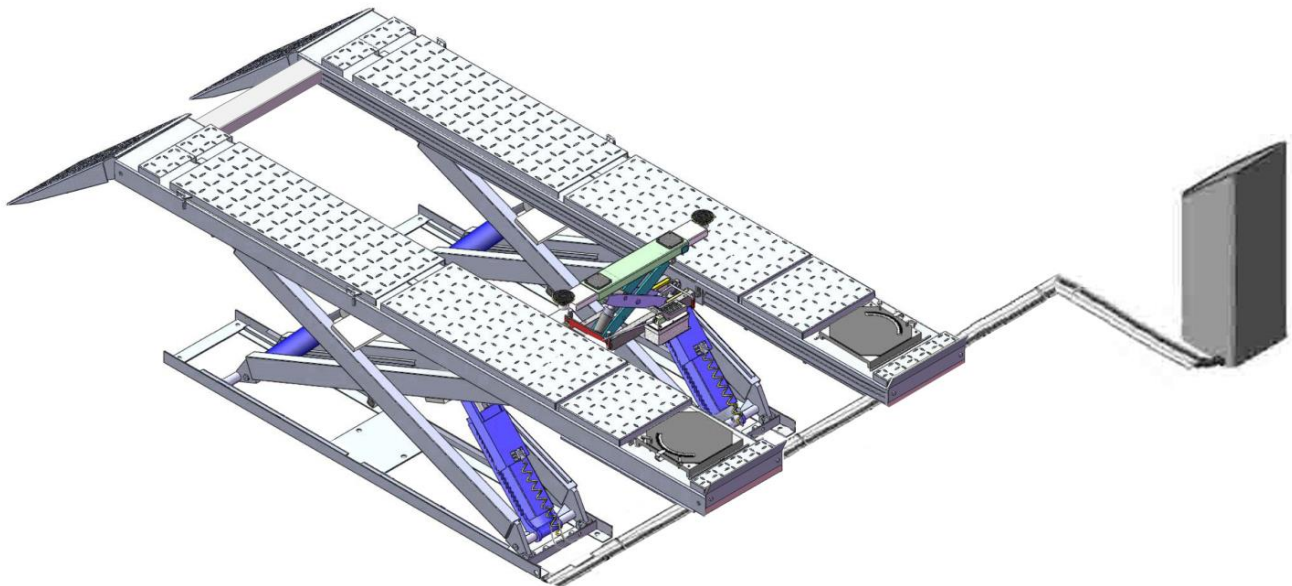


Fig. 1

### MODEL TLX12A SPECIFICATIONS

Model	Lifting Capacity	Lifting Height	Min. Height	Lifting Time	Overall Length (Inc.Ramps)	Runway Length	Overall Width	Runway Width	Distance Between Baseplate	Gross Weight	Motor
TLX12A	5.5T 12000 lbs	1870mm 73 5/8"	300mm 11 3/4"	58S	6554mm 258"	5018mm 197 1/2"	2290mm 90 1/8"	625mm 24 5/8"	955mm 37 5/8"	2320Kg 5105 lbs	4.0HP

## Professional non-alignment Scissors Lift

### Model TLX12

- Electric- air control system, safety self-lock mechanism
- Dual synchronous cylinders are applied to assure the lifting level on both platforms
- Non-skid diamond runway
- Heavy duty design, fit for a wide range of vehicle car to van and truck
- Optional Jack (with hand pump/air-operated hydraulic pump)

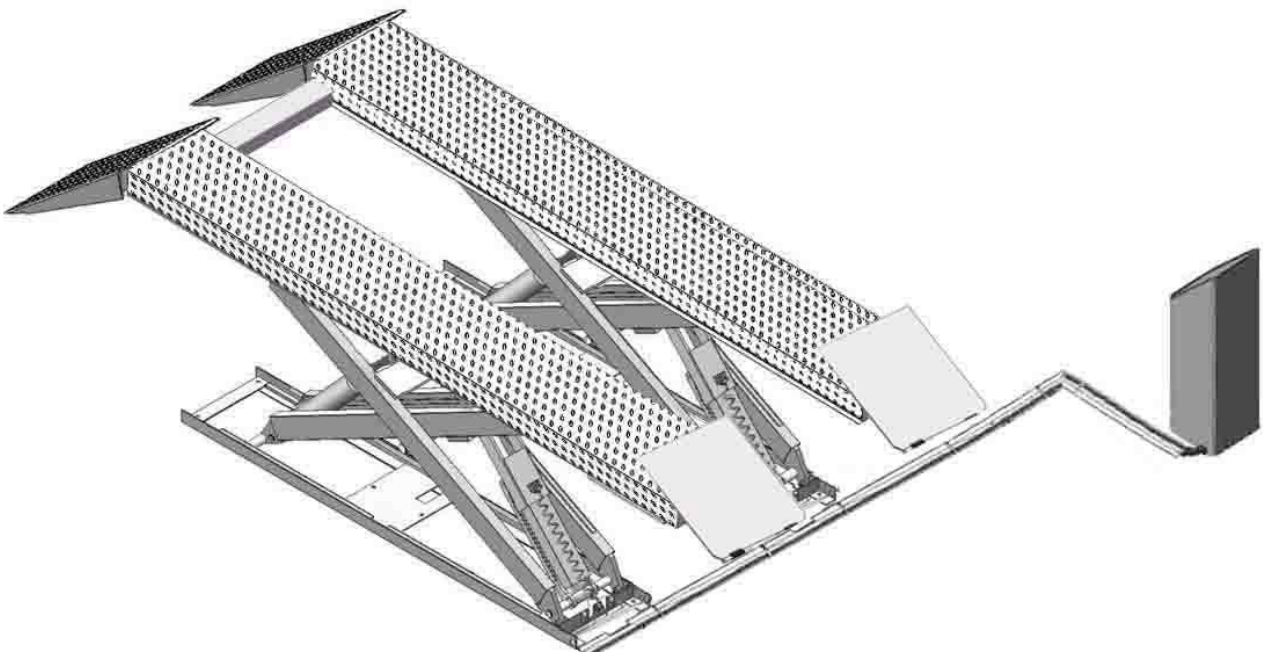


Fig. 2

### MODEL TLX12(X550) SPECIFICATIONS

Model	Lifting Capacity	Lifting Height	Min. Height	Lifting Time	Overall Length (Inc. Ramps)	Runway Length	Overall Width	Runway Width	Distance Between Baseframe	Gross Weight	Motor
TLX12	5.5T 12000 lbs	1870mm 73 5/8"	300mm 11 3/4"	58S	6784mm 267"	5018mm 197 1/2"	2290mm 90 1/8"	625mm 24 5/8"	955mm 37 5/8"	2058Kg 4528 lbs	4.0HP

## II. INSTALLATION REQUIREMENT

### A. TOOLS REQUIRED

- ✓ Rotary Hammer Drill ( $\Phi 19$ ,  $\Phi 10$ ,  $\Phi 4$ ,)



- ✓ Hammer



- ✓ Level Bar



- ✓ English Spanner (12")



- ✓ Ratchet Spanner With Socket (28#)



- ✓ Wrench Set (8#, 14#, 15#, 17#, 19#)



- ✓ Carpenter's Chalk



- ✓ Screw Sets



- ✓ Tape Measure (7.5m)



- ✓ Pliers



- ✓ Lock Wrench



- ✓ Grease gun



Fig. 3

## B. SPECIFICATIONS OF CONCRETE

**Specifications of concrete must be adhered to the specification as following. Failure to do so may result in lift and/or vehicle falling.**

1. Concrete must be thickness 100mm minimum and without reinforcing steel bars, and must be dried completely before the installation.
2. Concrete must be in good condition and must be of test strength 3,000psi (210kg/cm<sup>2</sup>) minimum.
3. Floors must be level and no cracks.

## C. POWER SUPPLY

The electrical source must be 3Kw minimum. The source cable size must be 2.5mm<sup>2</sup> and in good condition of contacting with floor.

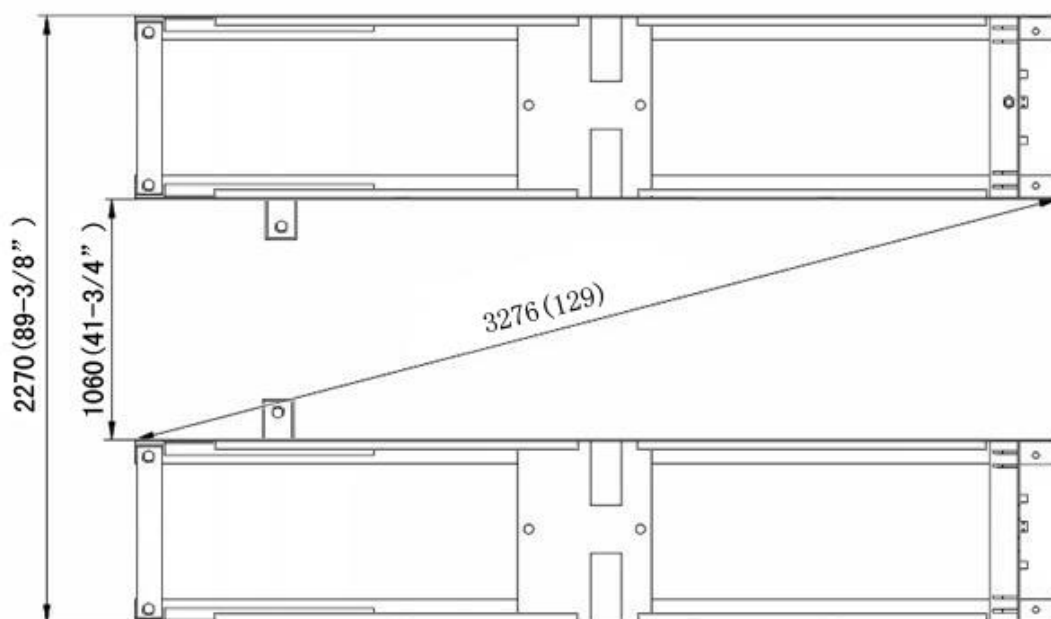
## III. STEPS OF INSTALLATION

### A. Location of Installation

Check and insure the installation location (concrete, layout, space size etc.) is suitable for lift installation.

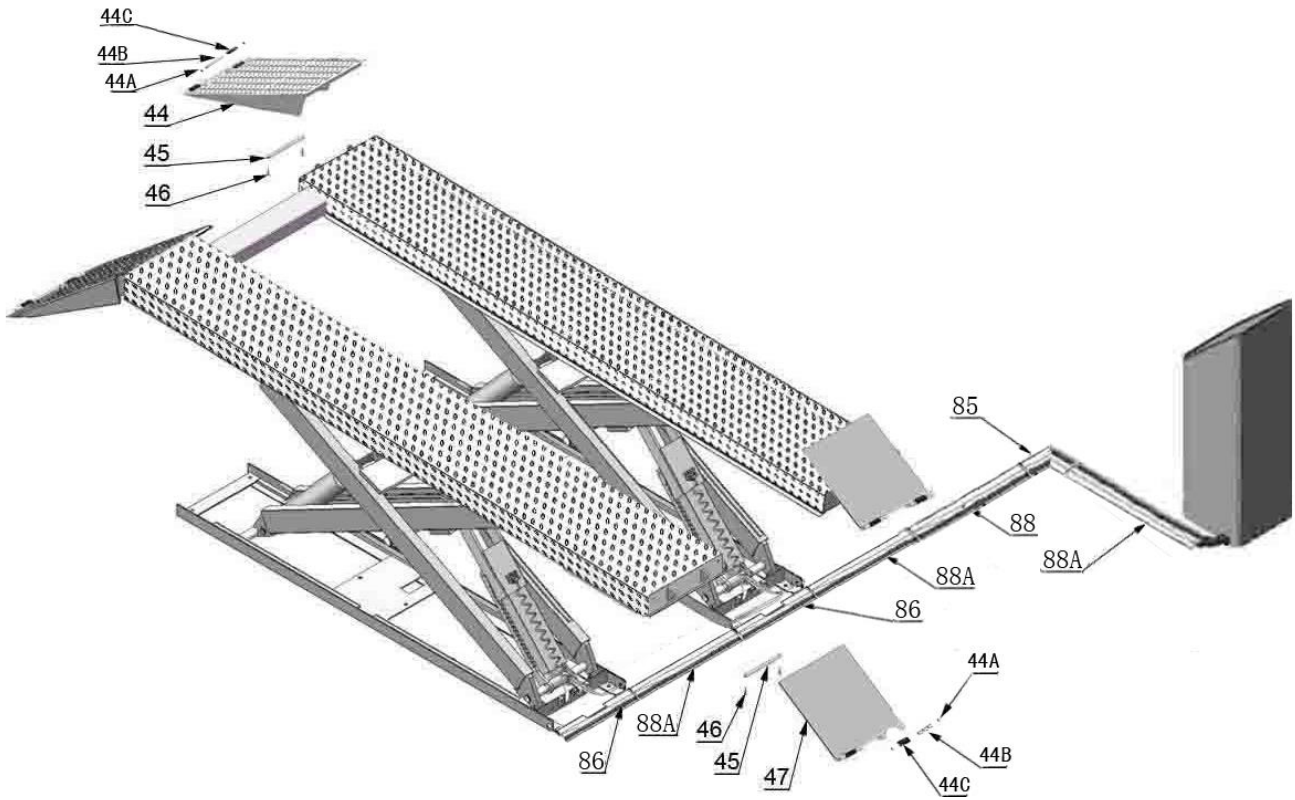
### 1. For Standard Installation: On surface installation

- 1.1 TLX12/TLX12A(X550/X550A) On surface installation foundation (**See Fig. 4**).



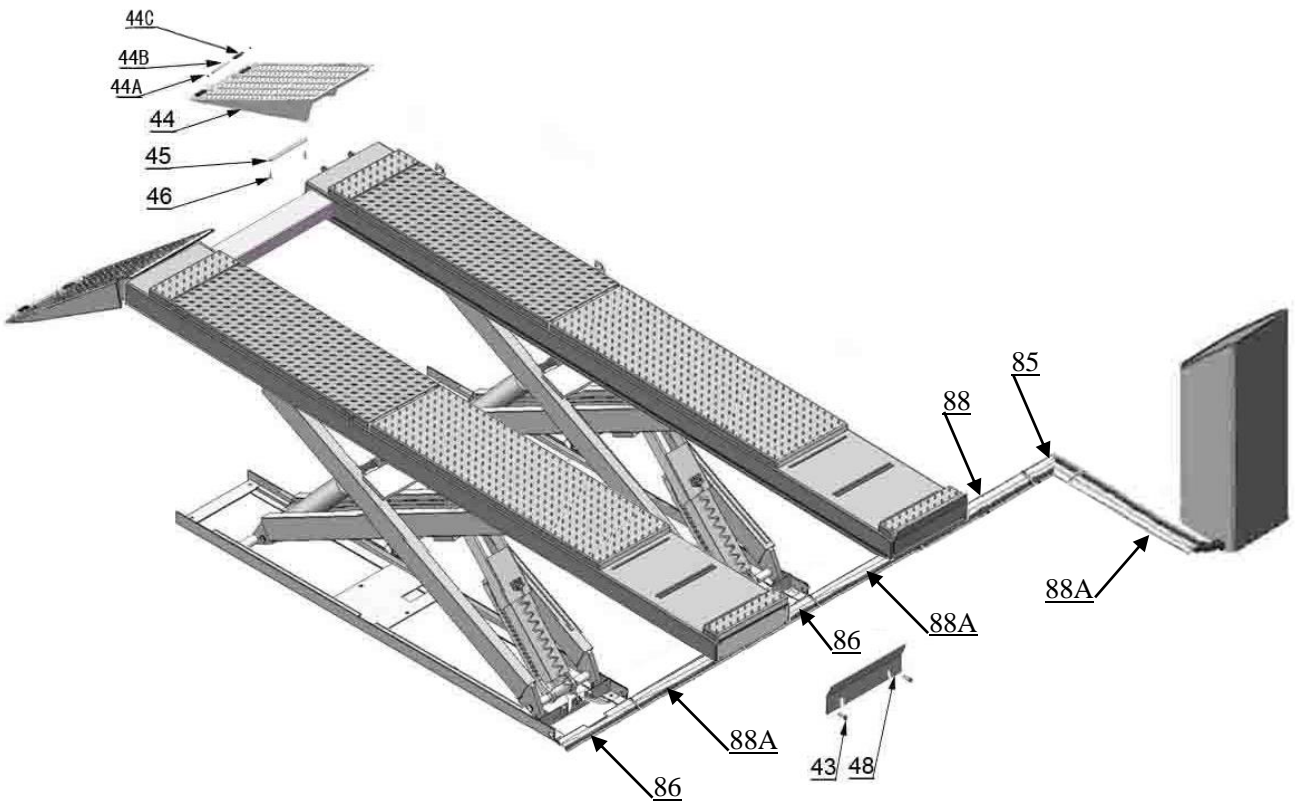
**Fig. 4**

1.2 Illustration of scissors lift **TLX12** on surface installation (See Fig.5).



**Fig. 5**

1.3 Illustration of scissors lift **TLX12A** on surface installation (See Fig.6).



**Fig. 6**



## 2. For Optional Installation: Flush mount installation

### 2.1 Flush mount installation foundation (Fig.7).

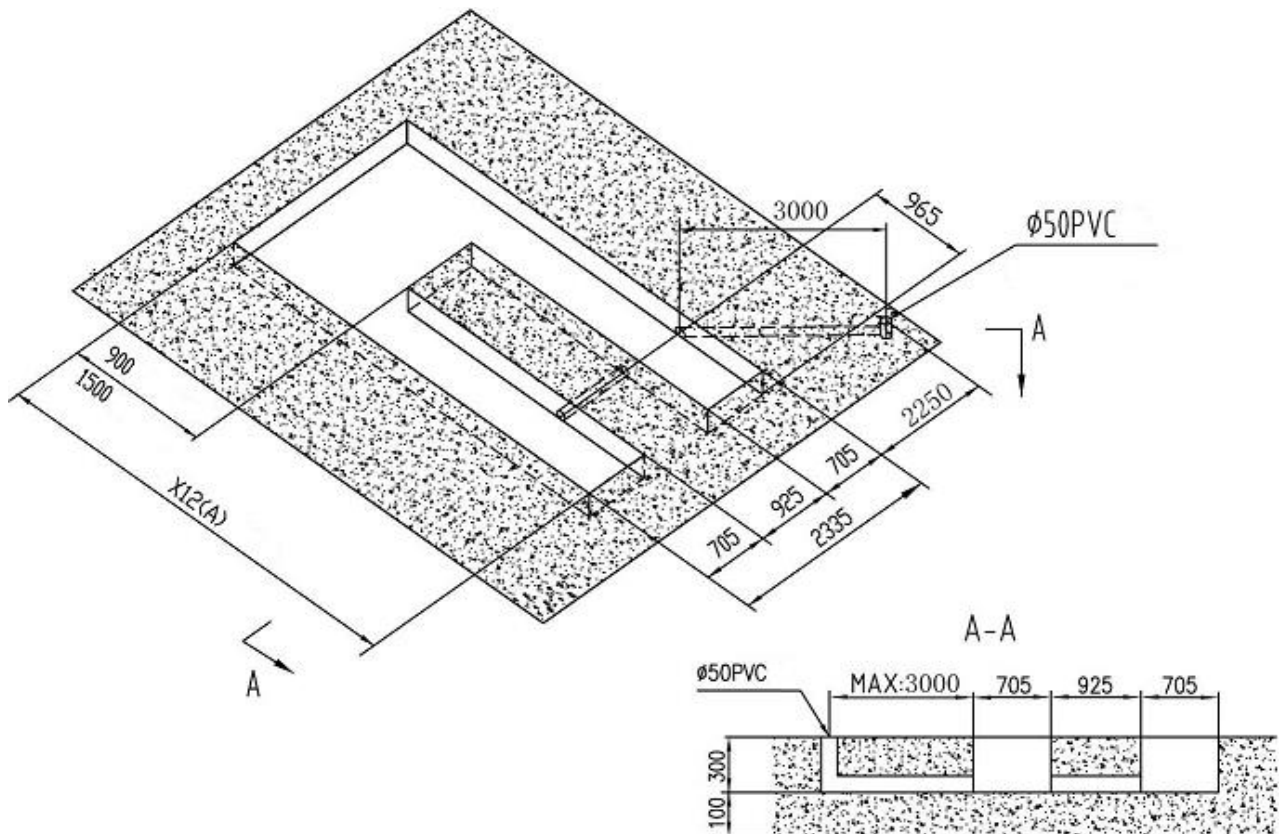


Fig. 7

### 2.2 Illustration of scissors lift TLX12(X550) with flush mount installation (Fig.8).

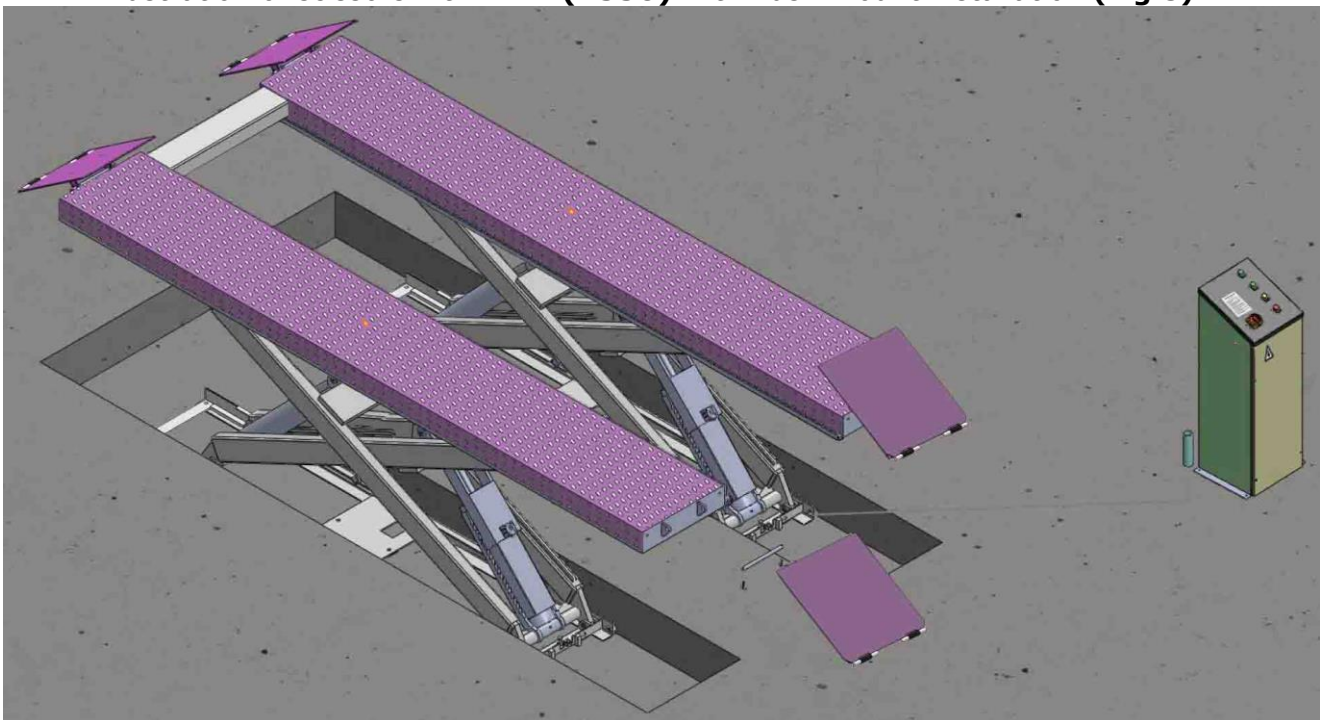
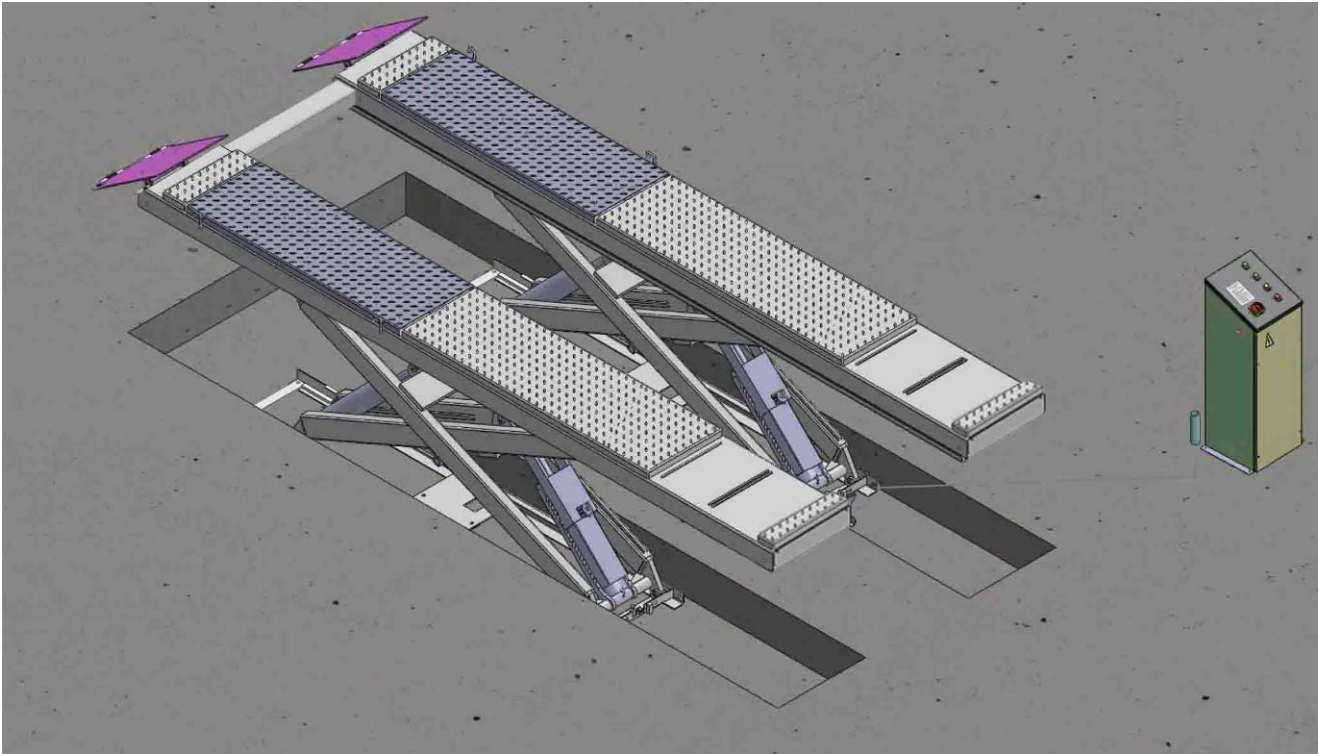


Fig. 8



2.3 Illustration of scissors lift **TLX12A** with flush mount installation (**Fig.9**).



**Fig. 9**

**B. Check the parts before assembly.**

1. Packaged lift and control cabinet (**See Fig. 10**).

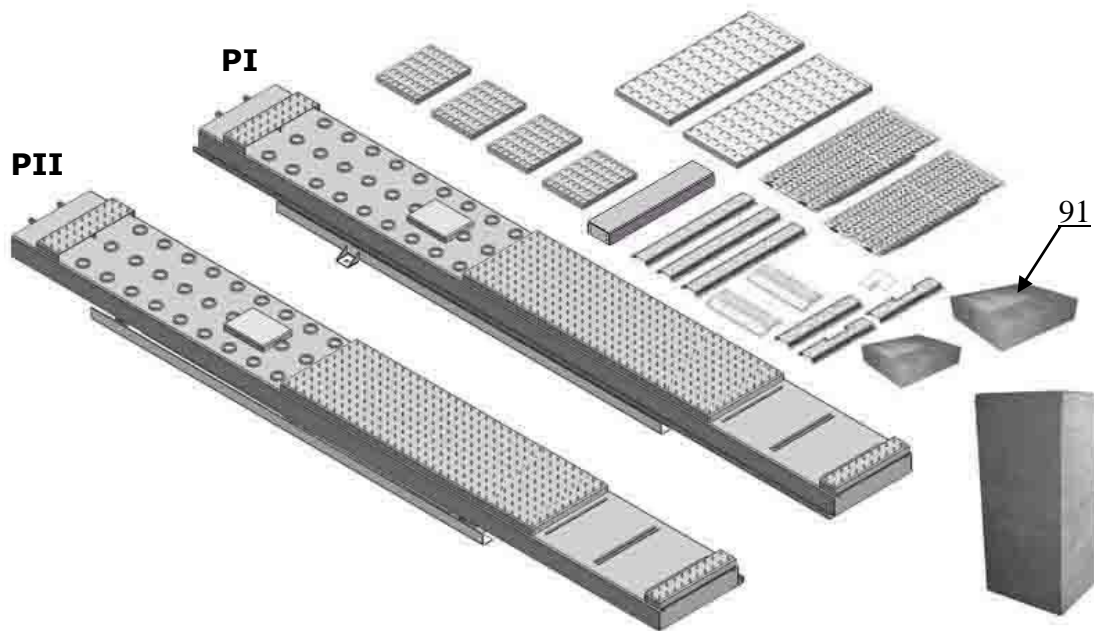


**Fig. 10**

2. Move aside the lift with fork lift or hoist, and open the outer packing carefully.

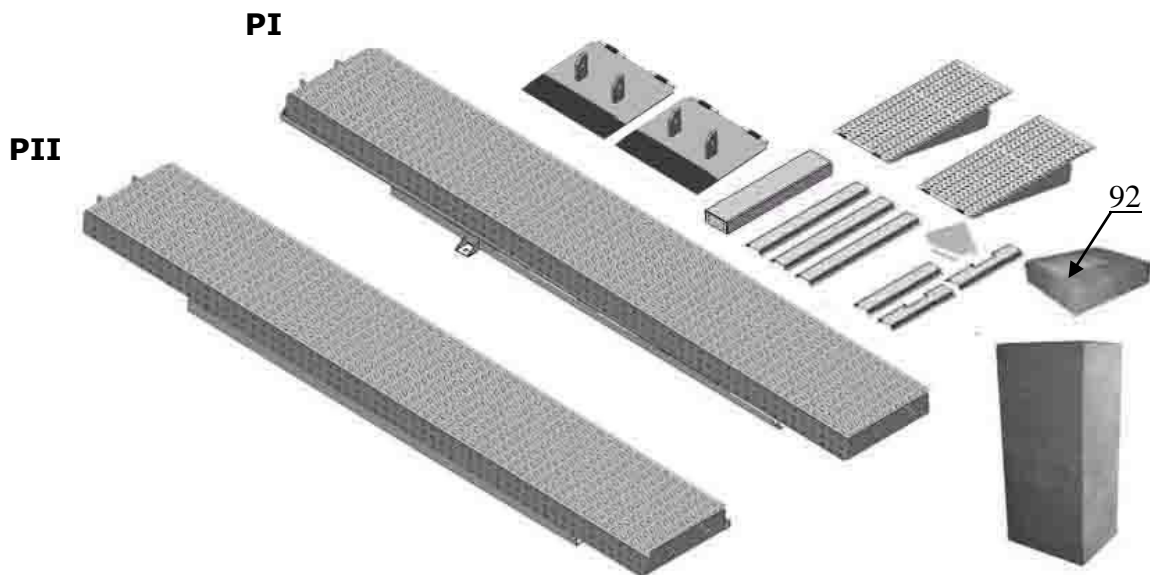
2.1 Parts for on surface installation (See Fig.11, Fig.12)

**For Model TLX12A**



**Fig. 11**

**For Model TLX12**



**Fig. 12**

## 2.2 Parts for flush mount installation (See Fig.13, Fig.14)

Noted: Need guide ramp for flush mount installation

### For Model TLX12A

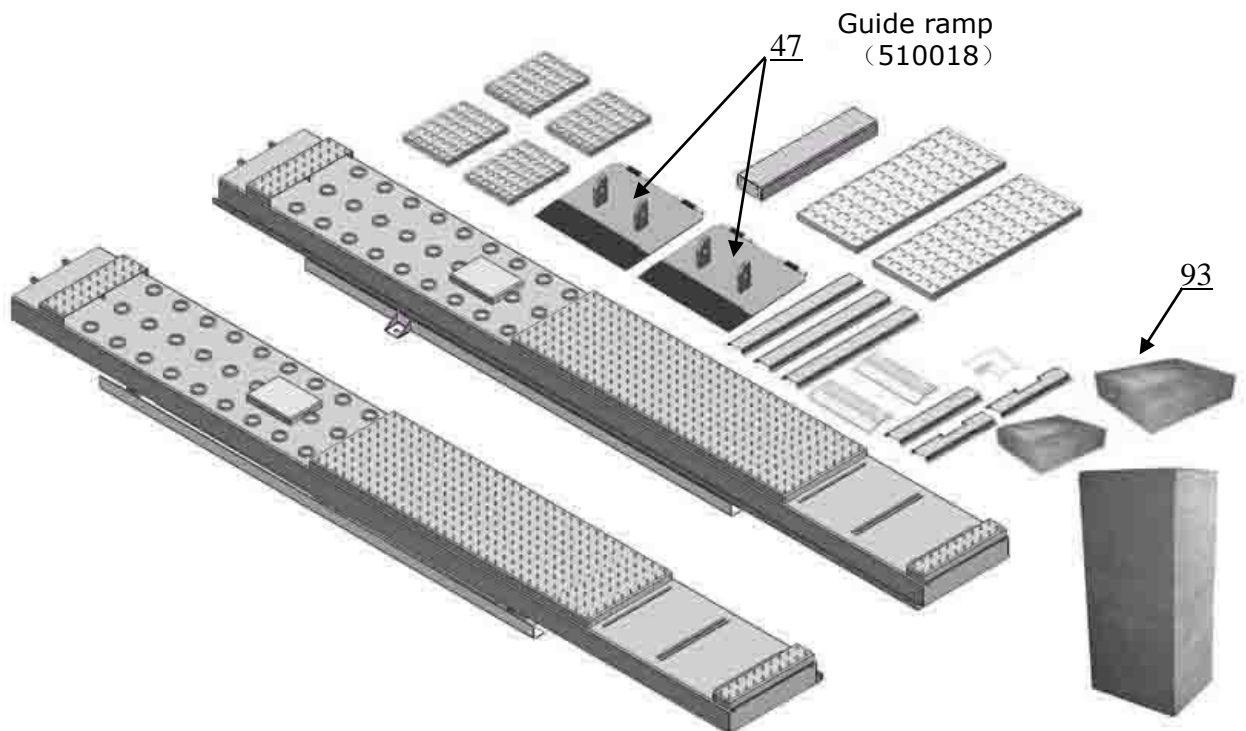


Fig. 13

### For Model TLX12

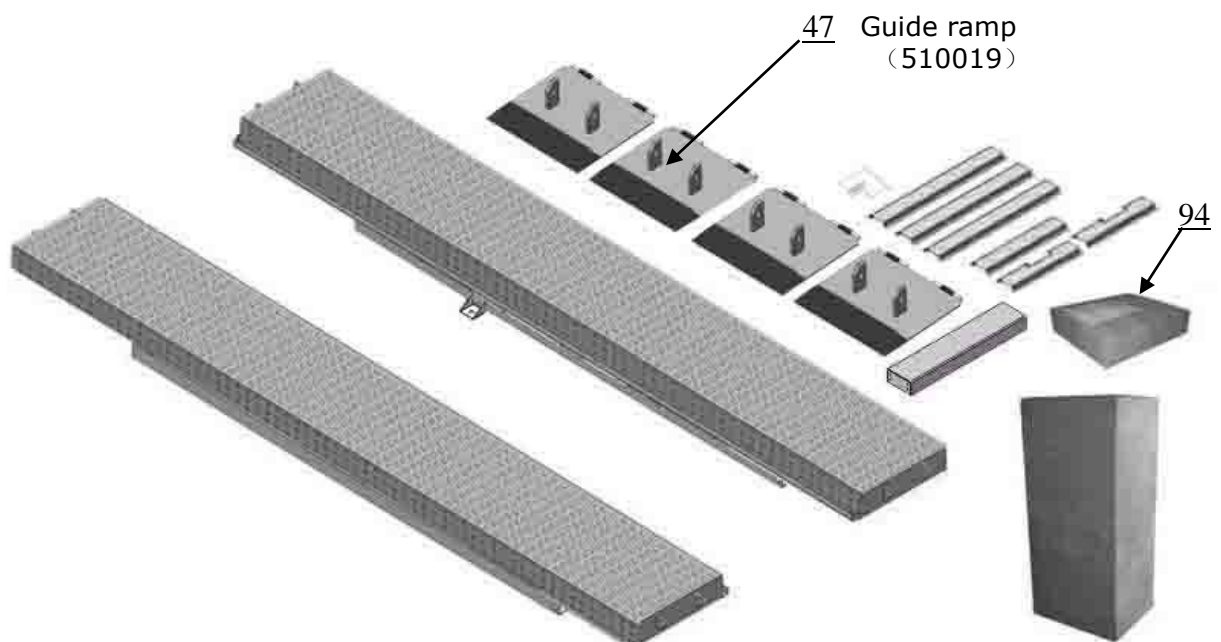


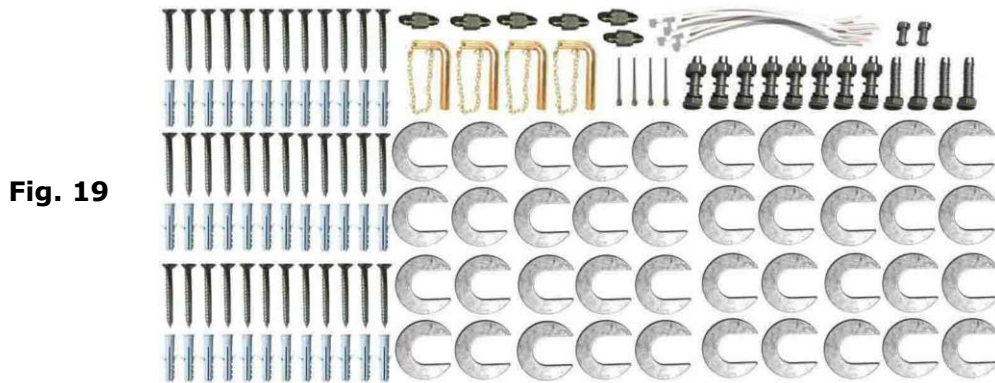
Fig. 14





4.2 Parts bag for flush mount installation (See Fig.19, Fig.20)

**For TLX12A**



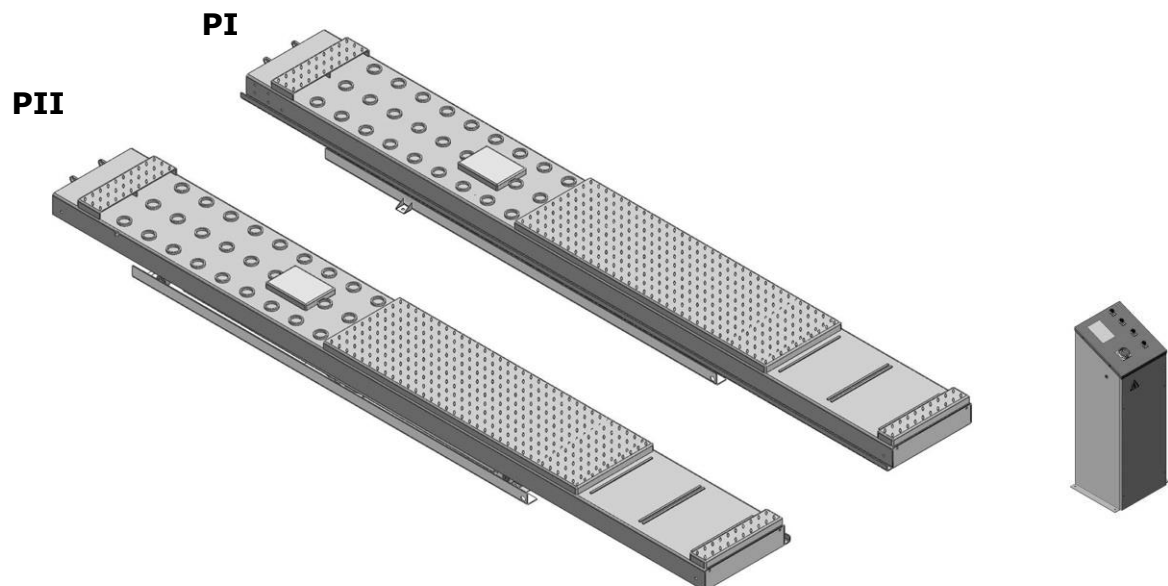
**For TLX12**



**C. Layout the machine and install oil system and air line system.**

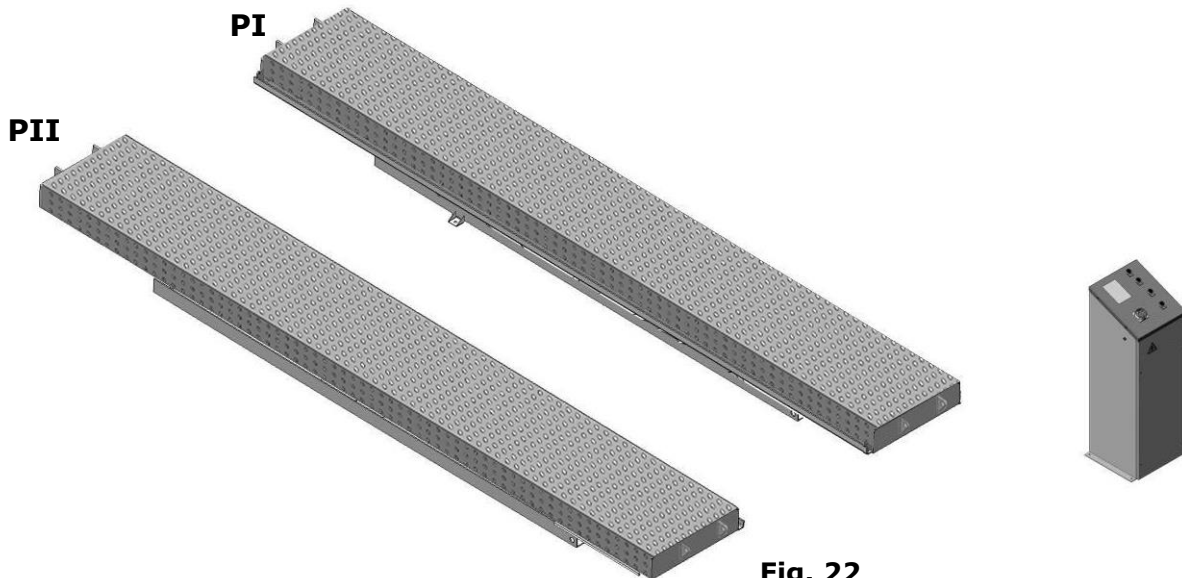
1. Select a location and layout the equipment according to steps **A** (See Fig. 21-22).  
The control cabinet can be installed on the left or right according to the site.

**For Model TLX12A**



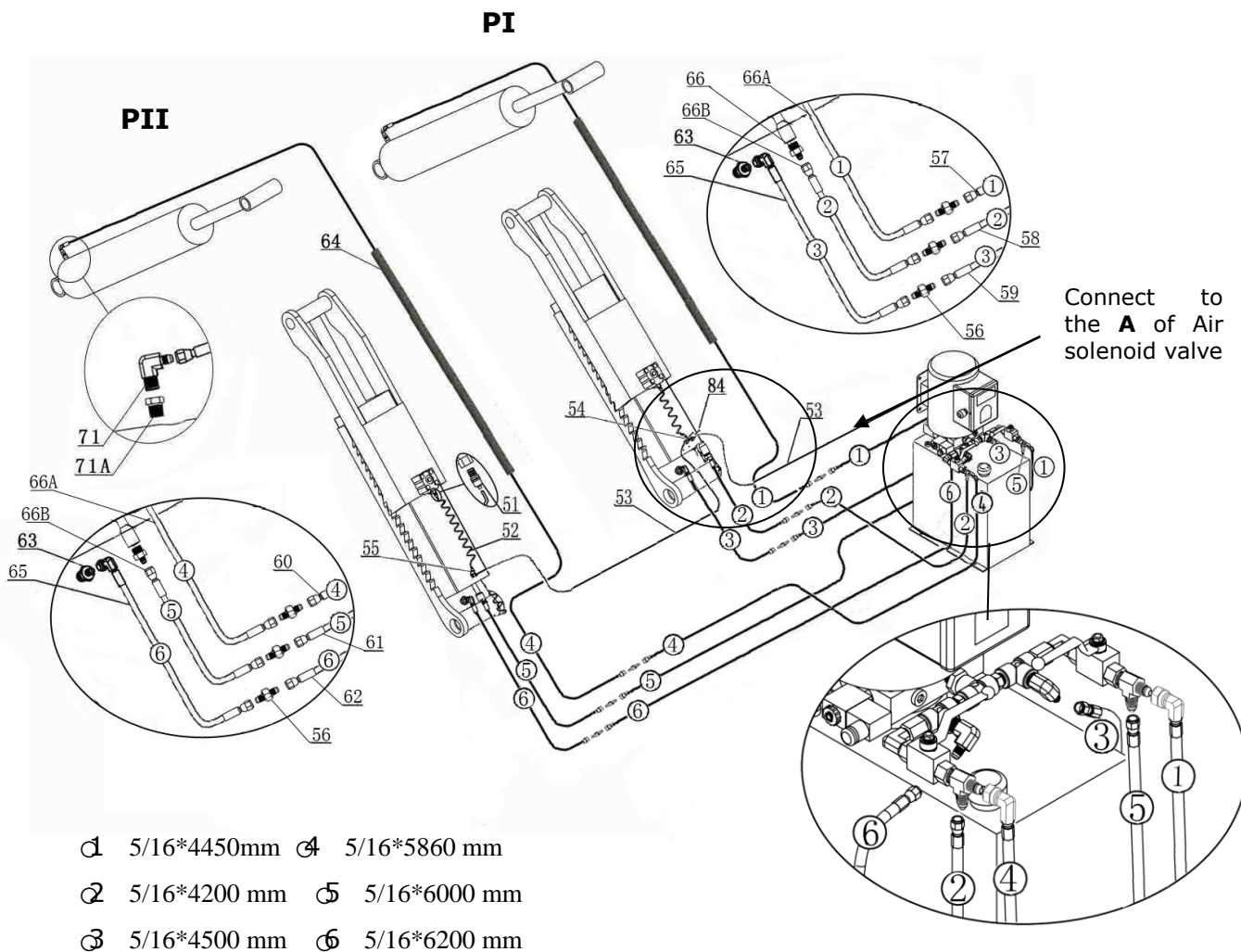


For Model TLX12

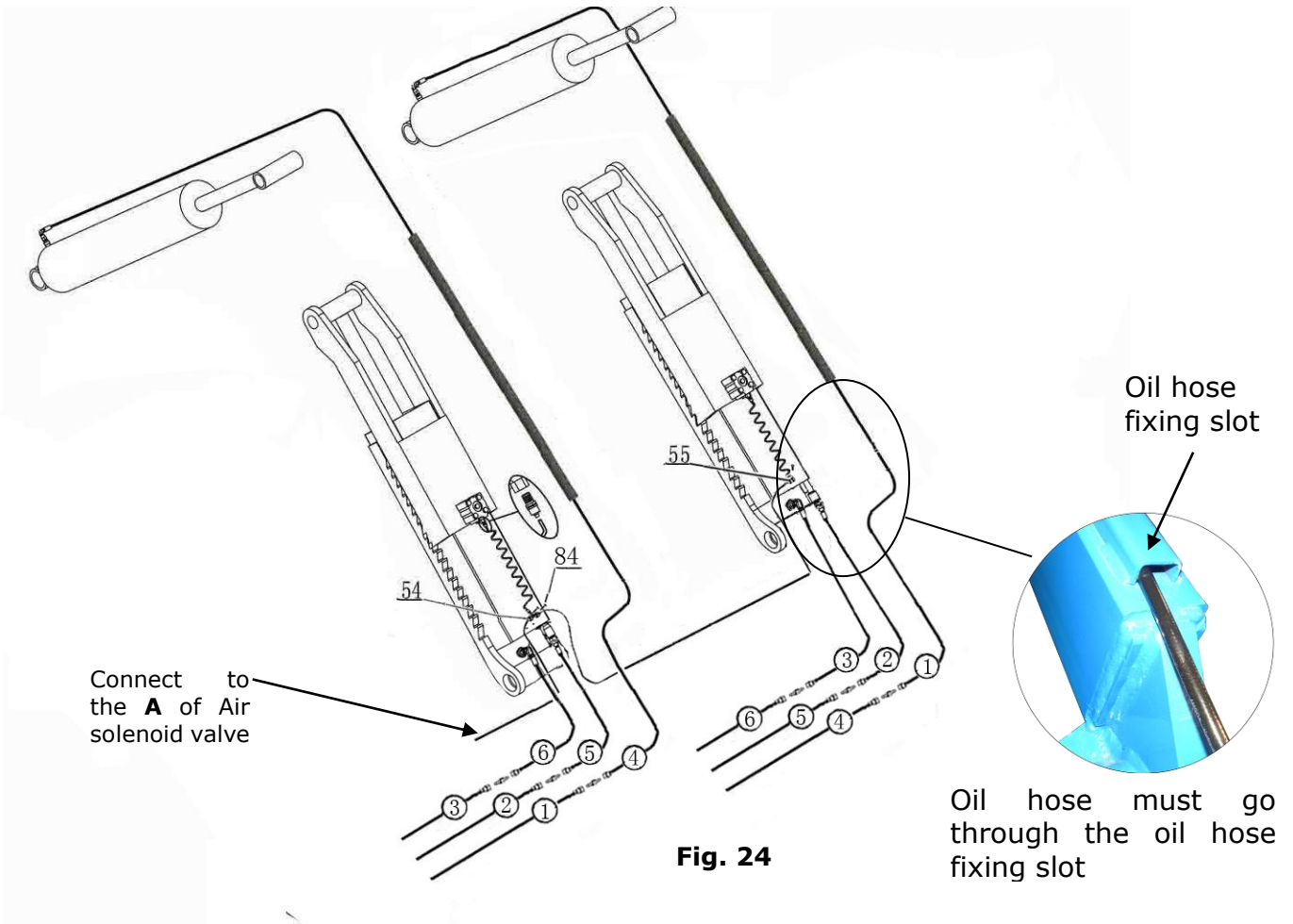


2. Connecting the oil hose and air line.

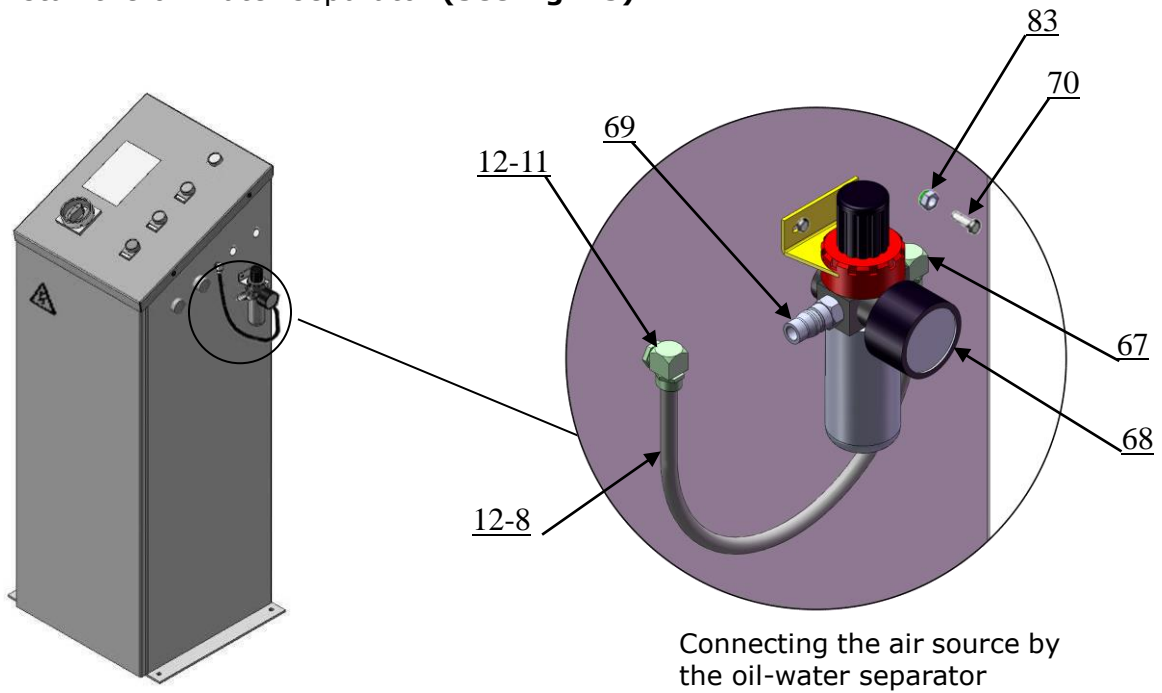
2.1 Control cabinet installed in the left of the car in direction (See Fig. 23).



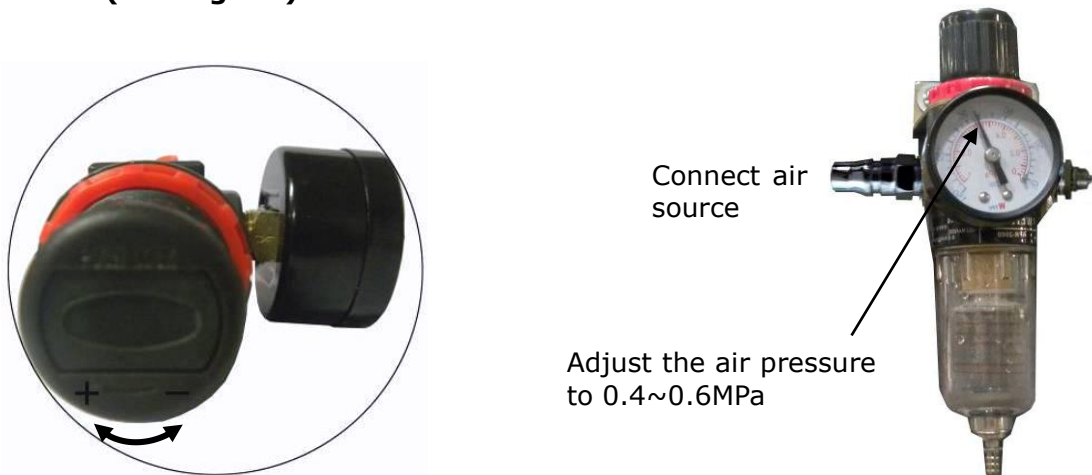
2.2 Control cabinet installed in the right of the car in direction (See Fig. 24).



3. Install the oil-water separator (See Fig. 25).



4. Connect the air source (air pressure 5kg/cm<sup>2</sup>-8kg/cm<sup>2</sup> ), Adjust the air pressure to 0.4~0.6MPa (See Fig. 26).



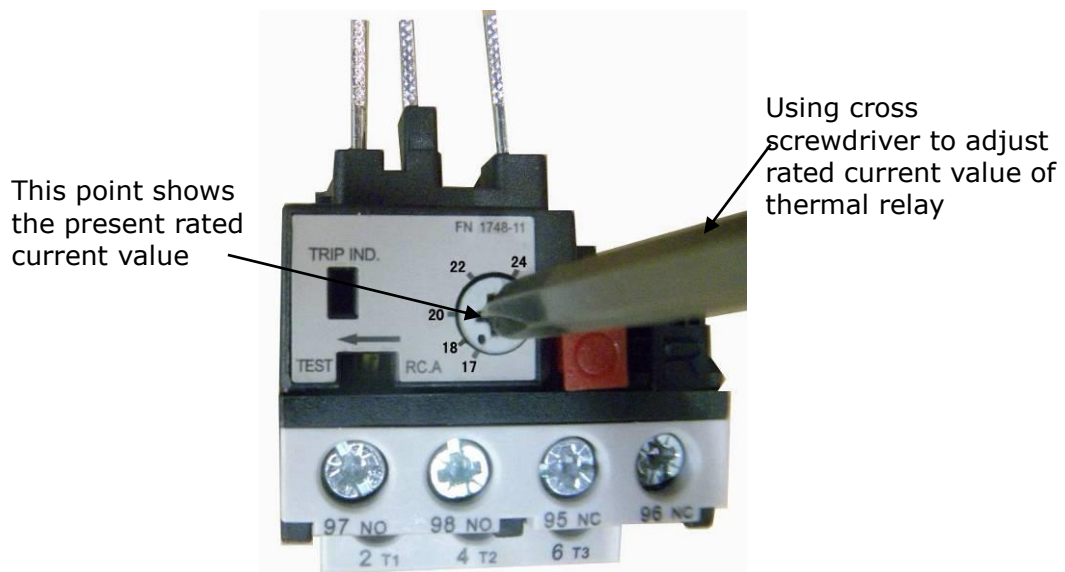
Clockwise to increase the air pressure  
Counter-clockwise to reduce the air pressure  
Adjust the air pressure to 0.4~0.6MPa

**Fig. 26**

#### D. Install electric system

1. Adjusting the current rating of thermal relay in control box according to the different configurations of hydraulic power unit. In general, the electric current of thermal relay should equal or larger than that of motor. The following table shows rated current regulation of thermal relay in case of different hydraulic power unit.

Hydraulic power unit	Single phase /4.0HP	Three phase /4.0HP
Rated current of thermal relay	22A	14A



**Fig. 27**

## 2. Wire connection for hydraulic power unit (380V)

2.1 Connect the power wire and limit switch wire according to the Wiring diagram (See Fig. 28).

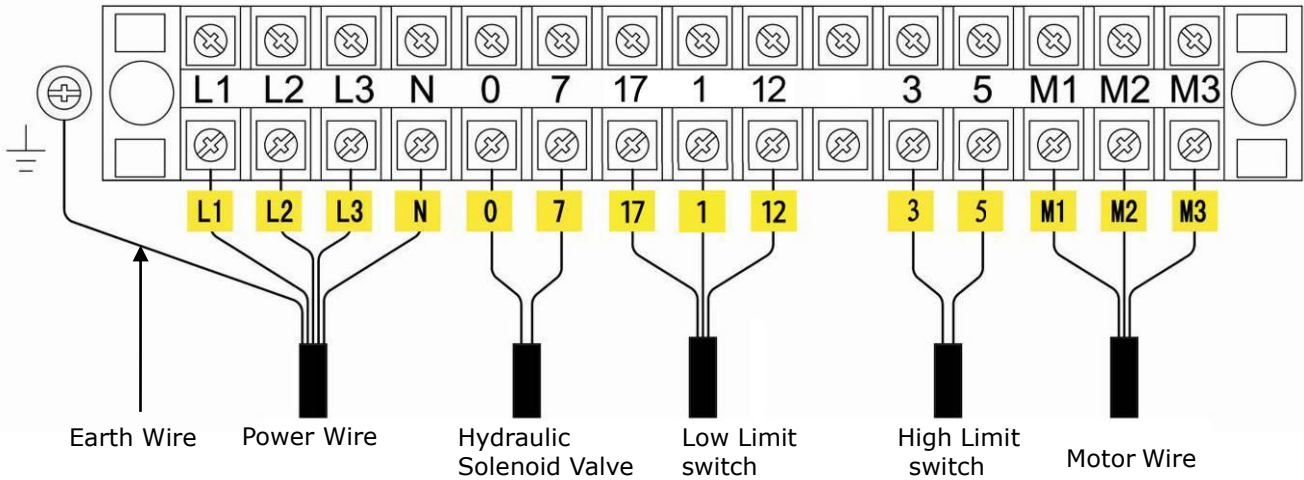


Fig. 28

2.2 Circuit Diagram (See Fig. 29).

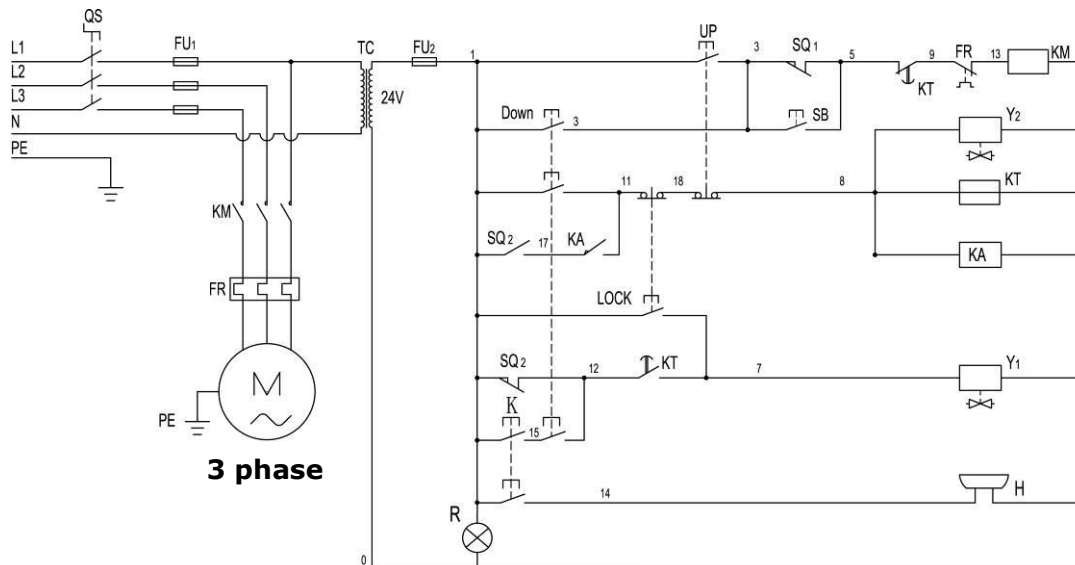


Fig. 29

### Electric Component

Item	Name	Code	Specification	Item	Name	Code	Specification
1	Power switch	QS	380V AC	11	Push button	LOCK	Duplex
2	Fuse	FU1	25A	12	Push button	DOWN	Triple
3	Fuse	FU2	3A	13	Lower alarm button	K	Duplex
4	AC contactor	KM	24V AC	14	Motor	M	Three phase
5	Thermal relay	FR	17A-24A	15	Buzzer	H	24V AC
6	Time relay	KT	24V AC	16	Transformer	TC	24V AC
7	Limit Switch	SQ1、SQ2	10A	17	Intermediate relay	KA	24V AC
8	Hydraulic Solenoid Valve	Y1	24V AC	18	Red button	SB	2A
9	Air solenoid Valve	Y2	AC 24V	19	Power indicator	R	24VAC
10	Push button	UP	Duplex				

### 3. Wire connection for hydraulic power unit (220V)

3.1 Connect the power wire and limit switch wire according to the Wiring diagram (See Fig. 30)

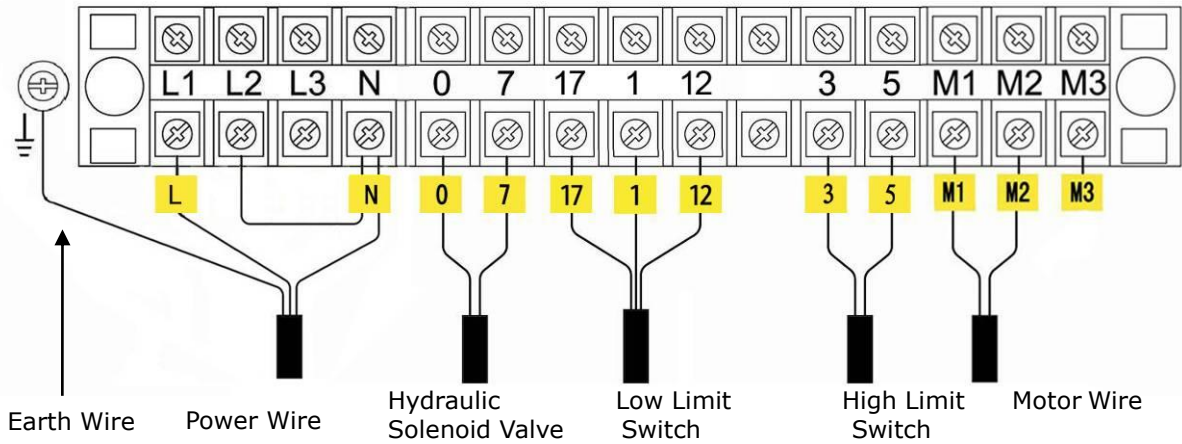


Fig. 30

3.2 Circuit Diagram (See Fig. 31).

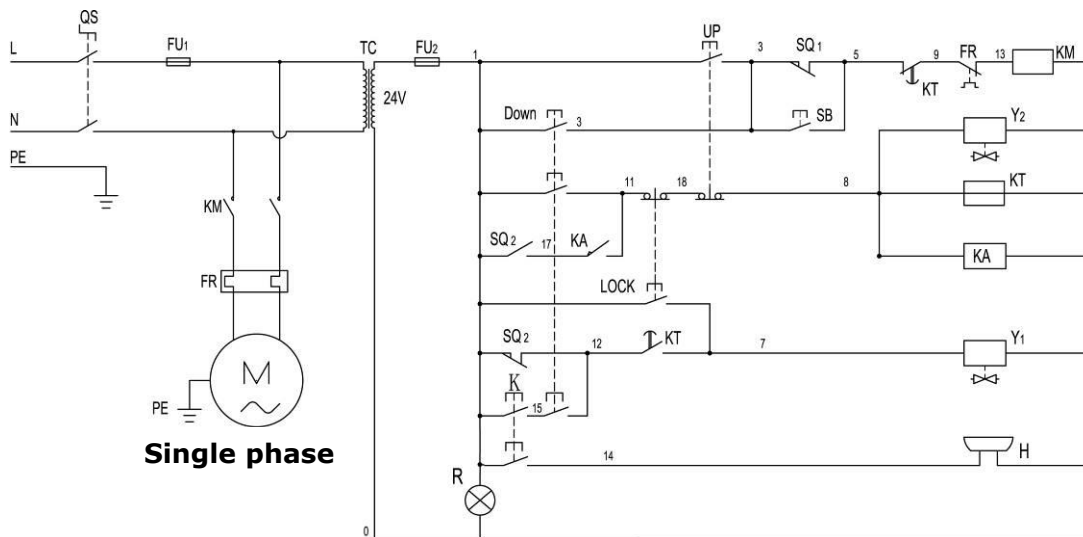


Fig. 31

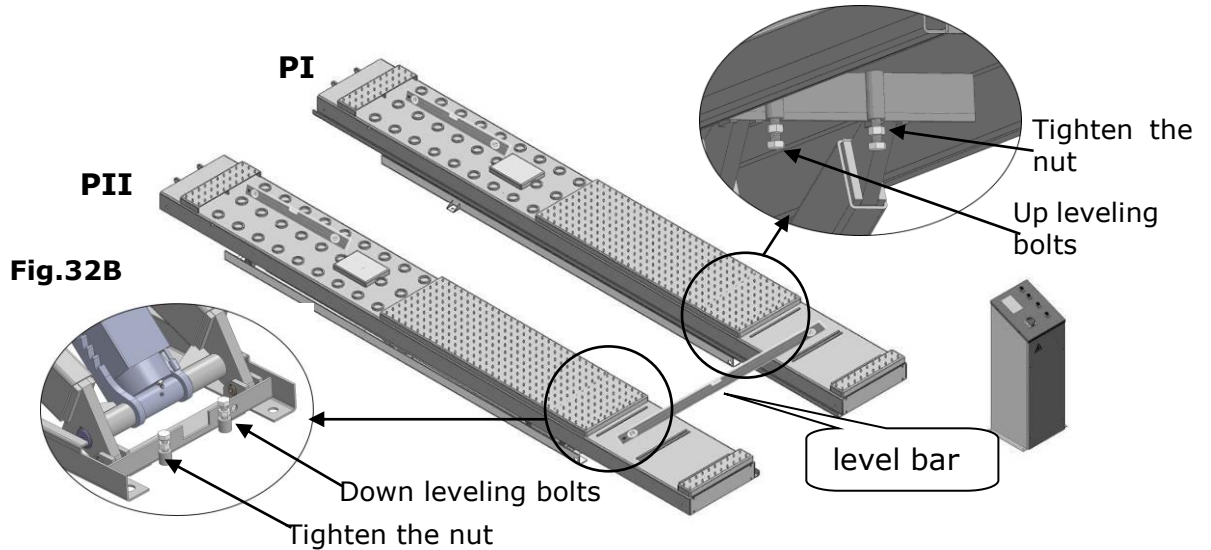
#### Electric Component

Item	Name	Code	Specification	Item	Name	Code	Specification
1	Power switch	QS	380V AC	11	Push button	LOCK	Duplex
2	Fuse	FU1	25A	12	Push button	Down	Triple
3	Fuse	FU2	3A	13	Lower alarm button	K	Duplex
4	AC contactor	KM	24V AC	14	Motor	M	Single phase
5	Thermal relay	FR	17A-24A	15	Buzzer	H	24VAC
6	Time relay	KT	24V AC	16	Transformer	TC	24VAC
7	Limit Switch	SQ1、SQ2	10A	17	Intermediate relay	KA	24VAC
8	Hydraulic solenoid valve	Y1	24V AC	18	Red button	SB	2A
9	Air solenoid valve	Y2	AC 24V	19	Power indicator	R	24VAC
10	Push button	UP	Duplex				



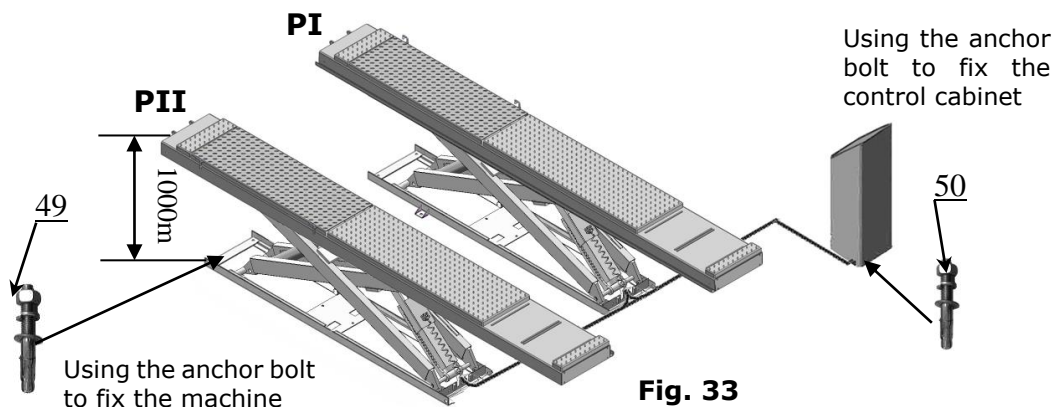
## E. Level two platforms and install anchor bolts.

1. Check by level bar, adjust the down leveling bolts(see **fig.32B**) and add the shim until two platforms are in the same level, lowering the lift to the lowest position and adjust the up leveling bolts (**see fig.32A**) until contacting the down leveling bolts, tighten the nut with wrench.



2. Install anchor bolts.

- 2.1 Raise the lift to 1000mm then drill holes to install the anchor bolts (**See Fig.33**).



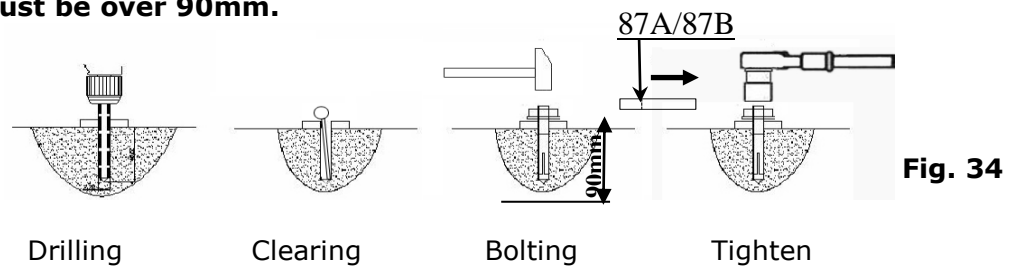
- 2.2 Fix the anchor bolts.

Drilling the hole for the anchor bolt with the rotary hammer drill, type the anchor bolt into the ground, and then fasten it with ratchet spanner (**See Fig. 34**).

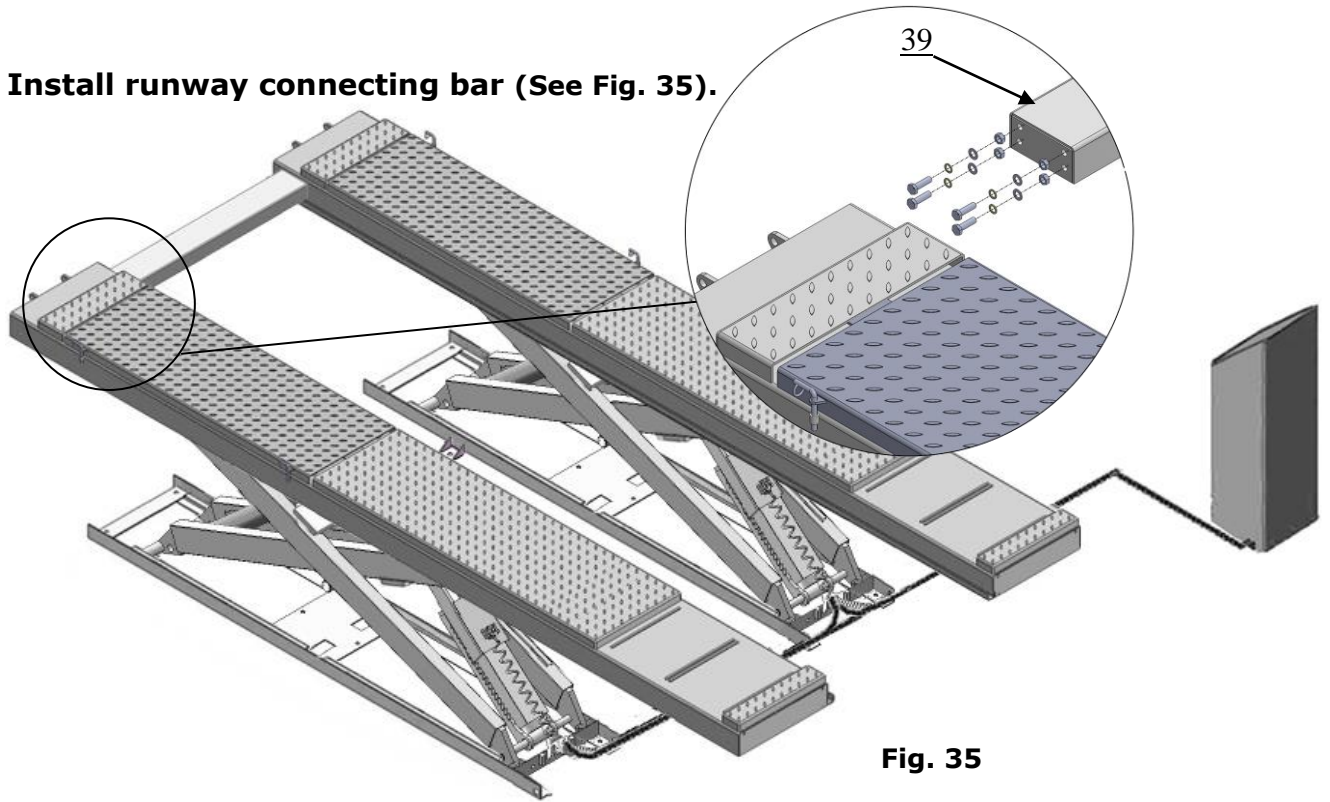
**Note: The twisting force of anchor bolt is 150N.m, the length inside ground of anchor bolt must be over 90mm.**

For the lifts:  
use  $\Phi 19$  driller to drill hole

For the control cabinet:  
use  $\Phi 10$  driller to drill hole



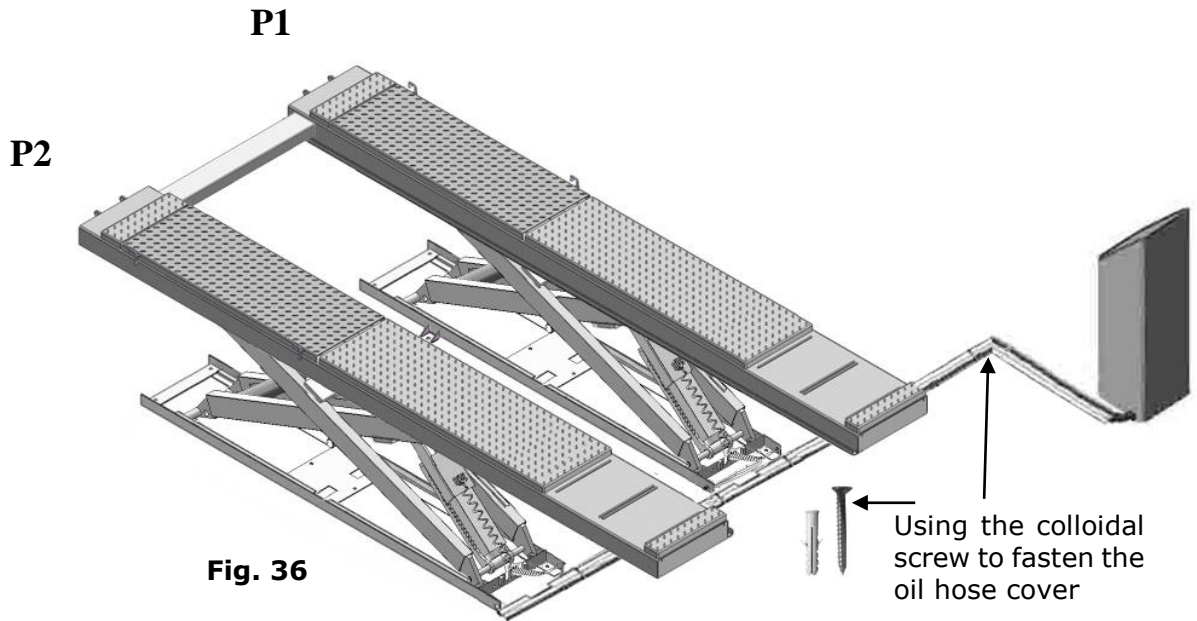
**F. Install runway connecting bar (See Fig. 35).**



**Fig. 35**

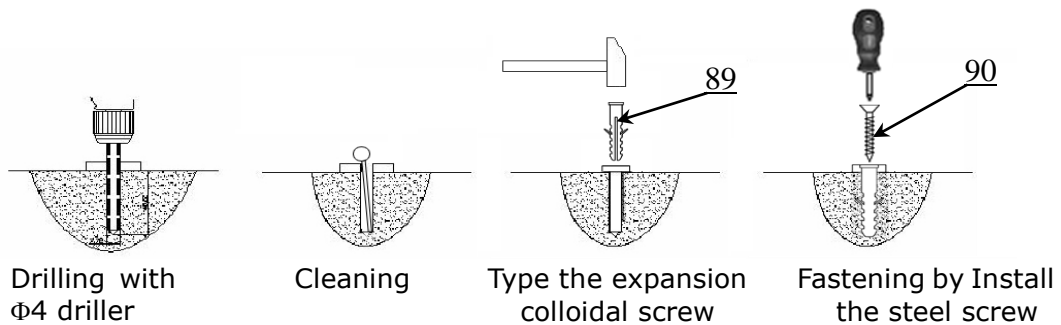
**G. Install oil hose cover for on surface installation.**

1. Tidy up the oil hose and air line, cover the oil hose cover (See Fig. 36).



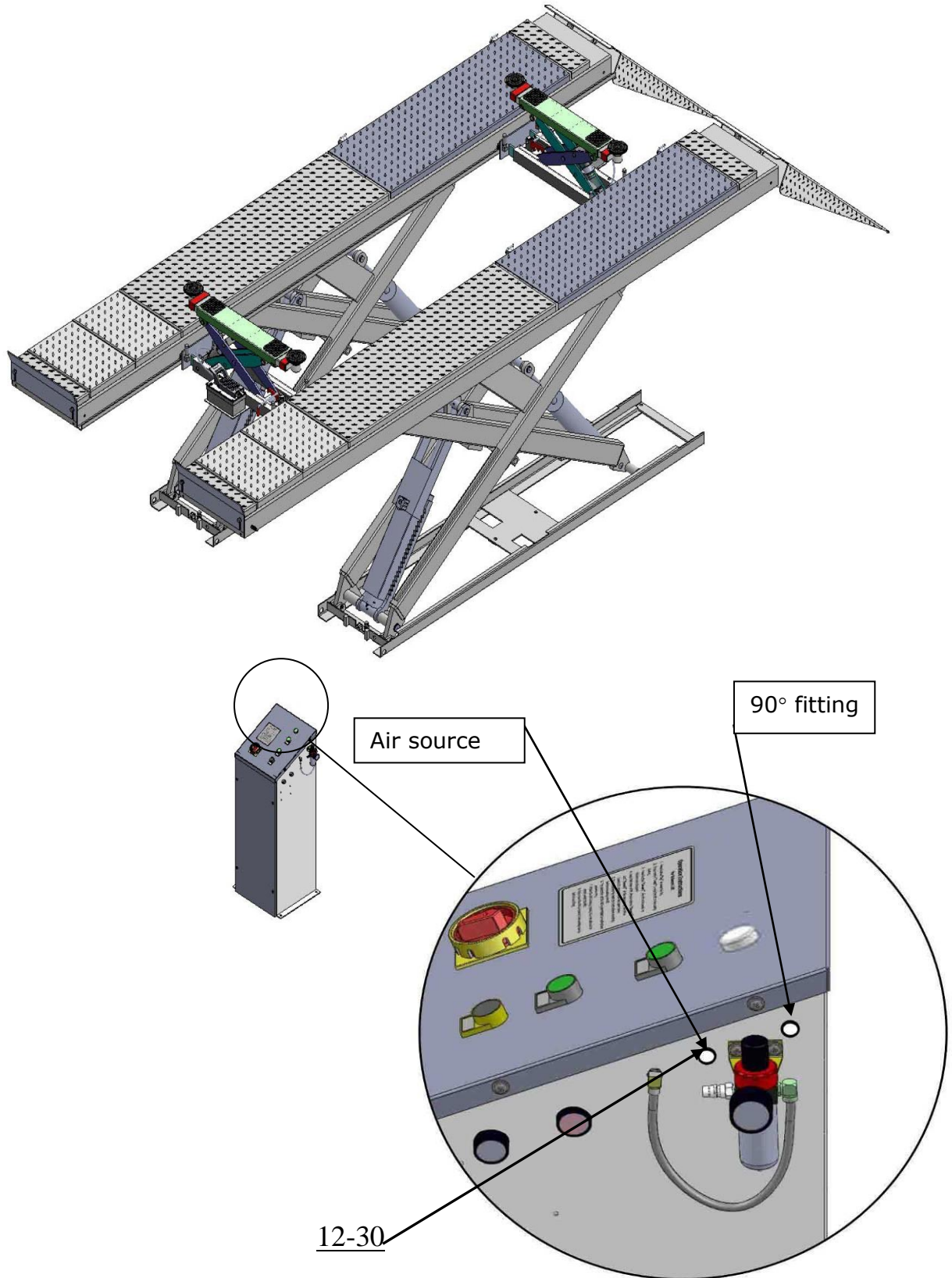
**Fig. 36**

2. Install the oil hose cover (See Fig. 37).



**Fig. 37**

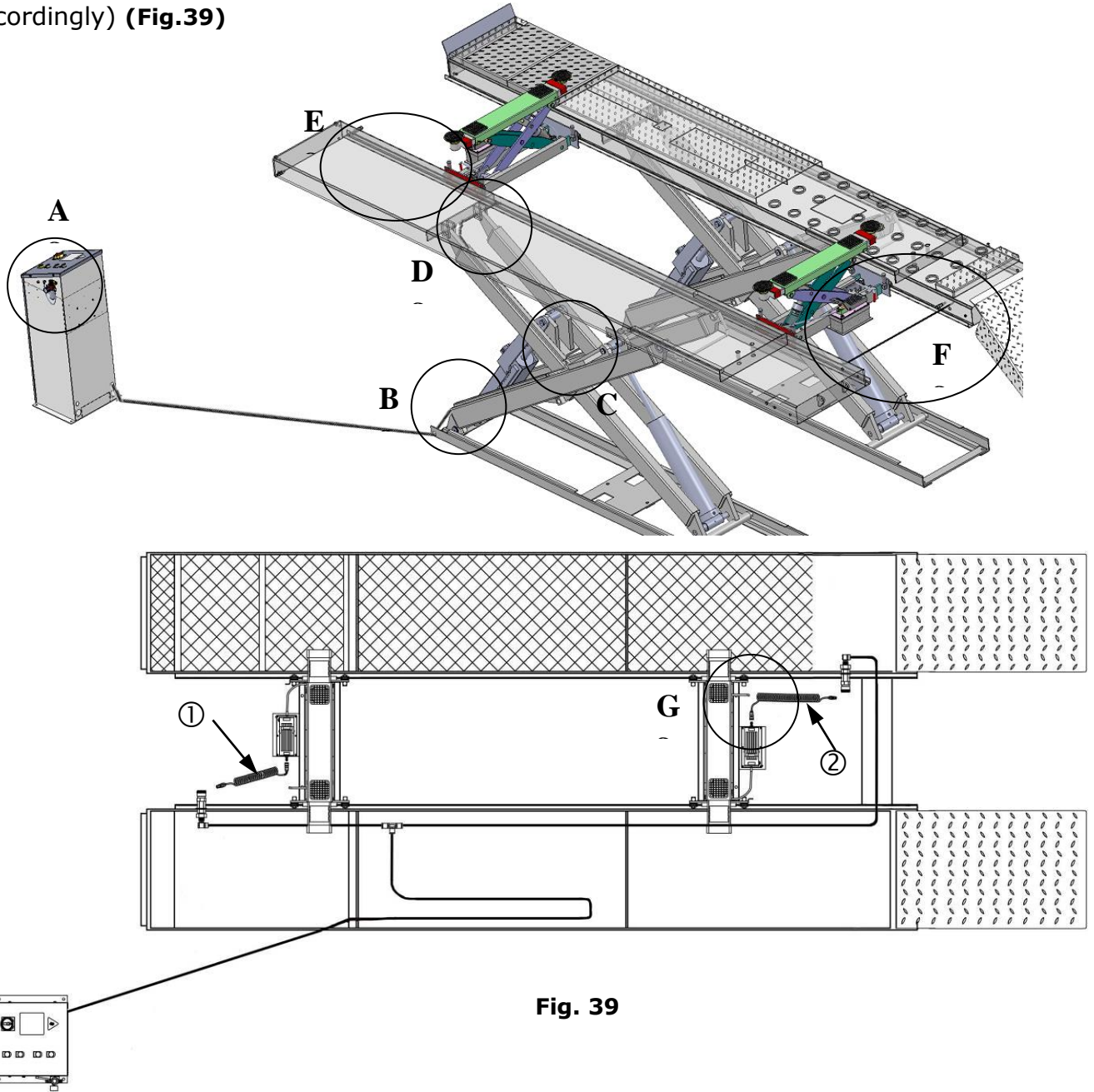
## H. Illustration of installing the TLX12/TLX12A optional air-line kits(Fig.38)



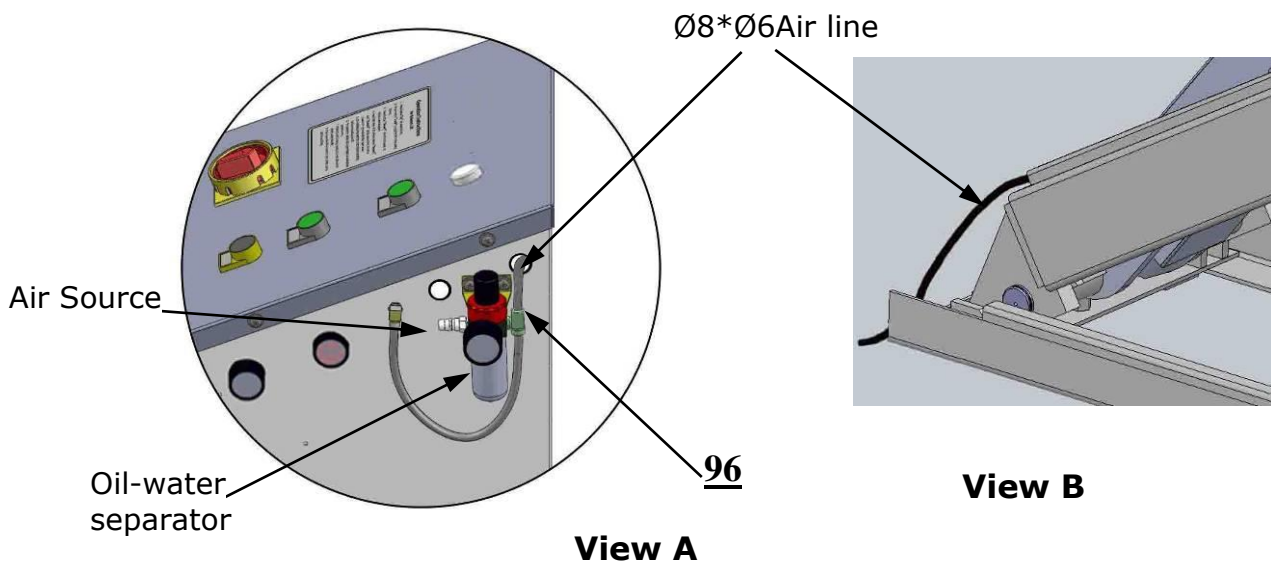
**Fig. 38**



1. Connect the air line fittings with  $\phi 8 * \phi 6$  black air line (The length of air line can be cut accordingly) **(Fig.39)**

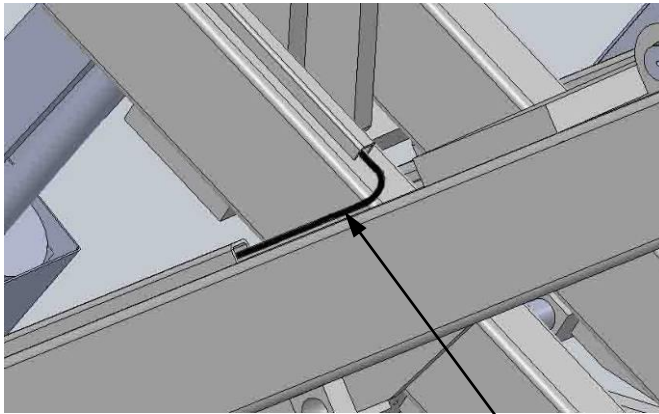


**Fig. 39**

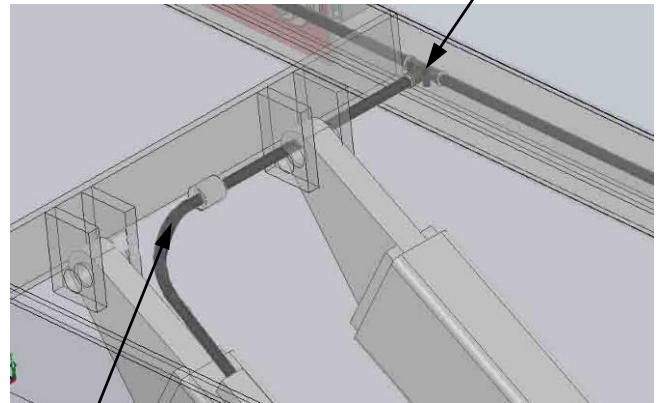


2. First replace the 90° air line fitting on the oil-water separator by the T fitting; Then pass the  $\phi 8*\phi 6$  black air line through control cabinet and connect it to the upper end of T fitting. **(see View A)**

3. Pass the  $\phi 8*\phi 6$  black air line through the hole of base and oil hose fixing slot on the outer scissors. **(see View B,C,D)**



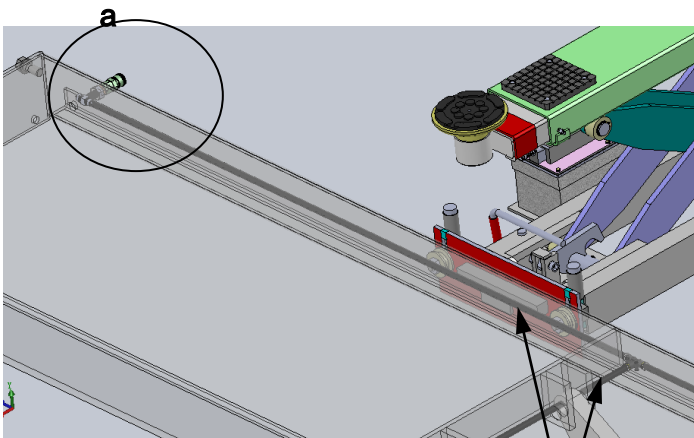
**View C**



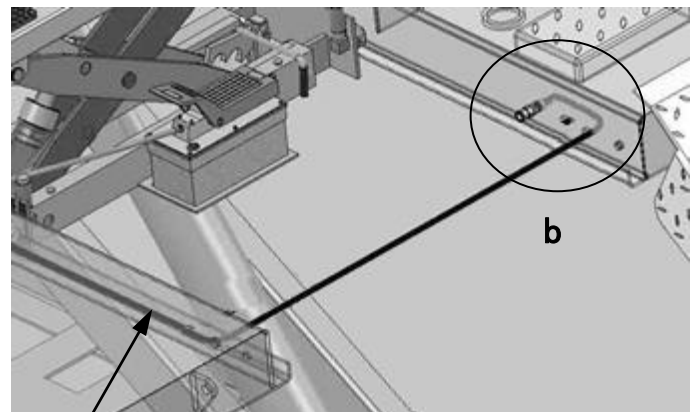
**View D**

$\text{Ø}8*\text{Ø}6$  Air line

4. Divide air into two lines by T- fitting, connect to the rolling jack separately. **(see View E,F)**



**View E**



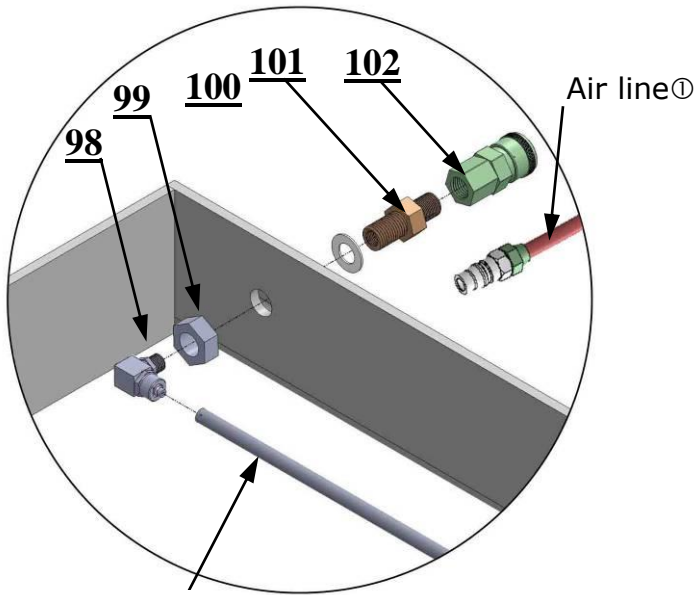
**View F**

$\text{Ø}8*\text{Ø}6$  Air line

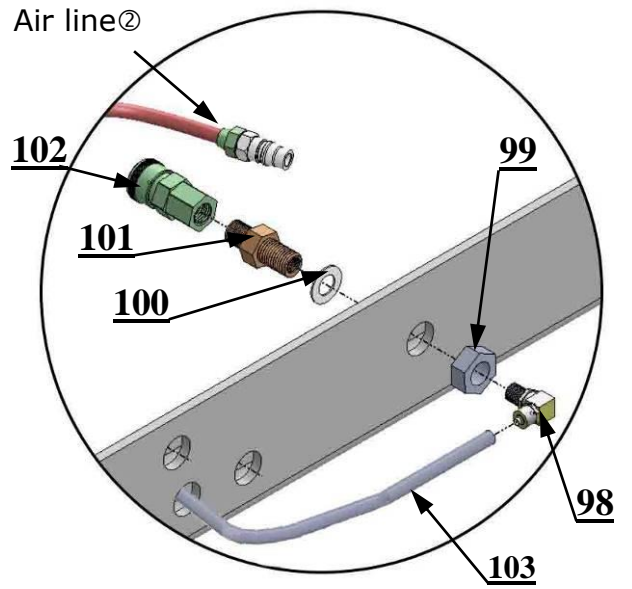
5. Install the C shape female fitting and connect it with male fitting of the air line ① **(see View G)**

6. Install the C shape female fitting and connect it with the male fitting of the air line ② **(see View H)**



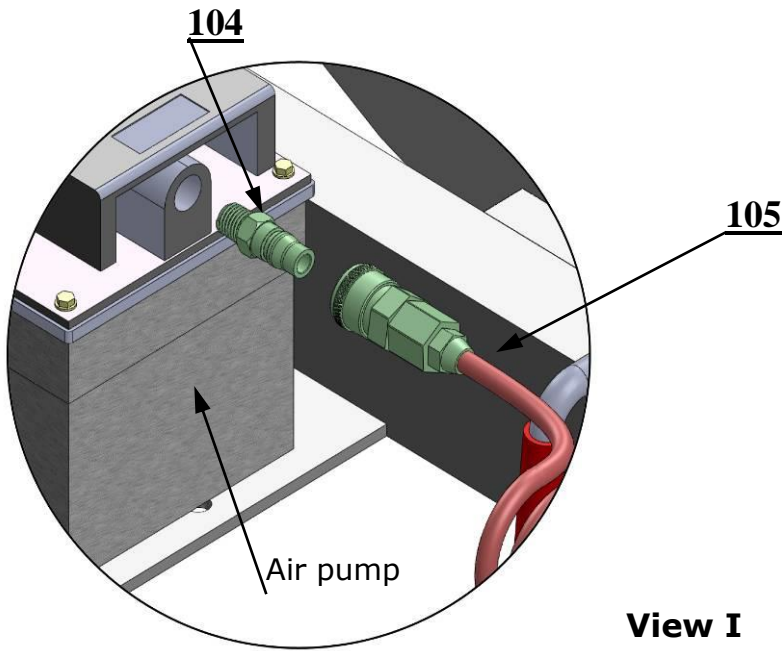


**View G**



**View H**

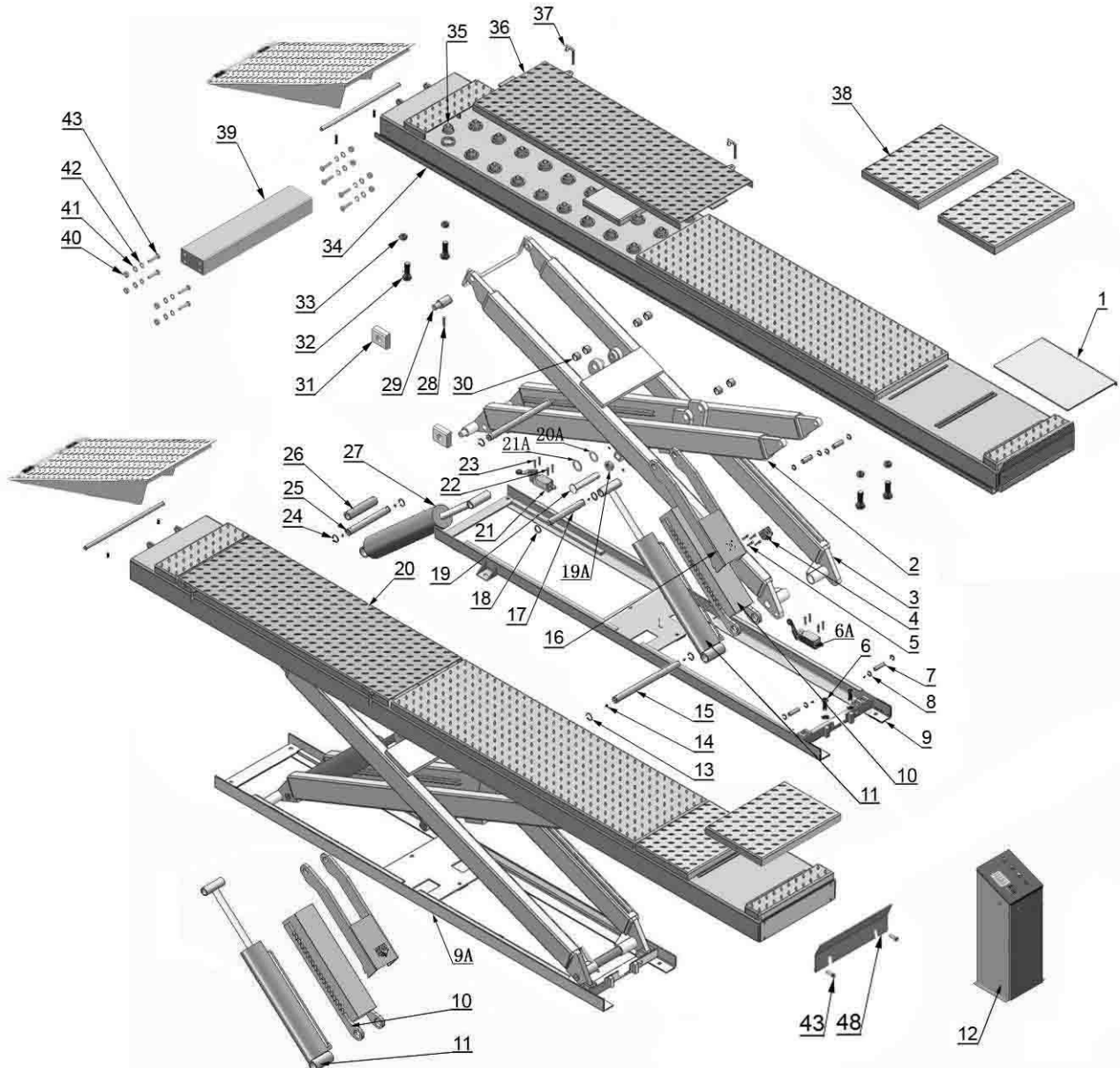
7. Connect the female fitting of air line ① and ② to the male quick fitting on air pump of the two rolling jacks. **(see View I)**



**View I**

# IV. EXPLODED VIEW

## MODEL TLX12A



Optional Turnplate

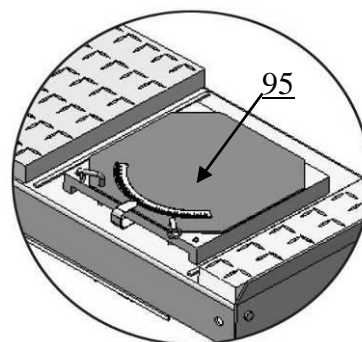
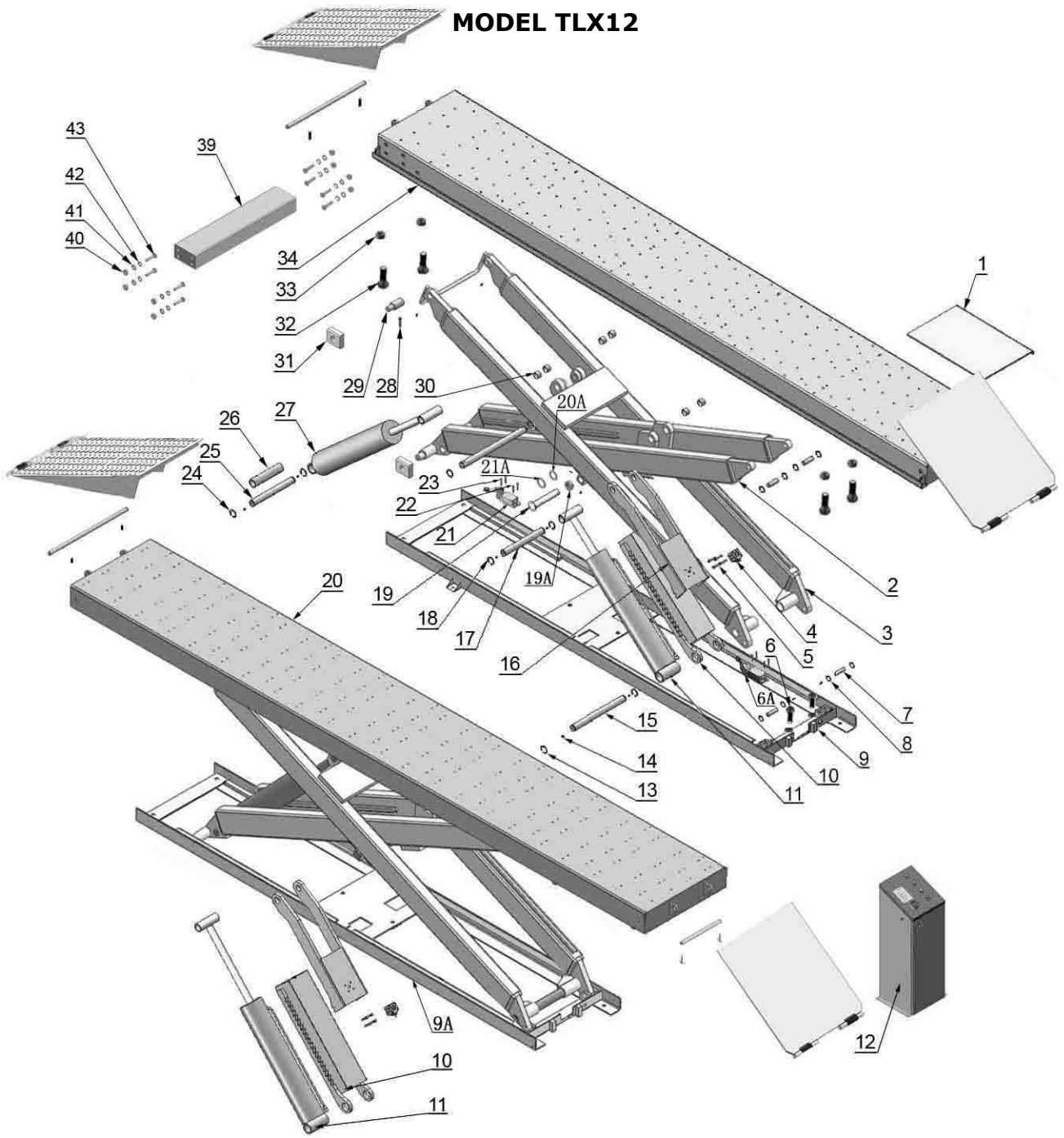


Fig. 40



**Fig. 41**

# CYLINDERS

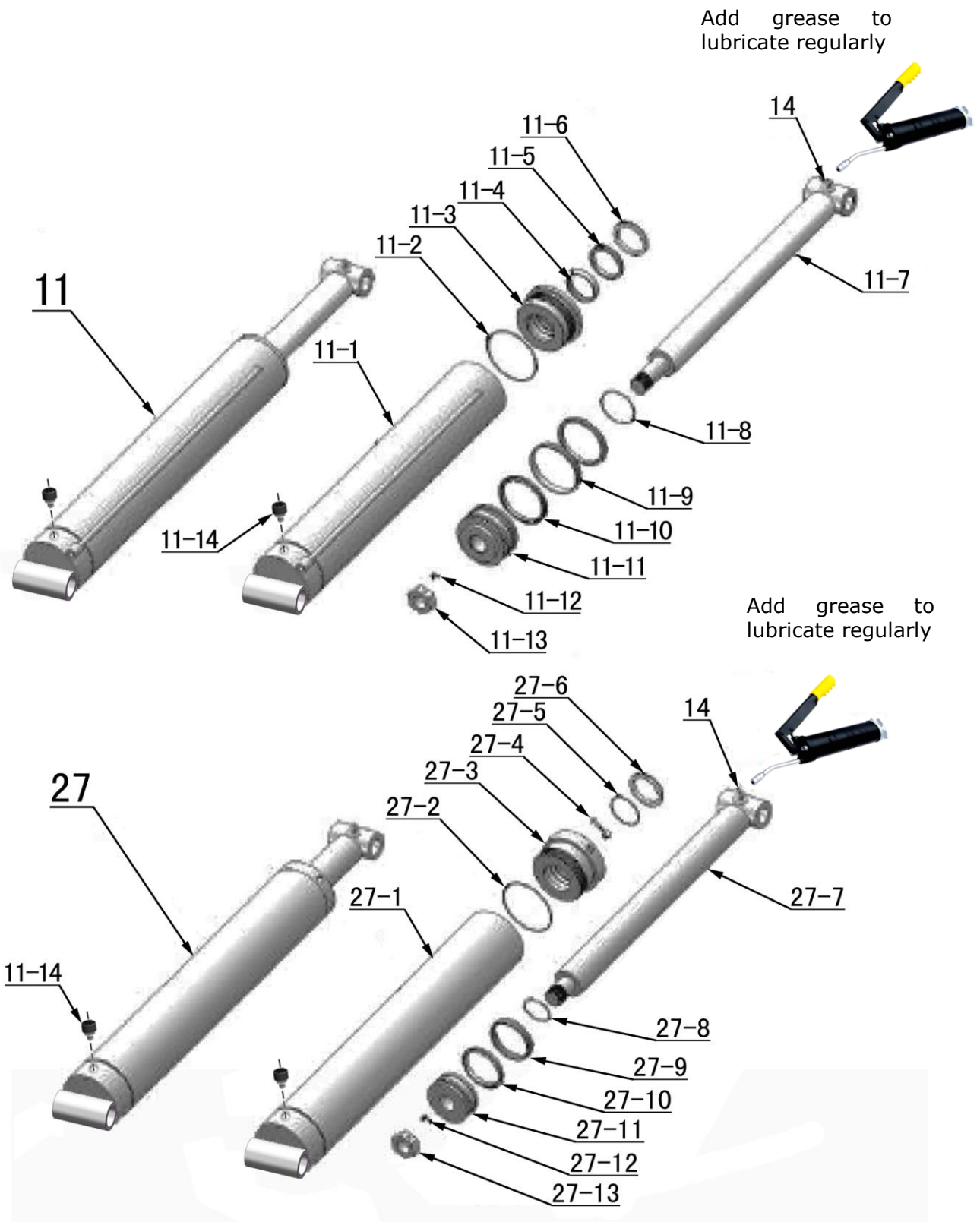


Fig. 42

# CONTROL CABINET

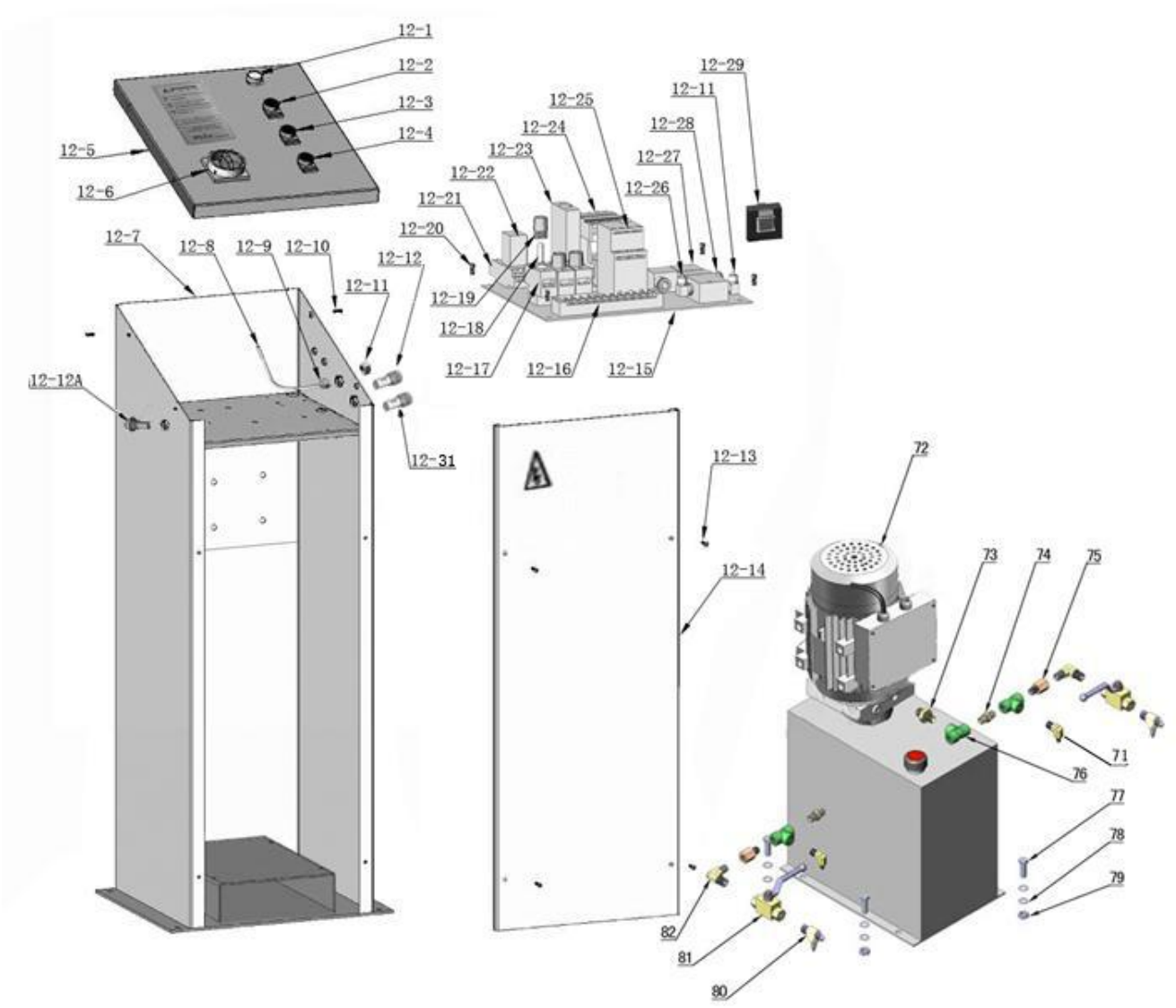
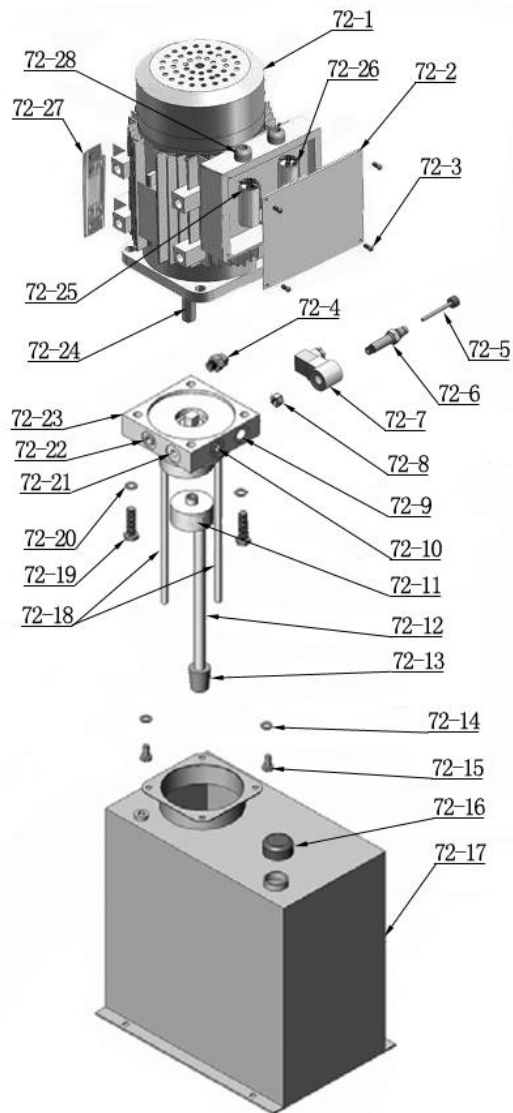


Fig. 43



# INDYPRO ELECTRIC POWER UNIT

## 220V/50HZ/1Phase



## 380V/50HZ/3 Phase

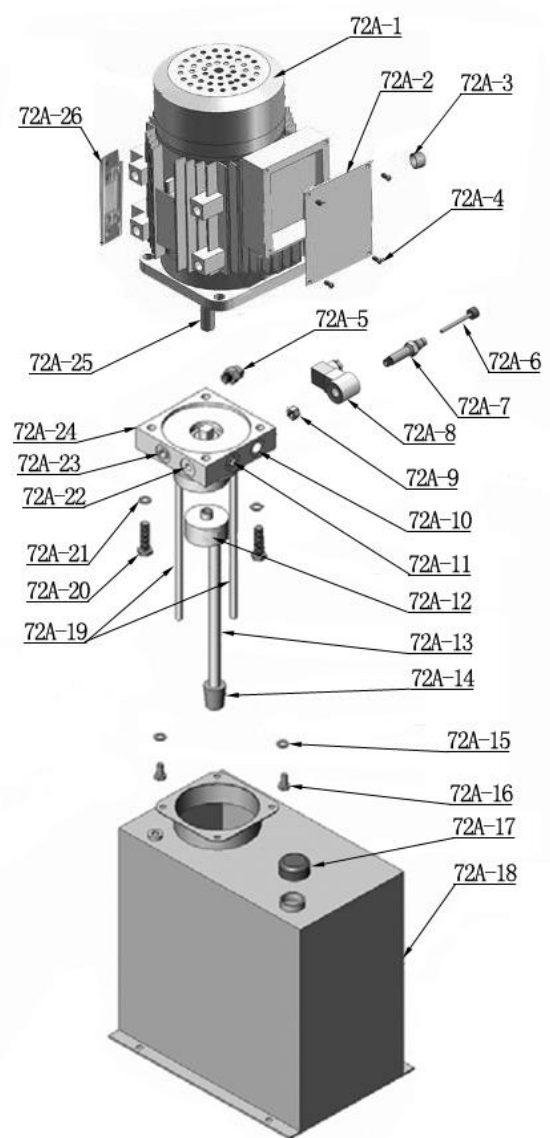


Fig. 44

## V. TEST RUN

### 1. Fill oil adjustment

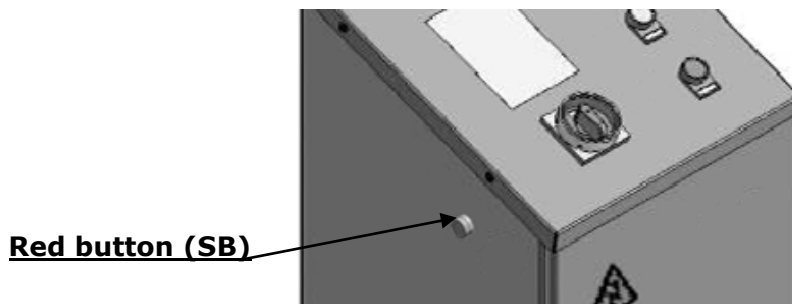
a. Turn on the power after connecting oil system correctly. Press the button **Up**, and check the rotated direction of the motor (This is right if lift is upward, otherwise, it is wrong direction of the motor). Shut off power and exchange the phase connection if the direction is wrong.

b. Fill the reservoir with hydraulic oil. In consideration of power unit's durability and keep the equipment running in the perfect condition, **please use Hydraulic Oil 46#.**

c. Lower the platforms to the lowest position.

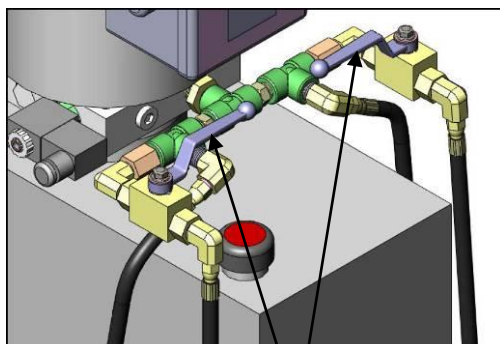
### 2. Synchronous adjustment

a. Turn the handles of the shutoff valves to the position as **Fig. 46** (Normal working position), push button "**UP**" until both platforms up to the position that the high limit switch and stopped, at this time, push button "**UP**" and the red button beside the oil water separator at the same time to raise the lift to the highest position (**See Fig.45**).



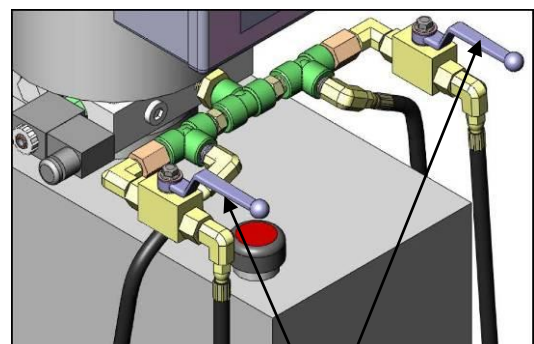
**Fig. 45**

b. Turn the handles of the both shutoff valves to the oil filling position show as **Fig.47**



Normal Working Position

**Fig. 46**



Oil Filling Position

**Fig. 47**

- c. Push button **"UP"** and the Red Button beside the oil-water separator as **Fig. 45** to fill the oil into both secondly cylinders until it is full (to the highest position).
  - d. Turn both handle of the shutoff valves to normal working position (**See Fig. 46**), push button **"Down"** , the lift start to be lowered (If the lift can't be lowered down, turning the handle lever of one valve to oil filling position shown as **Fig. 47**, then quickly turn the handle lever to normal working position, and adjusting another valve with the same way), then the lift can be lowered. Lower the lift to the lowest position.
  - e. Repeat the above procedure **a** to **d** more times, bleeding the air in the cylinder then the lift would be synchronous worked.
3. Test run
- Check the height limit switch, the hose and fitting connection, and do test run. The lift must be tested run and checked carefully before in use.

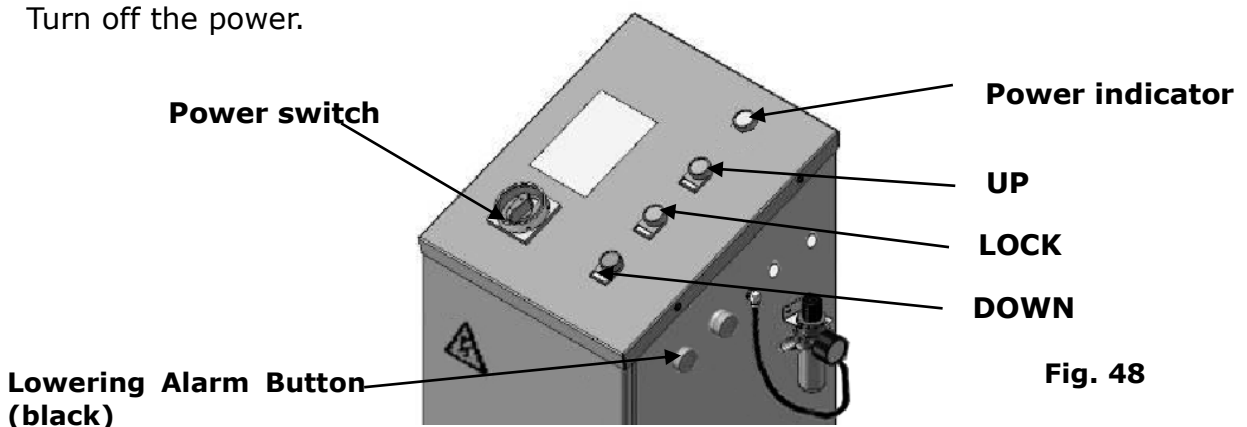
## VI. OPERATION INSTRUCTIONS

### To lift vehicle

1. Keep clean of site near the lift, and down the lift to the lowest position.
2. Drive vehicle on the platforms and pull the brake.
3. Turn on the power and push the button **"Up"**, raise the lift to the working position.  
**Note:** make sure the vehicle is steady when the lift is rising
4. Push the button **"Lock"**, lock the lift in the safety device. Make sure the safety device is locked in the same height.

### To lower vehicle

1. Be sure clear of around and under the lift, only leaving operator in lift area.
2. Push the button **"Down"**, the lift is lowered continually and stopped at the height 600mm from ground. Keep feet clear off lift, push button **"DOWN"** while push the **Lowering Alarm Button(black)** at the side of control cabinet, the lift is lowered to ground with alarm tone;
3. Drive away the vehicle when the lift is lowered to the lowest position.
4. Turn off the power.



**Fig. 48**

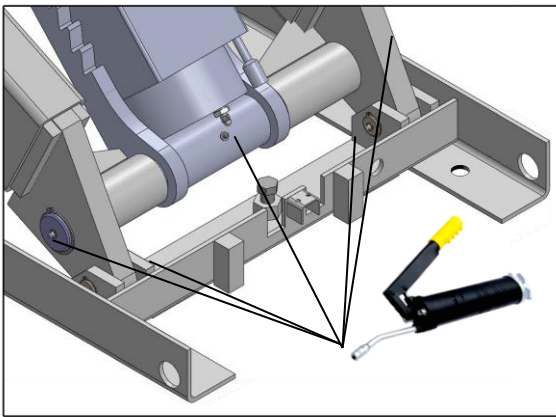
## VII. MAINTENANCE SCHEDULE

### Monthly:

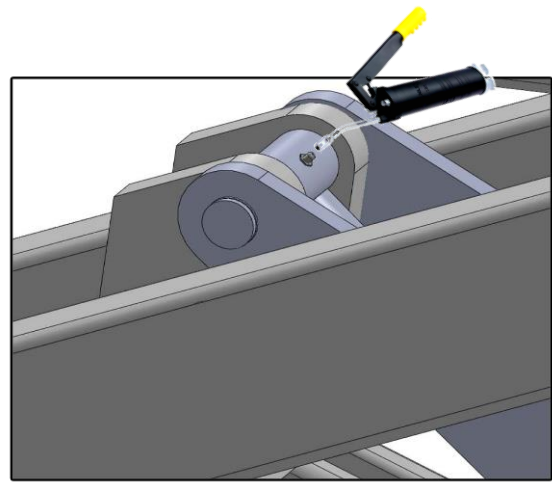
1. Re-torque the anchor bolts to 150 Nm.
2. Check all fittings, bolts and pins to insure proper mounting.

**Note:** All anchor bolts should take full torque. If any of the bolts does not function for any reason, **DO NOT** use the lift until the bolt has been replaced.

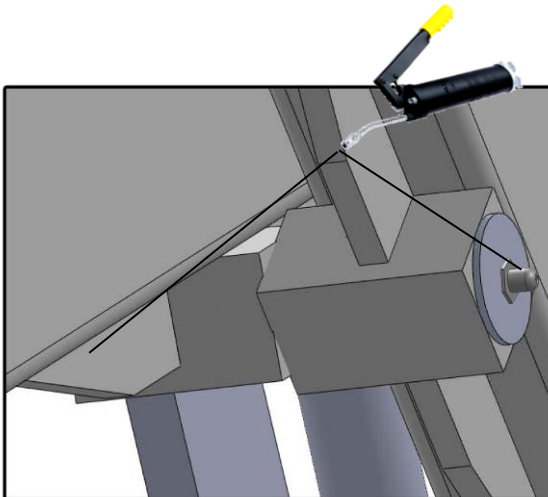
3. Make a visual inspection of all hydraulic hoses/lines for possible wear or leakage.
4. Adjusting the lifting level on both platforms.
5. Lubricate all moving parts with lubricant (**See Fig. 47-52**).



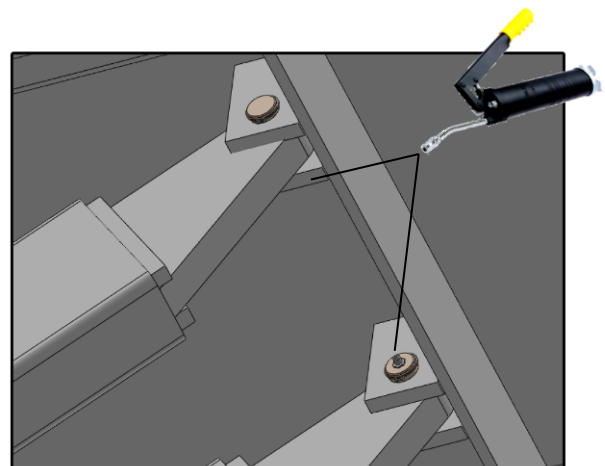
**For Main Cylinder**  
**Fig.49**



**For shaft of piston rod of Main cylinder**  
**Fig.50**

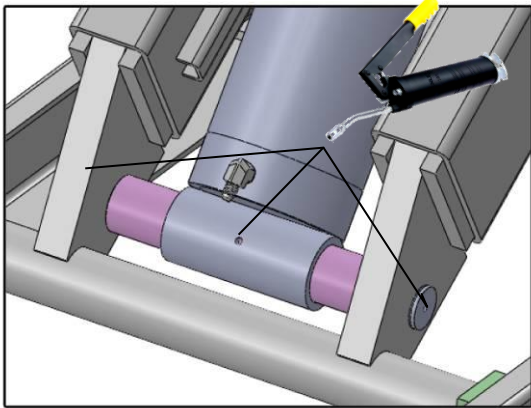


**For pins of connecting  
platforms and scissors**  
**Fig. 51**

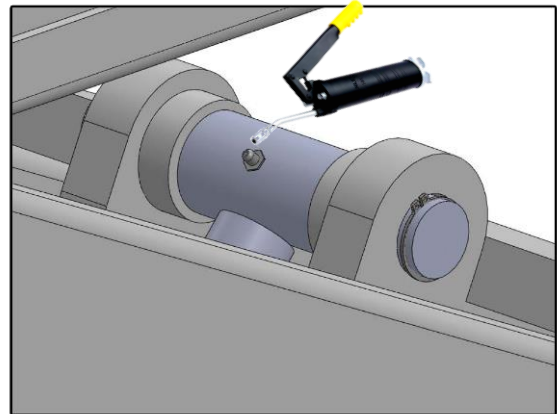


**For pins of connecting  
platforms and scissors**  
**Fig. 52**





**For Secondly Cylinder  
Fig.53**



**For shaft of piston rod of  
Secondly cylinder  
Fig.54**

**Every six months:**

1. Make a visual inspection of all moving parts for possible wear, interference or damage.
2. Check and adjust the platform as necessary to insure level lifting.
3. Check all fastener and re-torque.

## VIII.TROUBLE SHOOTING

TROUBLE	CAUSE	REMEDY
Motor does not run	<ol style="list-style-type: none"> <li>1.Button does not work</li> <li>2.Wiring connections are not in good condition</li> <li>3. AC contactor burned out</li> <li>4. Motor burned out</li> </ol>	<ol style="list-style-type: none"> <li>1. Replace button</li> <li>2. Repair all wiring connection</li> <li>3. Replace AC contactor</li> <li>4. Repair or replace motor</li> </ol>
Motor runs but the lift is not raised	<ol style="list-style-type: none"> <li>1. Motor runs in reverse rotation</li> <li>2. Low oil level</li> <li>3. The Gear Pump out of operation</li> <li>4. Relief valve or check valve in damage</li> <li>5. Hydraulic Solenoid valve out of operation</li> </ol>	<ol style="list-style-type: none"> <li>1. Reverse two power wire</li> <li>2. Fill tank</li> <li>3. Repair or replace</li> <li>4. Repair or replace</li> <li>5. Repair or Replace</li> </ol>
Lift does not stay up	<ol style="list-style-type: none"> <li>1. Hydraulic Solenoid valve out of operation</li> <li>2. Relief valve or check valve leakage</li> <li>3. Cylinder or fittings leaks</li> </ol>	Repair or replace
Lift raised slowly	<ol style="list-style-type: none"> <li>1. Oil line is jammed</li> <li>2. Gear Pump leaks</li> <li>3. Overload lifting</li> <li>4. Power Voltage low</li> <li>5. Oil mixed with air</li> </ol>	<ol style="list-style-type: none"> <li>1. Clean the oil line</li> <li>2. Repair or Replace</li> <li>3. Check load</li> <li>4. Check electrical system</li> <li>5. Fill tank and bleeding air</li> </ol>
Lift cannot lower	<ol style="list-style-type: none"> <li>1. Hydraulic Solenoid valve out of operation</li> <li>2. Air Solenoid Valve out of operation</li> <li>3. Air cylinder in damage</li> <li>4.Low Air pressure</li> </ol>	<ol style="list-style-type: none"> <li>1. Repair or replace the Valve</li> <li>2. Repair or replace the Valve</li> <li>3. Repair or replace</li> <li>4. Check the air line</li> </ol>

**IX. PARTS LIST For Model TLX12A, TLX12**

Item	Part#	Description	QTY		Note
			TLX12 A	TLX12	
1	520003	Shelf assy.	2	2	
2	530002A	Inner Scissors	2	2	
3	530003A	Outer Scissors	2	2	
4	520011	Air Cylinder	2	2	
5	420153	Cup Head Bolt	8	8	
6	510034	Hex Bolt	4	4	
6A	510040	Limit switch assy.	1	1	
7	520013	Connecting Pin	8	8	
8	206032	Snap Ring	16	16	
9	520015C	Base frame	1	1	
9A	520015D	Base frame	1	1	
10	520016A	Main Safety Lock Tube	2	2	
11	520029	Main Cylinder	2	2	
12	520102B	Control Cabinet	1	1	
13	520020	Snap Ring	4	4	
14	620064	Grease Fitting	32	32	
15	520018A	Connecting Shaft For Main Cylinder	2	2	
16	520021A	Safety Lock	2	2	
17	610005A	Connecting pin for Main Cylinder	4	4	
18	610098	Snap Ring	8	8	
19	520024	Connecting Pin For Scissors	4	4	
19A	610019	Self locking nut	4	4	
20	540004D	Offside Platform	1	0	
	530041		0	1	
20A	610108	Washer	4	4	
21	510041	Limit Switch Assy.	1	1	
21A	530023	Washer	4	4	
22	620109	Cup Head Bolt	4	4	
23	420164	Cup Head Bolt	4	4	
24	520023	Snap Ring	4	4	
25	560026A	Connecting Shaft For Secondly Cylinder	2	2	
26	560027	Piston Connecting Tube	2	2	
27	530030	Secondly Cylinder	2	2	
28	520108	Socket Set- screw	4	4	
29	520024A	Pin For Pulley	4	4	
30	530042	Bronze Bush	8	8	
31	530012	Slider	8	8	
32	520103	Hex Bolt	8	0	
	510016	Hex Bolt	0	8	
33	420175A	Hex Nut	12	12	
34	540005D	Powerside Platform	1	0	

	530040		0	1	
--	--------	--	---	---	--

Item	Part#	Description	Qty.		Note
			TLX12 A	TLX12	
35	420157	Steel Ball	58	0	
36	570003	Rear Slip Plate	2	0	
37	520037	Pin for Rear Slip Plate	4	0	
38	560003	Plate for Adjustable Turnplate	2	0	
39	530001B	Runway Connecting Bar	1	1	
40	206023B	Hex Nut	8	8	
41	420026	Lock Washer	8	8	
42	206006	Washer	8	8	
43	420136	Hex Bolt	12	8	
44	520005A	Drive-in Ramp(On surface/Flush mount)	2/0	0	
	510004A		0	2/0	
44A	209010	Snap Ring	8	16	
44B	620043	Pin for Drive-in Ramp roller	4	8	
44C	620063	Drive-in Ramp roller	4	8	
45	510006	Pin For Drive-in Ramp	2	4	
46	201005	Split Pin	4	8	
47	510018	Guild Ramp (On surface/Flush mount)	0/2	0	
	510019		0	2/4	
48	520004A	Tire Stop Plate	2	0	
49	209059	Anchor Bolt	14	14	
50	620071	Anchor Bolt	4	4	
51	420047	Quick Fitting for Air Cylinder	2	2	
52	520065	Spring Air Line	2	2	
53	510036	Air Line (Black)	1	1	
54	420124	T-fitting	1	1	
55	520069	90° Quick fitting for air line	1	1	
56	620079	Straight Fitting	6	6	
57	203119	Oil Hose No.①	1	1	
58	540020	Oil Hose No.②	1	1	
59	540019	Oil Hose No.③	1	1	
60	540022	Oil Hose No④	1	1	
61	540018	Oil Hose No.⑤	1	1	
62	540017	Oil Hose No.⑥	1	1	
63	510023	Straight Fitting	2	2	
64	520101	Protective Plastic Hose	2	2	
65	540023	Oil hose	2	2	
66	420119	Straight Fitting for cylinder	2	2	
66A	540021	Oil hose	2	2	
66B	540030	Oil hose	2	2	
67	420076	90° Fitting For Air Line	1	1	
68	420145	Oil-water Separator	1	1	



Item	Part#	Description	Qty		Note
69	420146	Straight Fitting for air line	1	1	
70	680005	Cup Head Bolt	4	4	
71	420097	90° Fitting	4	4	
71A	510024	Fitting	2	2	
72	550003	Power unit	1	1	
73	440009	Straight Fitting for power unit	1	1	
74	206062	Straight Fitting	2	2	
75	630103	Straight Fitting	2	2	
76	61K107	T- Fitting	3	3	
77	61K050	Hex Bolt	4	4	
78	209033	Washer	8	8	
79	209005	Self locking Nut	4	4	
80	209062	T- Fitting	2	2	
81	61K101	Shutoff Valve	2	2	
82	680072	90° Fitting	2	2	
83	420018	Self locking Nut	2	2	
84	510039	Cup Head Bolt	3	3	
85	540029	Oil hose cover	1	1	
86	540024	Oil hose cover(L=600mm)	2	2	
87A	620065	Shim(2mm)	20	20	
87B	201090	Shim(1mm)	20	20	
88	540025	Oil Hose Cover (L=748mm)	1	1	
88A	540027	Oil Hose Cover(L=1060mm)	3	3	
89	620070	Colloidal	36	36	
90	620069	Wood Screw	36	36	
91	540500A	Parts box (On surface installation)	1	0	
92	530500A	Parts box (On surface installation)	0	1	
93	540501A	Parts box (Flush mount installation)	1	0	
94	530501A	Parts box (Flush mount installation)	0	1	
95	420158	Turnplate (optional)	2	0	
<b>Parts for Optional Air Line Kits</b>					
96	420213	T Fitting	1	1	
97	540007	T Fitting	1	1	
98	61K094	90° Fitting	2	2	
99	61K092	Hex Nut	2	2	
100	430010	Washer	2	2	
101	61K091	Straight Fitting for Air Line	2	2	
102	61K090	C shape female fitting	2	2	
103	540009	φ 8* φ 6 Air Line	1	1	
104	420146	Male quick fitting	2	2	
105	520065A	Air Line	2	2	

<b>Parts For Main Cylinder</b>					
11-1	530032	Main Cylinder	1	1	
11-2	530025	O- Ring	1	1	
11-3	530033	Head Cap (Main)	1	1	
11-4	530028	Support Ring	1	1	
11-5	530024	Y- Ring	1	1	
11-6	530026	Dust Ring	1	1	
11-7	530034	Piston Rod (Main)	1	1	
11-8	520054	O- Ring	1	1	
11-9	530027	Support Ring	1	1	
11-10	520063	Y- Ring	2	2	
11-11	530035	Piston (Main)	1	1	
11-12	520049	Set Screw	1	1	
11-13	520047	Hex Nut	1	1	
11-14	530009	Burst valve	4	4	
<b>Parts For Secondly Cylinder</b>					
27-1	530036	Secondly Cylinder	1	1	
27-2	420062	O- Ring	1	1	
27-3	530037	Head Cap (Secondly)	1	1	
27-4	201034	Bleeding Plug	2	2	
27-5	520058	O- Ring	1	1	
27-6	217078	Dust Ring	1	1	
27-7	510011B	Piston Rod (Secondly)	1	1	
27-8	520061	O- Ring	1	1	
27-9	420066	Support Ring	1	1	
27-10	420067	Y- Ring	1	1	
27-11	530039	Piston (Secondly)	1	1	
27-12	520049	Set Screw	1	1	
27-13	420014	Hex Nut	1	1	
<b>Parts List For Control Cabinet (See Fig. 41)</b>					
12-1	201094	Power indicator	1	1	
12-2	420071	Button <b>UP</b>	1	1	
12-3	420071	Button <b>LOCK</b>	1	1	
12-4	420072	Button <b>DOWN</b>	1	1	
12-5	52K001C	Control Panel	1	1	
12-6	420074	Power Switch (QS)	1	1	
12-7	52K007D	Cabinet Body	1	1	
12-8	420167C	Air line	2	2	
12-9	61K110	Straight Fitting	1	1	
12-10	209145	Cup Head Bolt	4	4	
12-11	420076	90° Fitting	2	2	
12-12	420143	Buzzer	1	1	
12-12A	650017	Red button (SB)	1	1	
12-13	52K056	Cup Head Bolt	4	4	
12-14	52K022	Cabinet Door	1	1	
12-15	52K006A	Install panel	1	1	
12-16	620082	Terminal	1	1	
12-17	420087	Fuse base	3	3	
12-18	420086	Fuse(FU)	3	3	

12-19	420085	Fuse Cap	3	3	
12-20	61K052	Cup head bolt	19	19	
12-21	420135	Timer Relay Base	2	2	
12-22	420141	Intermediate Relay(KA)	1	1	
12-23	420083	Timer Relay(KT)	1	1	
12-24	420084A	AC Contactor (KM)	1	1	
12-25	440034	Thermal Relay(FR)	1	1	
12-26	420166	90° Fitting	1	1	
12-27	420077	Air Solenoid Valve(Y2)	1	1	
12-28	201034	Bleeding plug	1	1	
12-29	420134	Transformer (TC)	1	1	
12-30	540008	Protected Ring	2	2	
12-31	420142	Lowering Alarm Button (k)	1	1	

### Parts For INDYPRO Electric Power Unit 220V/50HZ/1 Phase

Item	Part#	Description	QTY.		Note
			TLX12A	TLX12	
72-1	81400199	Motor	1	1	
72-2	81400208	Cover of Motor Terminal Box	1	1	
72-3	680005	Cup Head Bolt	4	4	
72-4	81400192	Check Valve	1	1	
72-5	81400196	Release Valve Adjusting Rod	1	1	
72-6	81400195	Hydraulic Solenoid Valve Body	1	1	
72-7	81400195	Hydraulic Solenoid Valve Coil	1	1	
72-8	81400193	Hydraulic Solenoid Valve Nut	1	1	
72-9	81400174	Connecting of power unit	2	2	
72-10	81400178	Protective Ring	2	2	
72-11	81400158	Gear Pump	1	1	
72-12	81400213	Inlet Pipe	1	1	
72-13	81400150	Filter	1	1	
72-14	440035	Washer	4	4	
72-15	81400145	Socket Bolt	4	4	
72-16	81400217	Filler Cap	1	1	
72-17	81400214	Reservoir	1	1	
72-18	81400215	Oil Return Pipe	2	2	
72-19	81400148	Socket Bolt	4	4	
72-20	209149	Lock Washer	4	4	
72-21	81400107	Throttle Valve	1	1	
72-22	81400106	Relief Valve	1	1	
72-23	81400216	Valve Body	1	1	
72-24	81400127	Motor Connecting Shaft	1	1	
72-25	81400207	Running Capacitor	1	1	
72-26	81400074	Star Capacitor	1	1	

**Parts For INDYPRO Electric Power Unit 380V/50HZ/3 Phase**

Item	Part#	Description	QTY.		Note
			TLX12A	TLX12	
72A-1	81400201	Motor	1	1	
72A-2	81400209	Cover of Motor Terminal Box	1	1	
72A-3	81400178	Protect Ring	1	1	
72A-4	680005	Cup Head Bolt	4	4	
72A-5	81400192	Check Valve	1	1	
72A-6	81400196	Release Valve Adjusting Rod	1	1	
72A-7	81400195	Hydraulic Solenoid Valve Body	1	1	
72A-8	81400194	Hydraulic Solenoid Valve Coil	1	1	
72A-9	81400193	Hydraulic Solenoid Valve Nut	1	1	
72A-10	81400127	Motor Connecting Shaft	1	1	
72A-11	81400174	Connecting of power unit	2	2	
72A-12	81400206	Gear Pump	1	1	
72A-13	81400213	Inlet Pipe	1	1	
72A-14	81400150	Filter	1	1	
72A-15	440035	Washer	4	4	
72A-16	81400145	Socket Bolt	4	4	
72A-17	81400217	Filler Cap	1	1	
72A-18	81400214	Reservoir	1	1	
72A-19	81400215	Oil Return Pipe	2	2	
72A-20	81400148	Socket Bolt	4	4	
72A-21	209149	Lock Washer	4	4	
72A-22	81400107	Throttle Valve	1	1	
72A-23	81400106	Relief Valve	1	1	
72A-24	81400216	Valve Body	1	1	



Exclusively for: TOMAD International, Inc. 8847 Commerce Park Place Suite A,  
Indianapolis 46268 - USA Tel: (317) 8 7 0-1199 Fax: (317) 8 7 6 -7344  
**[www.indypro.us](http://www.indypro.us)**