

The Heavy-duty scissors lifts use four cylinders to support and each both cylinders are designed working synchronously.

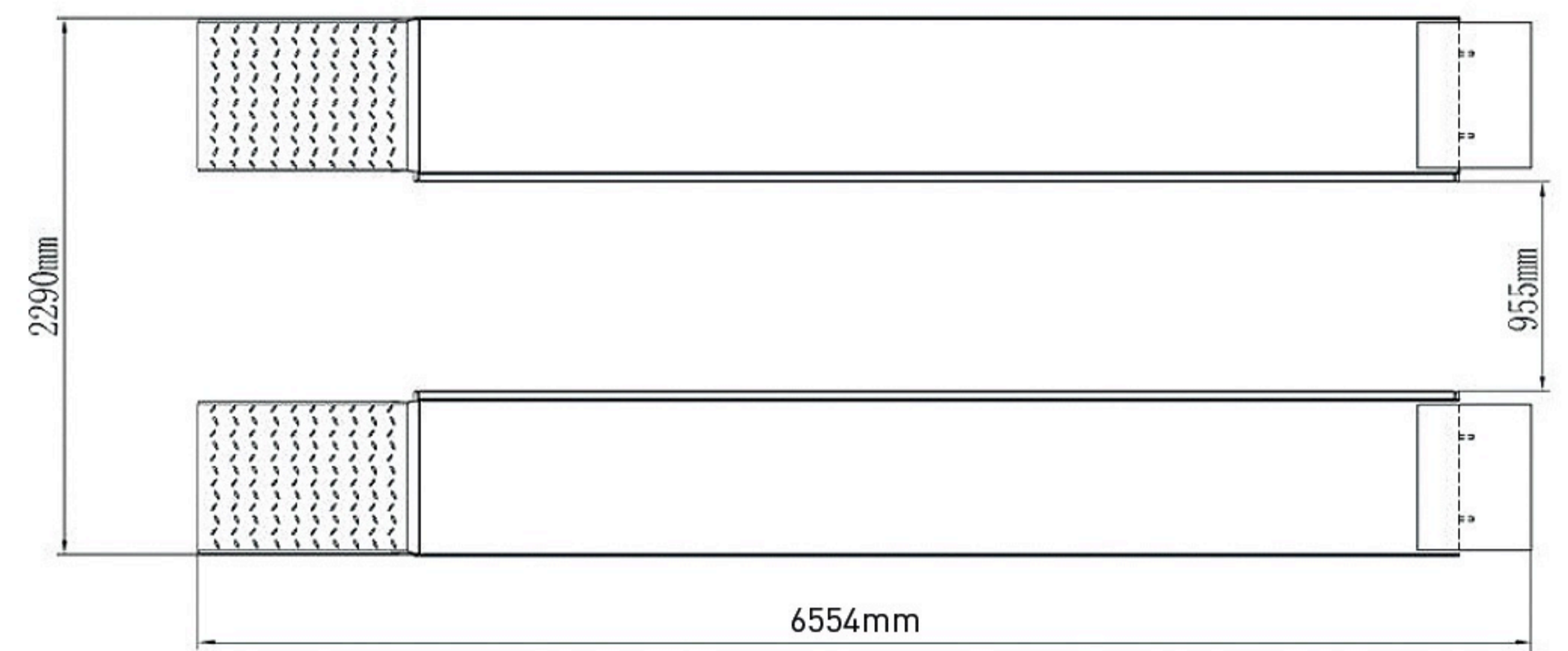

## FEATURES

- 2-dual synchronous cylinders are applied to assure the lifting level on both platforms
- Electro-air control system, safety self-lock mechanism
- Skid proof diamond runway
- Integrated rear slip-plates
- Heavy duty design, the X serial scissors lifts use 150 x75 mm tube to make it strong and assure the runways remain level during working
- Optional Jack and Turnplate

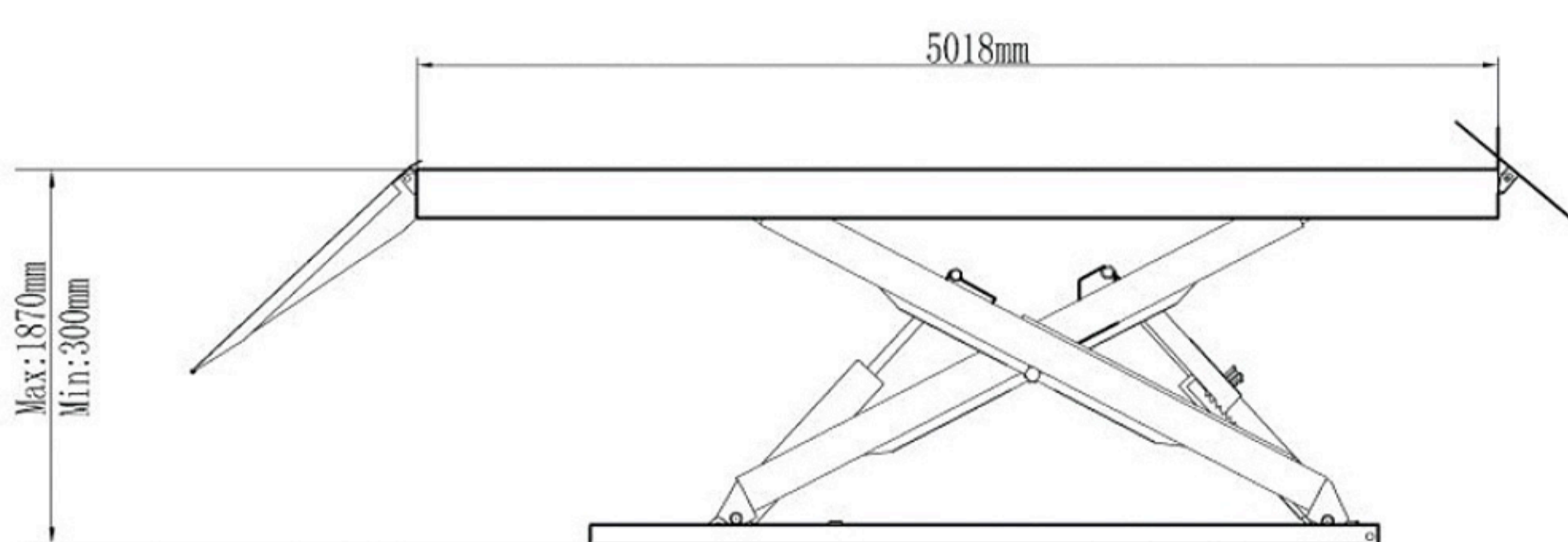

## SPECIFICATIONS

Model	Lifting Capacity	Lifting Time	A		B	C	D	E	Gross Weight	Motor
			Lifting Height	Minimum Height	Runway Length	Overall Width	Runway Width	Overall Length (Inc. Ramps)		
TLX12A	5.5T (12,000 lbs)	58 Seconds	1870 mm (73 5/8")	300mm (11 3/4")	5018 mm (197 1/2")	2290 mm (90 1/8")	625 mm (24 5/8")	6554 mm (258")	2320kg (5,105 lbs)	4.0HP



Electro-air Safety Device



Shelf For Service



Optional Turnplate



New rear-slip ball sets