



INDYPRO

LIFTS & EQUIPMENT



FLUSH MOUNT

TX8F

Installation/Operation/Service Manual

CONTENTS

Product Features and Specifications	1
Installation Requirement	2
Steps of Installation.....	4
Exploded View	13
Test Run.....	18
Operation Instruction	19
Maintenance	19
Trouble Shooting	20
Parts List	21

I. PRODUCT FEATURES AND SPECIFICATIONS (See Fig.1)

FLUSH-MOUNT SCISSORS MODEL TX8F

- Electric/Hydraulic power system.
- Dual cylinders automatic synchronization system.
- Safety self-lock mechanism.
- Extended platforms.



Fig. 1

MODEL TX8F SPECIFICATIONS

Model	Lifting Capacity	Lifting Height	Min. Height	Lifting Time	Overall Length	Runway Width	Width Between Bases	Gross Weight	Motor
TX8F	3.5T 8,000lbs	2230mm 87 7/8"	350mm 13 3/4"	51S	1550-1750mm 61"-68 7/8"	550mm 21 5/8"	800mm 31 1/2"	822Kg 1,800lbs	2.0/3.0 HP

II. INSTALLATION REQUIREMENT

A. TOOLS REQUIRED

- ✓ Rotary Hammer Drill
(Φ19、Φ10、Φ4)



- ✓ Hammer



- ✓ Level Bar

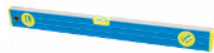

- ✓ English Spanner (12")



- ✓ Wrench set (15#, 17#)



- ✓ Grease gun



- ✓ Carpenter's Chalk



- ✓ Screw Sets



- ✓ Tape Measure (7.5m)



- ✓ Pliers



- ✓ Lock Wrench



- ✓ Ratchet Spanner with Socket



Fig. 2

B. SPECIFICATIONS OF CONCRETE

Specifications of concrete must be adhere to the specifications as following. Failure to do so may result in lift and/or vehicle falling.

1. Lift Location: Always use architect plans when available. Check layout dimension against floor plan requirements making sure that adequate space is available.
2. Overhead Obstructions: The area where the lift will be located should be free of overhead obstructions such as heaters, building supports, electrical lines etc.
3. Concrete: Visually inspect the site where the lift is to be installed and check for cracked or defective concrete. All models must be installed on 3000psi (210kg/cm²) minimum. Concrete with a thickness 100mm and without reinforcing steel bars.

C. POWER SUPPLY

The electrical source must be 2.2KW minimum. The source cable size must be 2.5mm² and in good condition of contacting with floor.

WARNING !

A level floor is suggested for proper installation and level adjustment. Small differences in floor slopes may be compensated by shim. If a floor is of questionable slope, consider pouring a new concrete slab.

- ✓ **DO NOT** install this lift on any asphalt surface or any surface other ground than concrete.
- ✓ **DO NOT** install this lift on expansion seams or on cracked or defective concrete.
- ✓ **DO NOT** install this lift on a second/elevated floor without first consulting build architect.
- ✓ **DO NOT** install this lift outdoors unless special consideration has been made to protect the power unit from weather conditions.

III. STEPS OF INSTALLATION

A. Location of installation (See Fig. 3)

Review the layout as shown below and select a location that is best suited for your application. Be sure to use the dimensions that are applicable to your lift model.

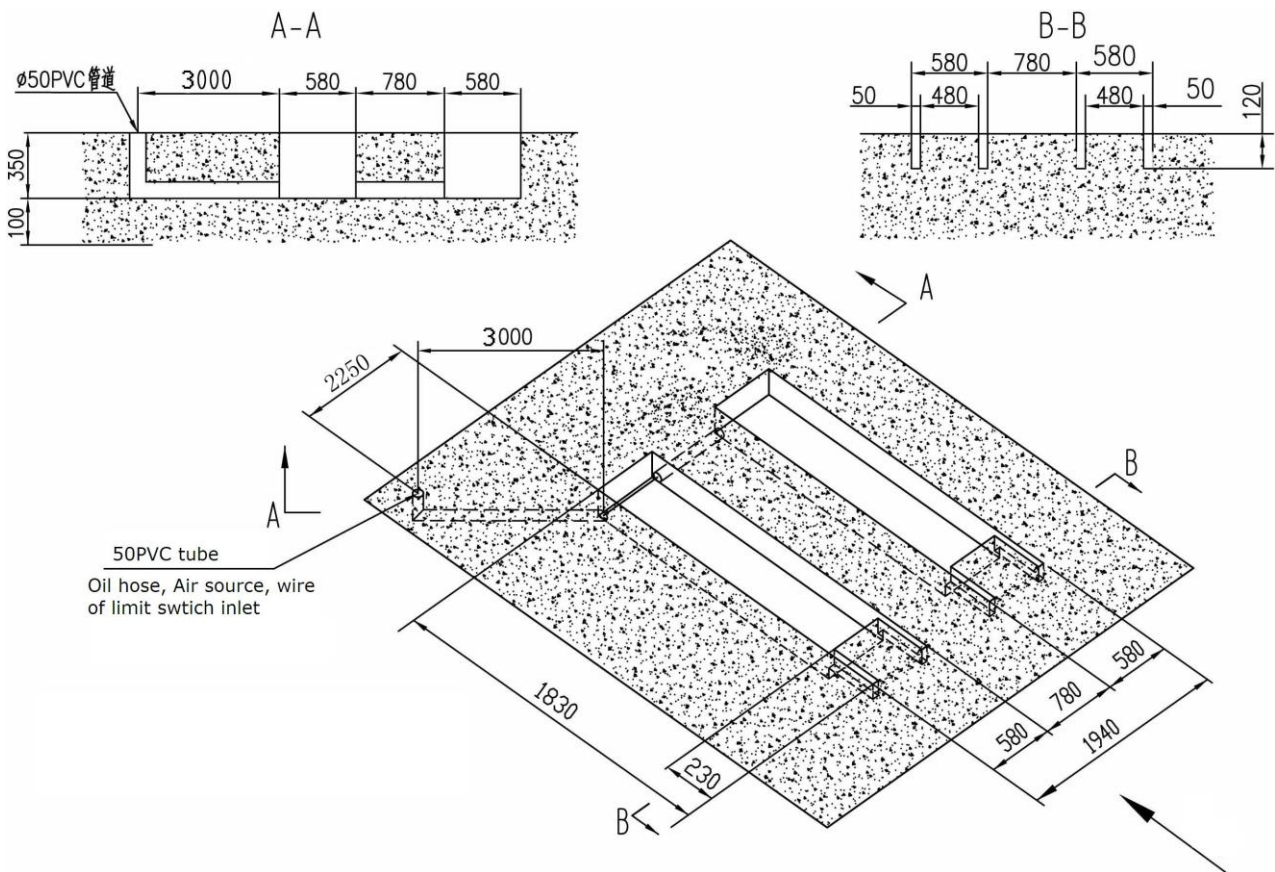

Fig. 3

- Note:**
1. Concrete must be thickness 100mm minimum and must be of test strength 3,000psi (210kg/cm²) minimum.
 2. All the tubes must be $\Phi 50$ PVC tube.

B. Check the parts before assembly, make sure all the parts are completed.

1. Packaged lift, parts box, control cabinet (**See Fig.4**).



Fig. 4

2. Move the parts aside, open the outer packing and check the parts according to the shipment parts list (**See Fig. 5**).

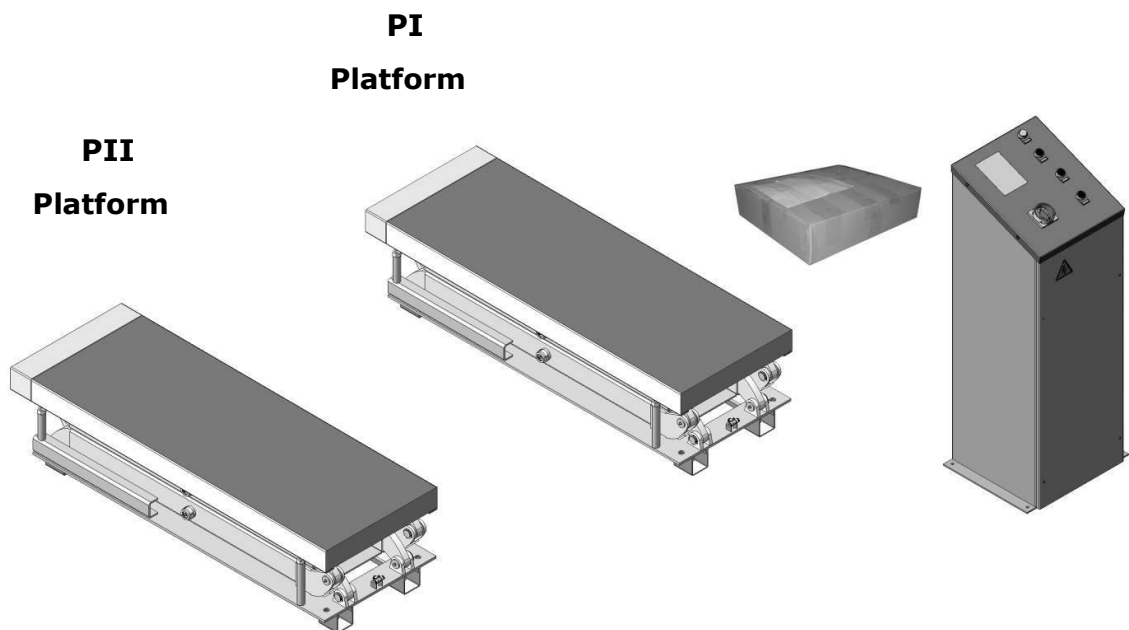

Fig. 5

3. Open the parts box, check the parts according to the part list (See Fig. 6).



Fig. 6

4. Check the parts of the parts bag according to the parts bag list (See Fig. 7).

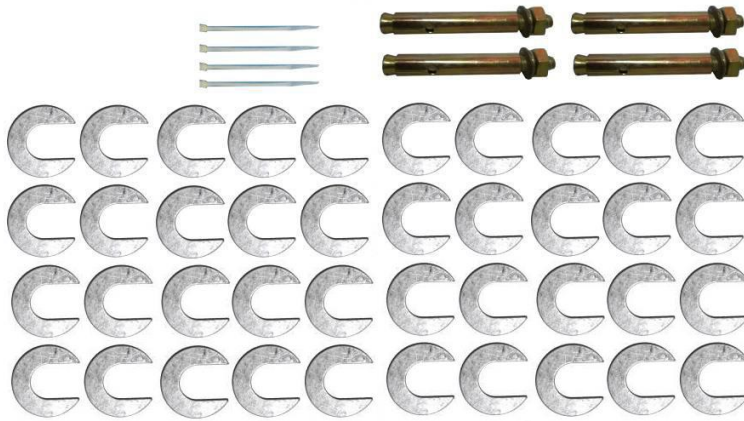

Fig. 7

C. Layout the machine and install oil system and air line system.

1. Select a location and layout the equipment according to steps B (See Fig. 8).

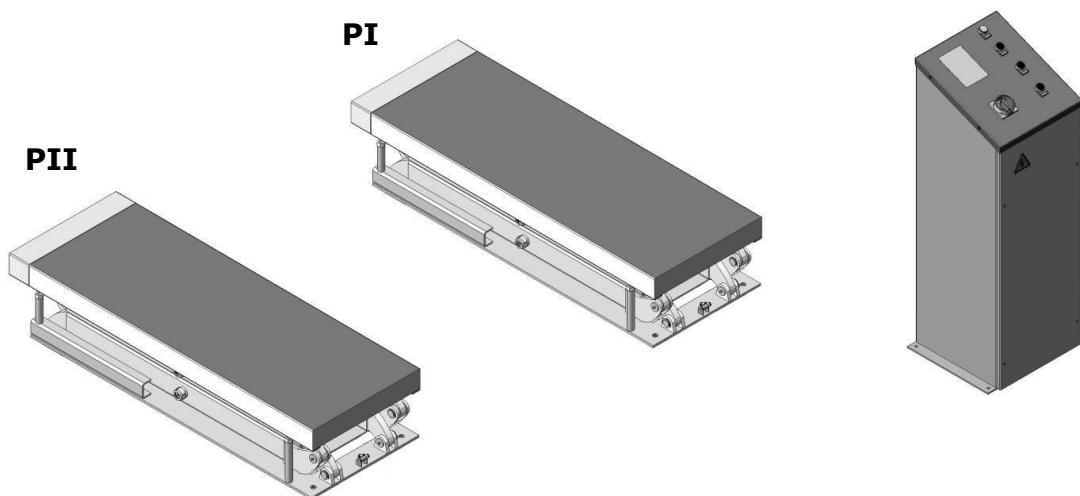

Fig. 8

2. Connecting the oil hose and air line (See Fig. 9).

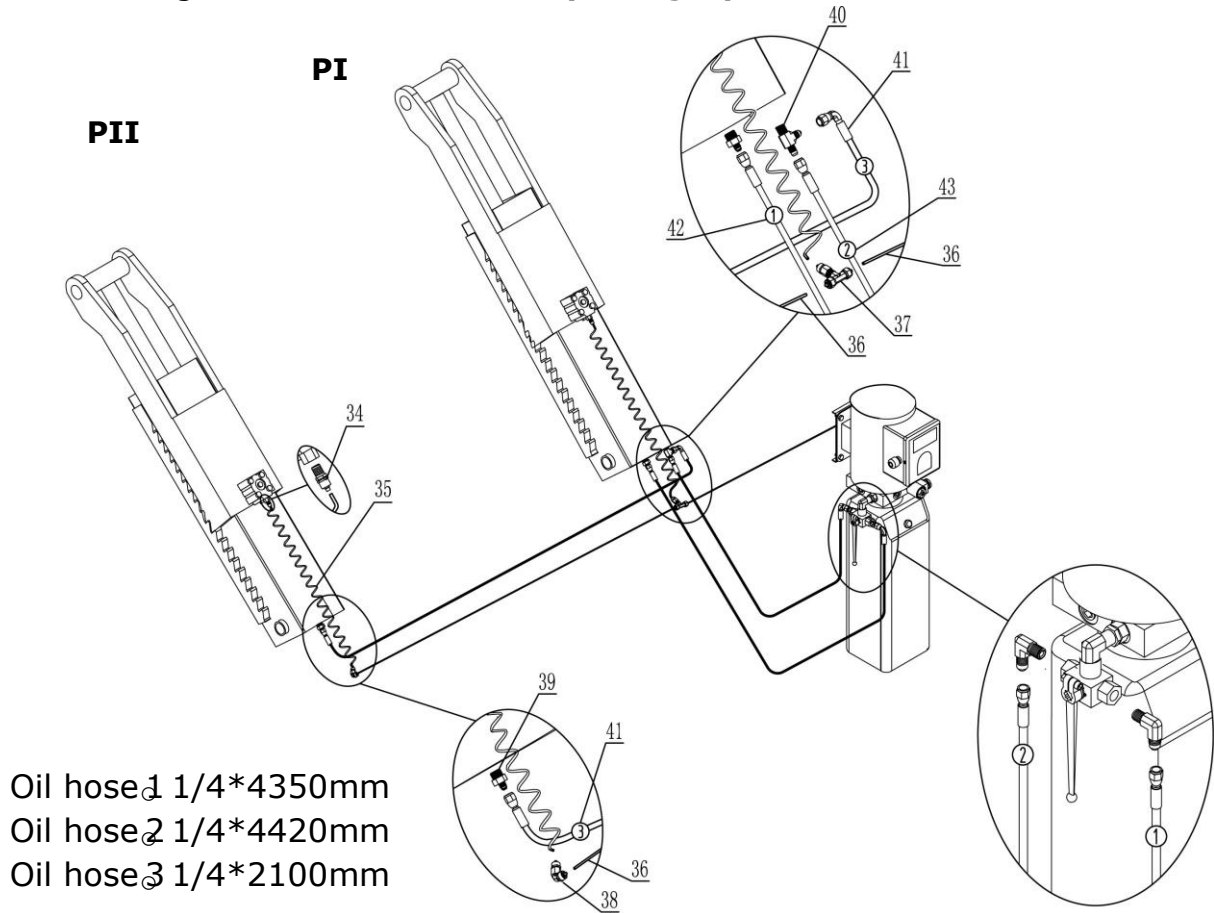

Fig. 9

3. Install the oil-water separator (See Fig. 10).

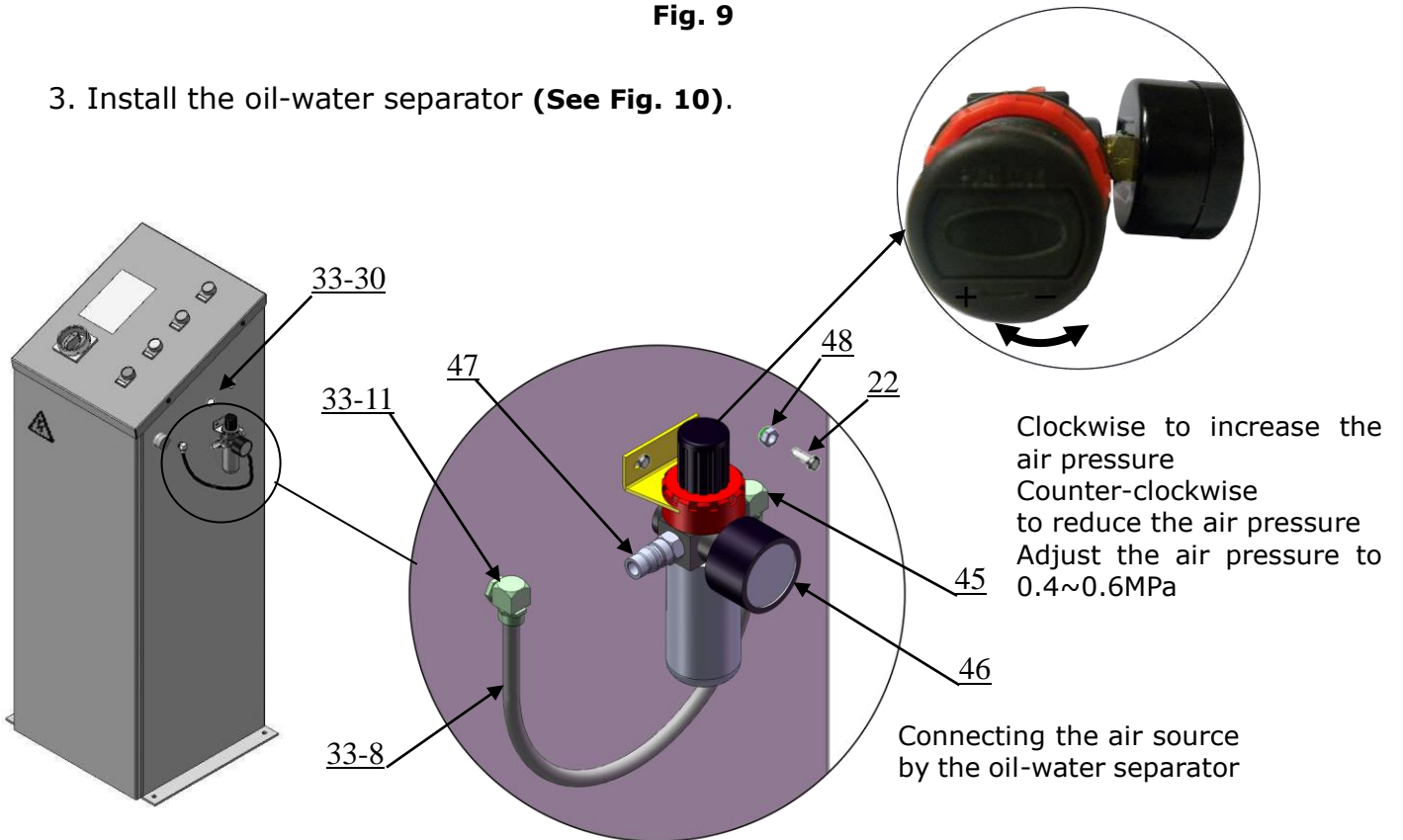

Fig. 10

D. Install electric system

1. Adjusting the current rating of thermal relay in control box according to the different configurations of hydraulic power unit. In general, the electric current of thermal relay should equal or larger than that of motor. The following table shows rated current regulation of thermal relay in case of different hydraulic power unit.

Hydraulic power unit	Single phase	Three phase
Rated current of thermal relay	18A	12A

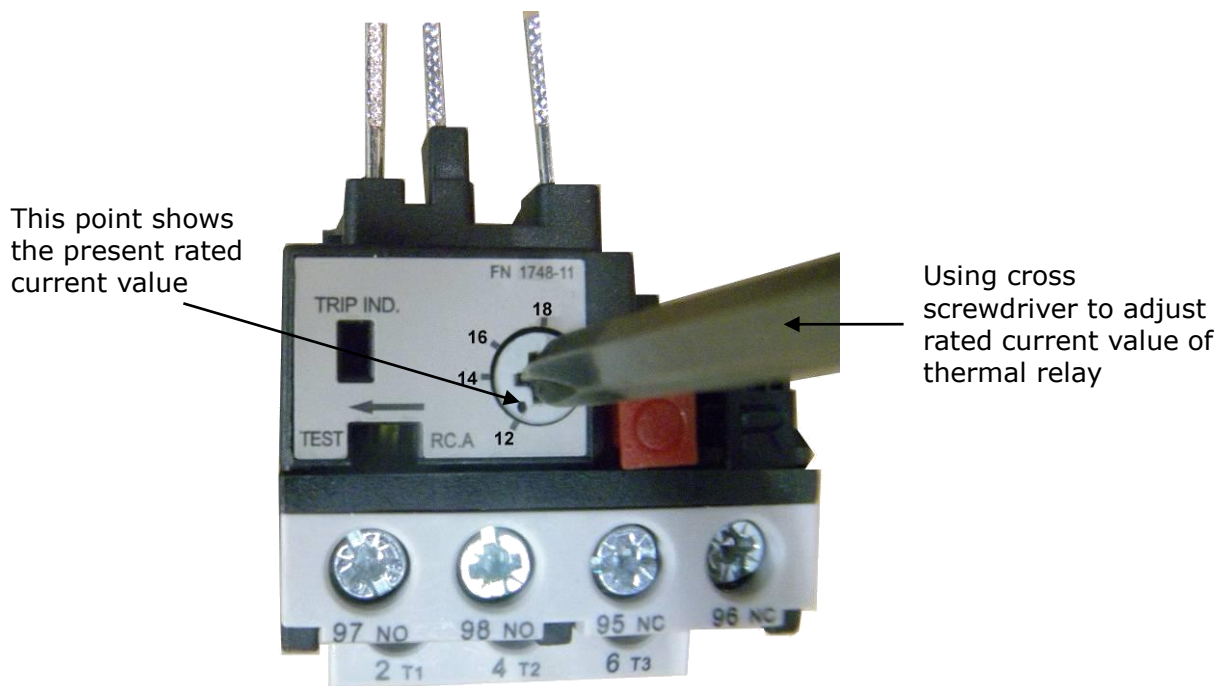

Fig. 11

2. Wire connection for hydraulic power unit (for 3 phase)

2.1 Connect the power wire and limit switch wire according to the Wiring diagram (See Fig. 12).

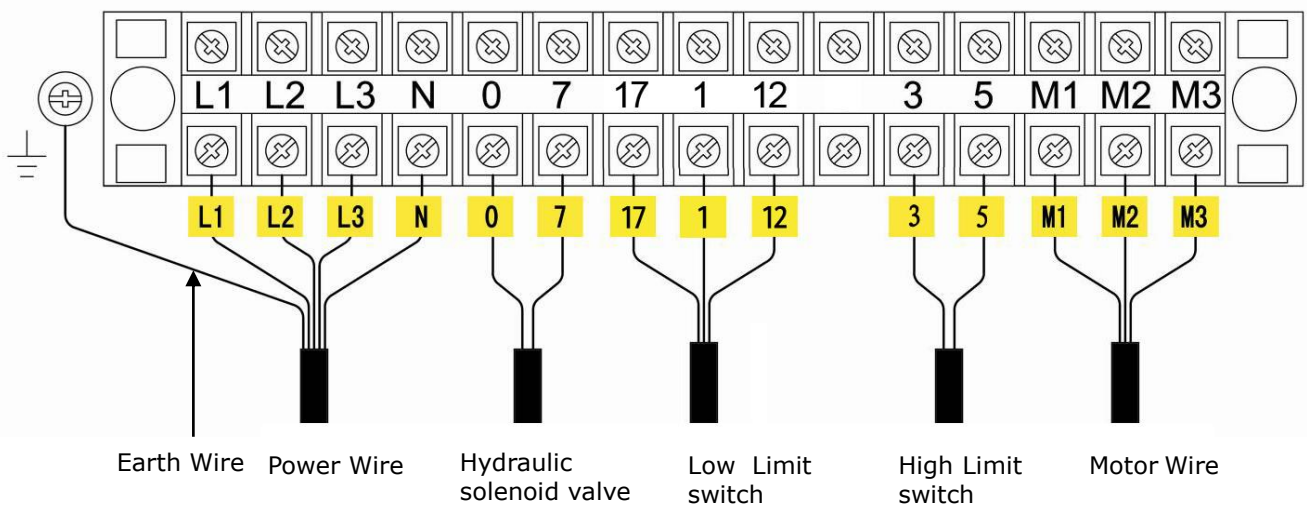

Fig. 12

2.2 Circuit Diagram (See Fig. 13).

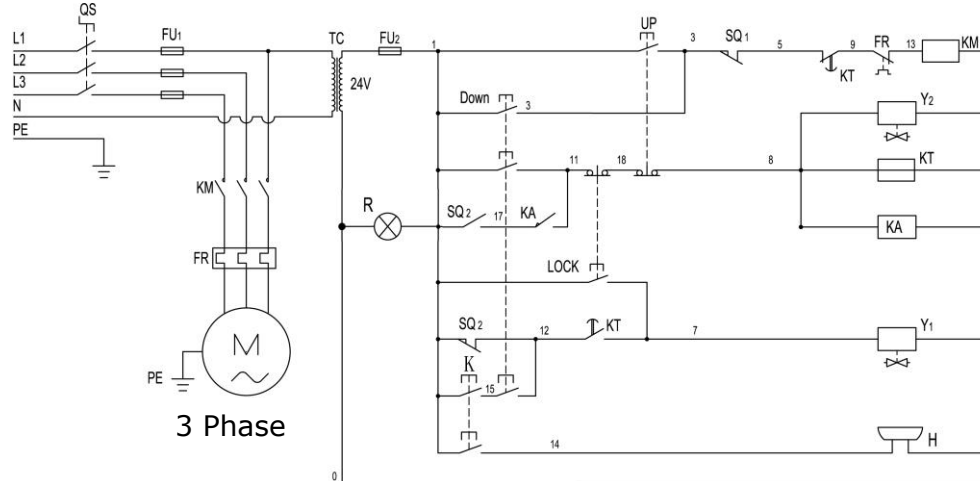

Fig. 13

Electric Component

Item	Name	Code	Specification	Item	Name	Code	Specification
1	Power switch	QS	380V AC	10	Push button	Up	Duplex
2	Fuse	FU1	25A	11	Push button	Lock	Duplex
3	Fuse	FU2	3A	12	Push button	Down	Trigeminy
4	AC contactor	KM	24V AC	13	Lower alarm button	K	Duplex
5	Thermal relay	FR	12A-18A	14	Motor	M	3 Phase
6	Time relay	KT	24V AC	15	Buzzer	H	24VAC
7	Limit switch	SQ _(1~2)	10A	16	Transformer	TC	24V AC
8	Hydraulic solenoid valve	Y1	AC 24V	17	Intermediate relay	KA	24VAC
9	Air solenoid valve	Y2	AC 24V	18	Power indicator	R	24VAC

3. Wire connection for hydraulic power unit (for single phase)

3.1 Connect the power wire and limit switch wire according to the Wiring diagram (See Fig. 14)

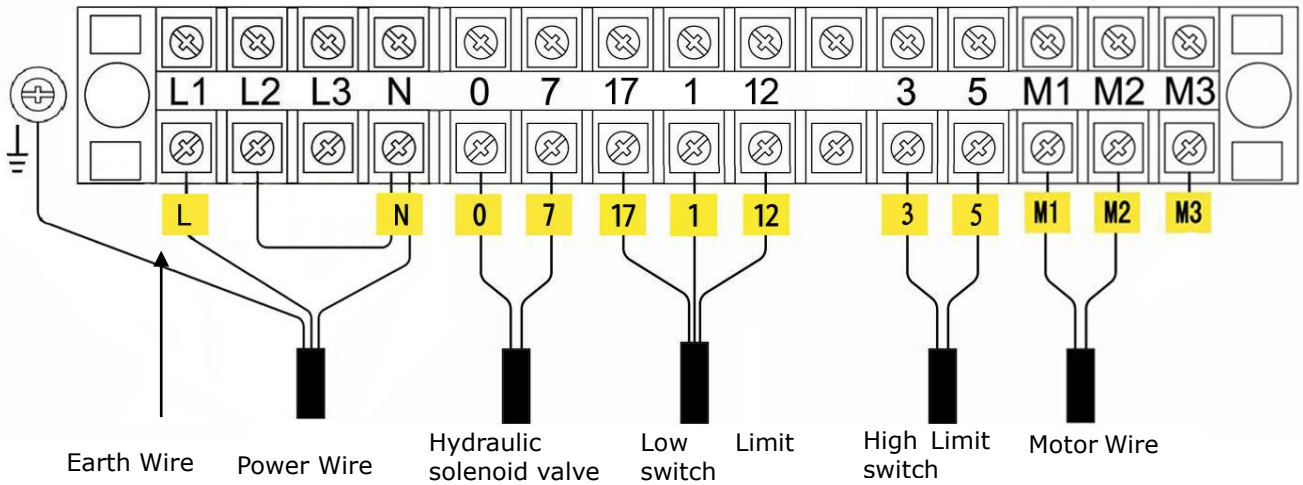

Fig. 14

3.2 Circuit Diagram (See Fig. 15).

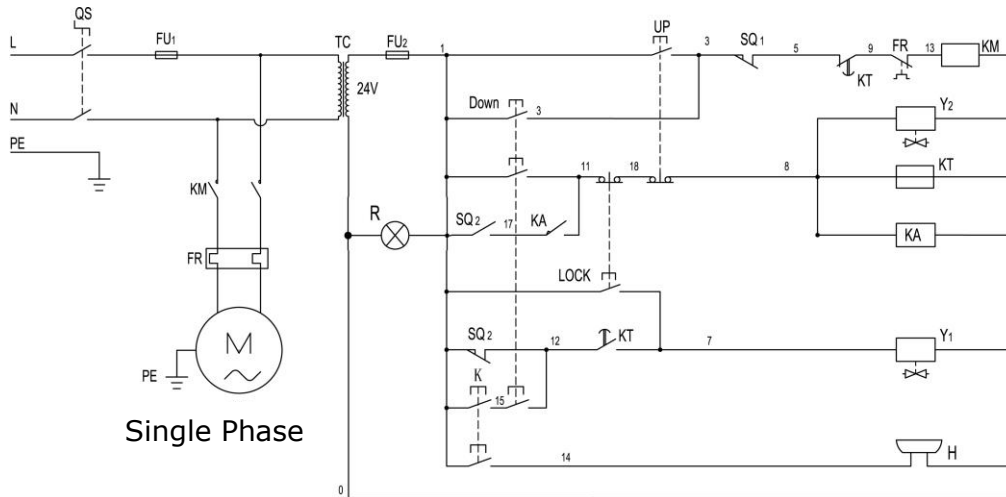

Fig. 15

Electric Component

Item	Name	Code	Specification	Item	Name	Code	Specification
1	Power switch	QS	380V AC	10	Push button	Up	Duplex
2	Fuse	FU1	25A	11	Push button	LOCK	Duplex
3	Fuse	FU2	3A	12	Push button	Down1	Trigeminy
4	AC contactor	KM	24V AC	13	Lower alarm button	K	Duplex
5	Thermal relay	FR	12A-18A	14	Motor	M	Single phase
6	Time relay	KT	24V AC	15	Buzzer	H	24VAC
7	Limit switch	SQ _(1~2)	10A	16	Transformer	TC	24V AC
8	Hydraulic solenoid valve	Y1	24V AC	17	Intermediate relay	KA	24VAC
9	Air solenoid valve	Y2	24V AC	18	Power indicator	R	24VAC

E. Leveling two platforms and install anchor bolts.

1. Check by level bar and use the shim to adjust the platforms until two platforms are in the same level.

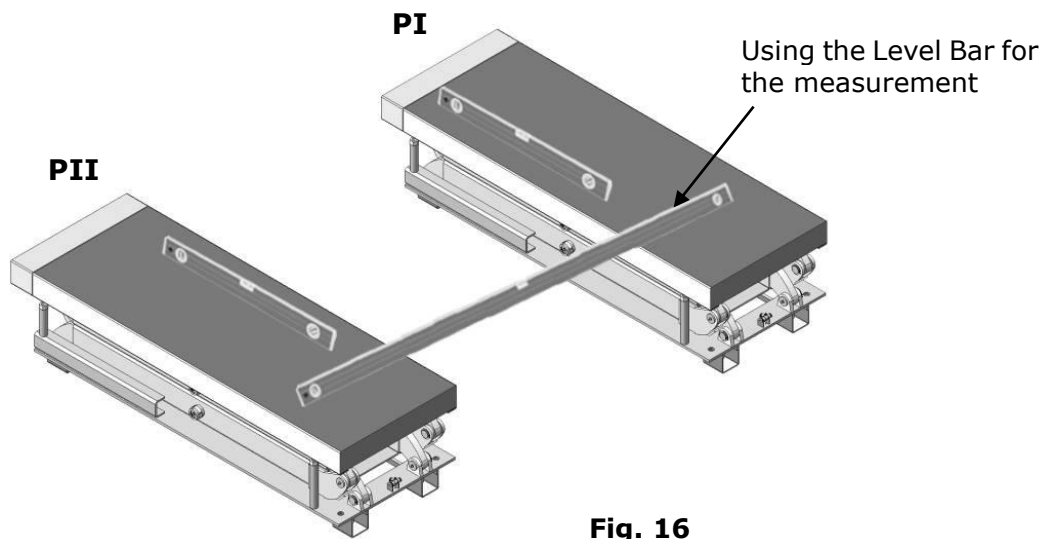

2. Install anchor bolts.

- 2.1 Raise the lift to 1000mm then drill holes to install the anchor bolts (**See Fig.17**).

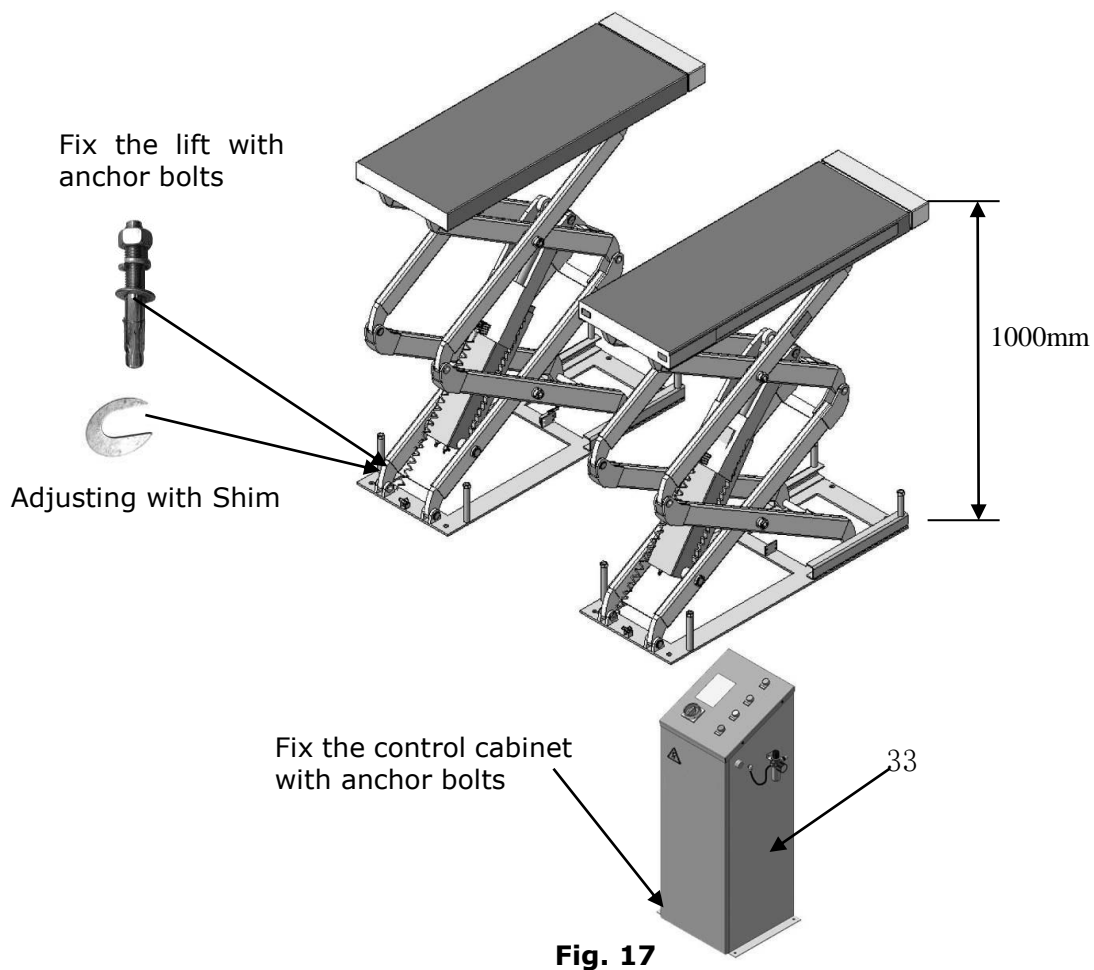

2.2 Fix the Anchor bolts (3/4×5 1/2).

Drilling the hole for the anchor bolt with the rotary hammer drill, type the anchor bolt into the ground, and then fasten it with Ratchet spanner (**See Fig. 18**).

Note: The torque of anchor bolt is 150N.m, the length inside ground of anchor bolt must be over 90mm.

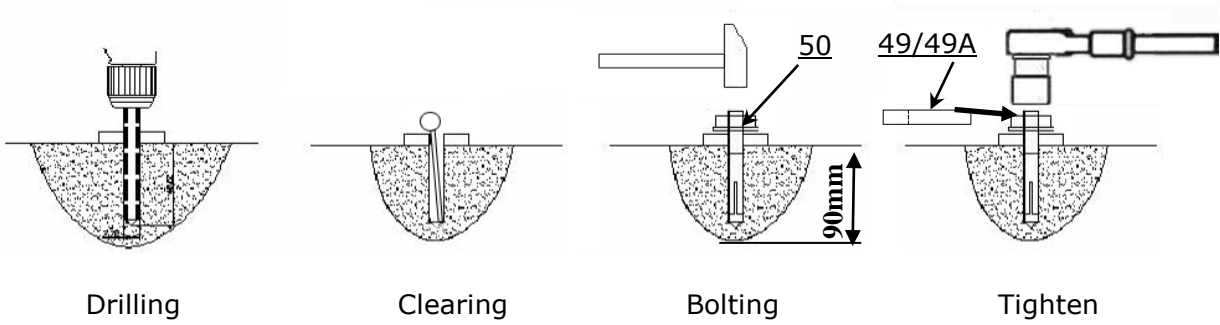

Fig. 18

3. Fix the control cabinet anchor bolts (M10×100mm) (**See Fig. 19**).

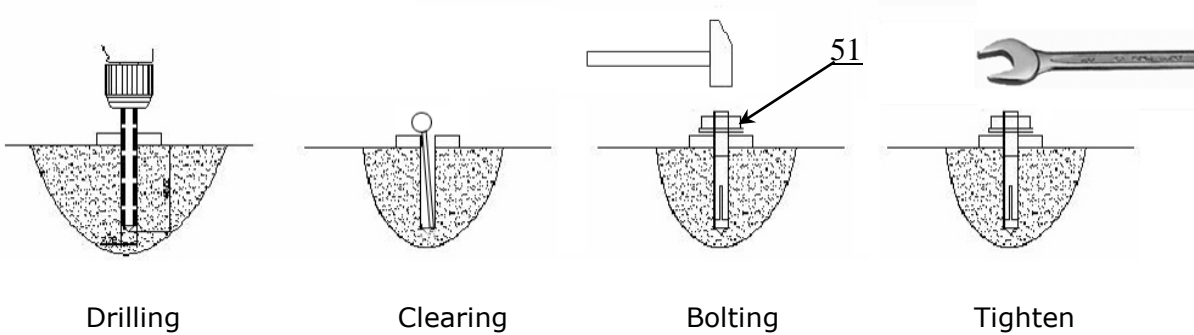

Fig. 19

IV. EXPLODED VIEW

MODEL TX8F

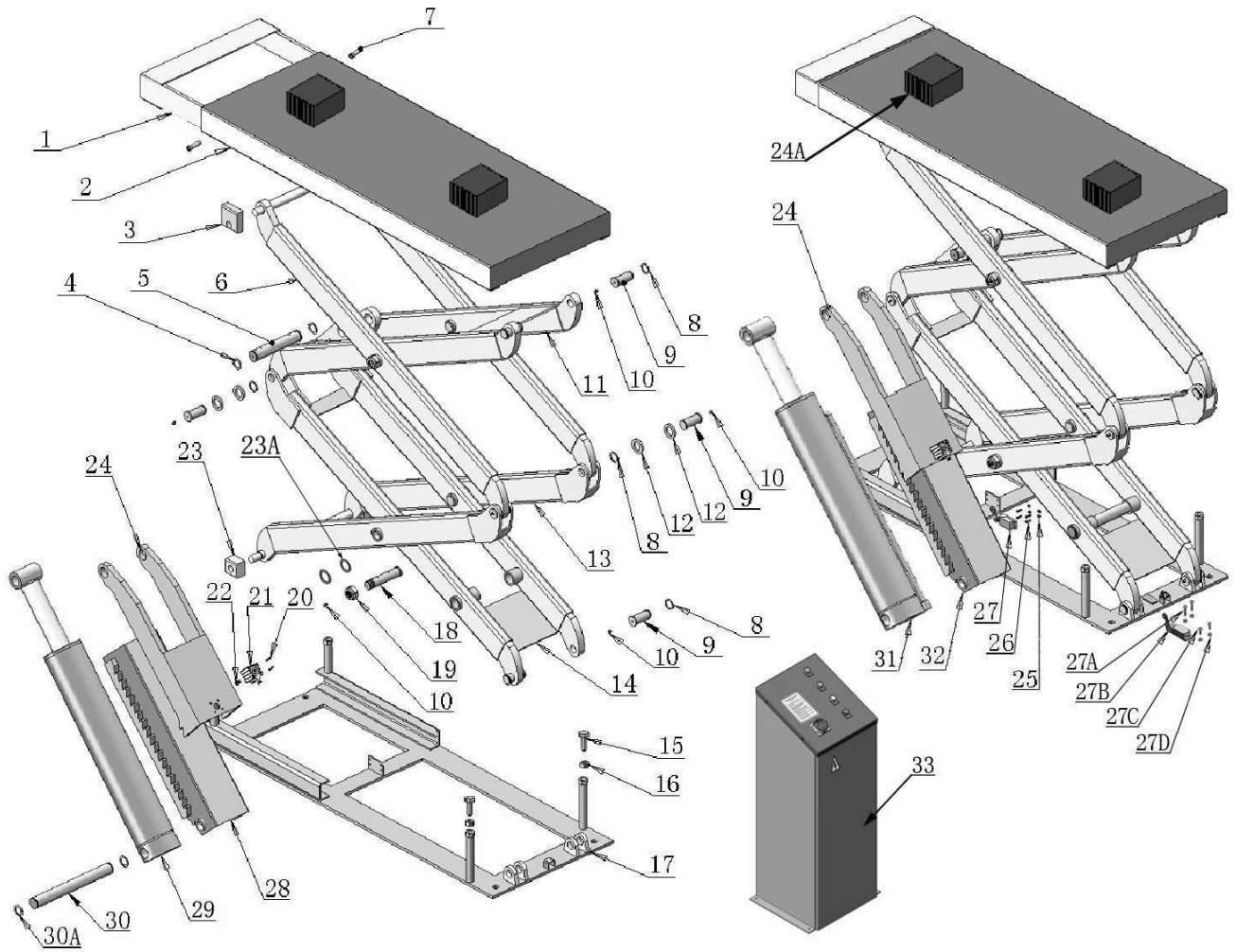

Fig. 20

CYLINDERS

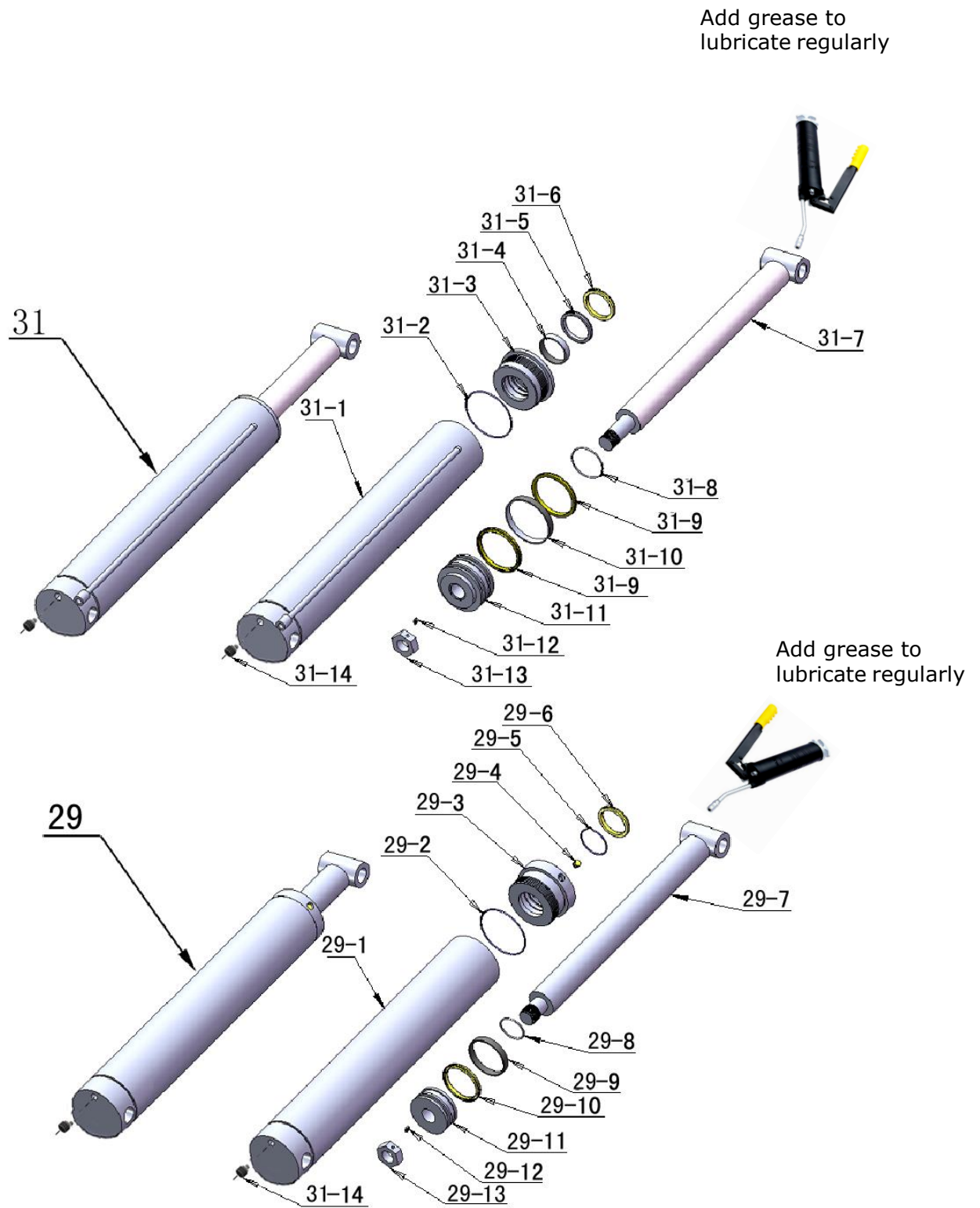

Fig. 21

CONTROL CABINET

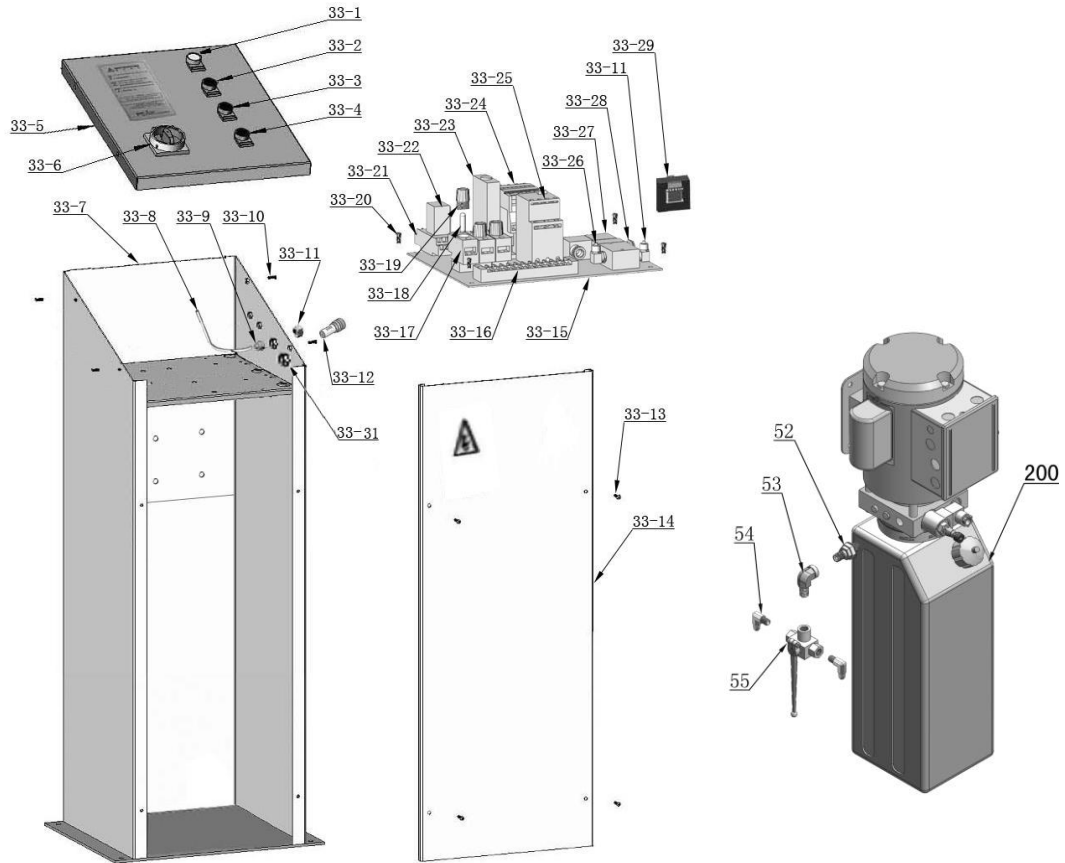

Fig. 22

SPX ELECTRIC POWER UNIT 220V/50HZ/1 Phase

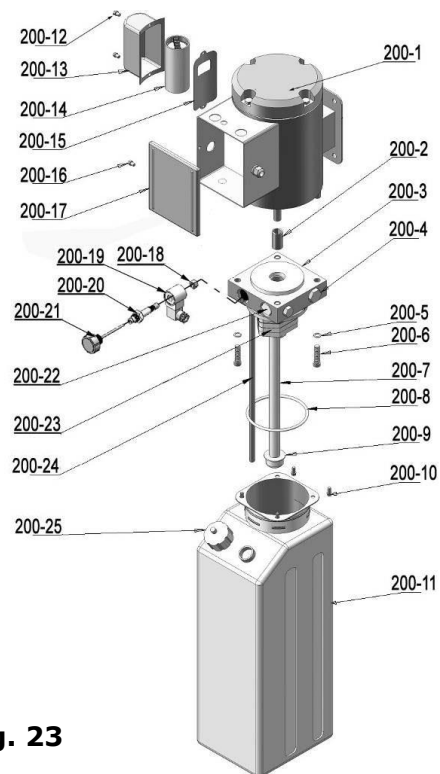

Fig. 23

INDYPRO ELECTRIC POWER UNIT (See Fig. 24)

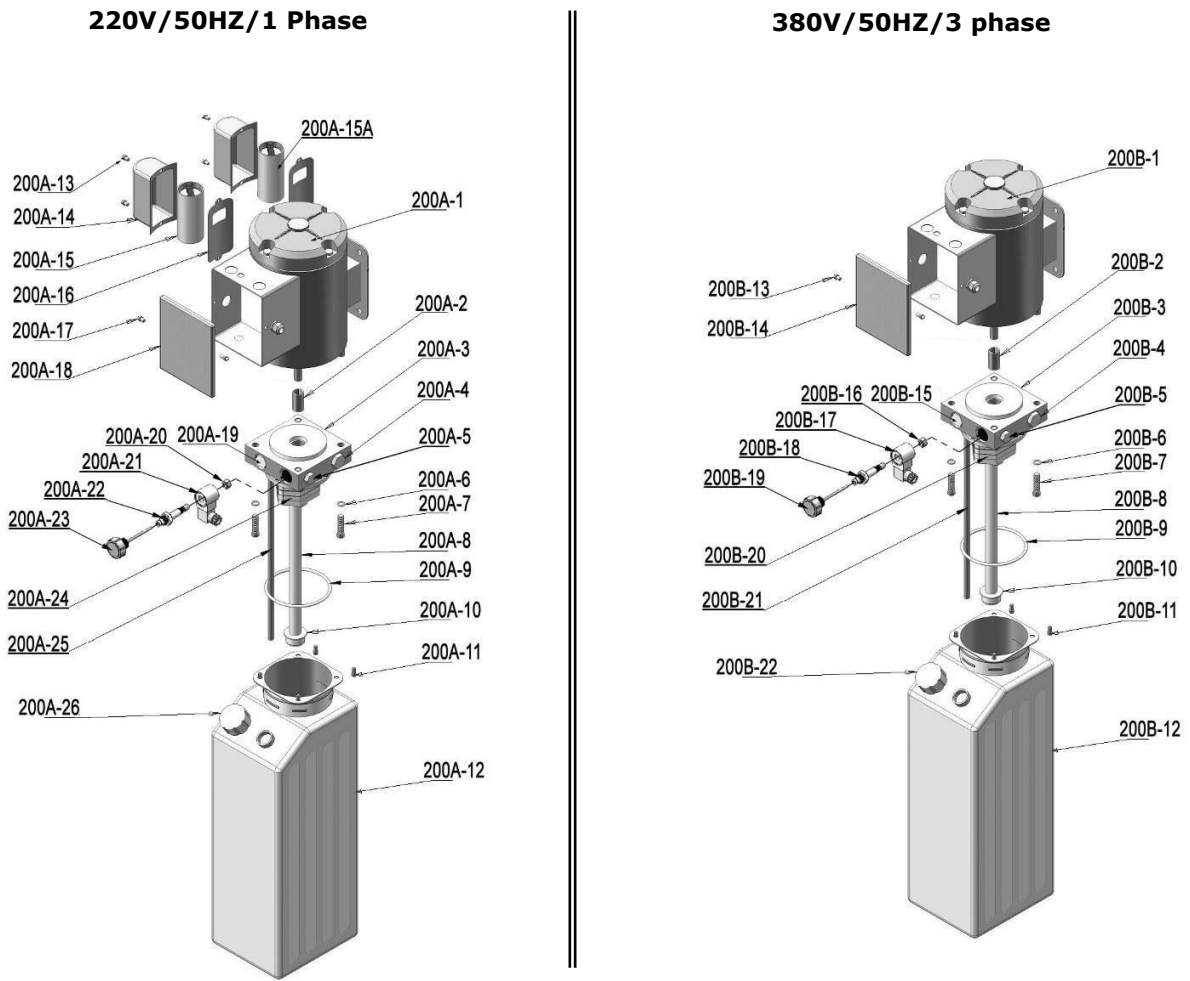

Fig. 24

Illustration of hydraulic valve for SPX & INDYPRO electric power unit

a. SPX Electric power unit, 220V/50HZ/1 phase (See Fig. 25)

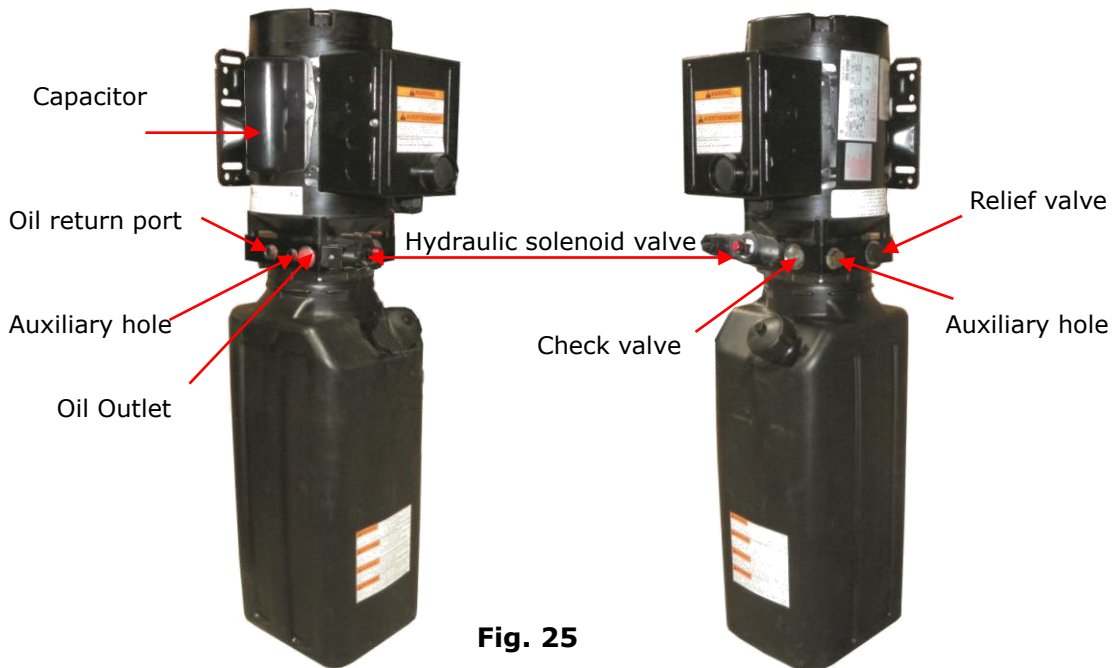

Fig. 25

b. INDYPRO Electric power unit, 220V/50HZ/1 phase (See Fig. 26)

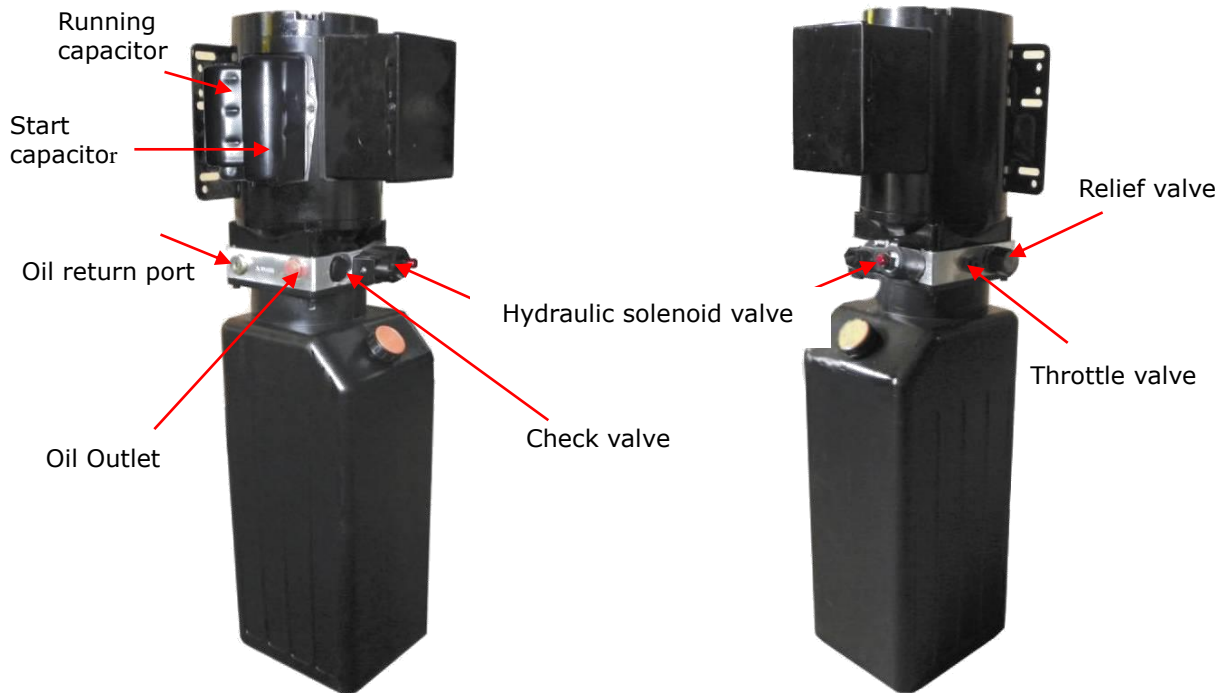

Fig. 26

c. INDYPRO Electric power unit, 380V/50HZ/3 phase (See Fig. 27)

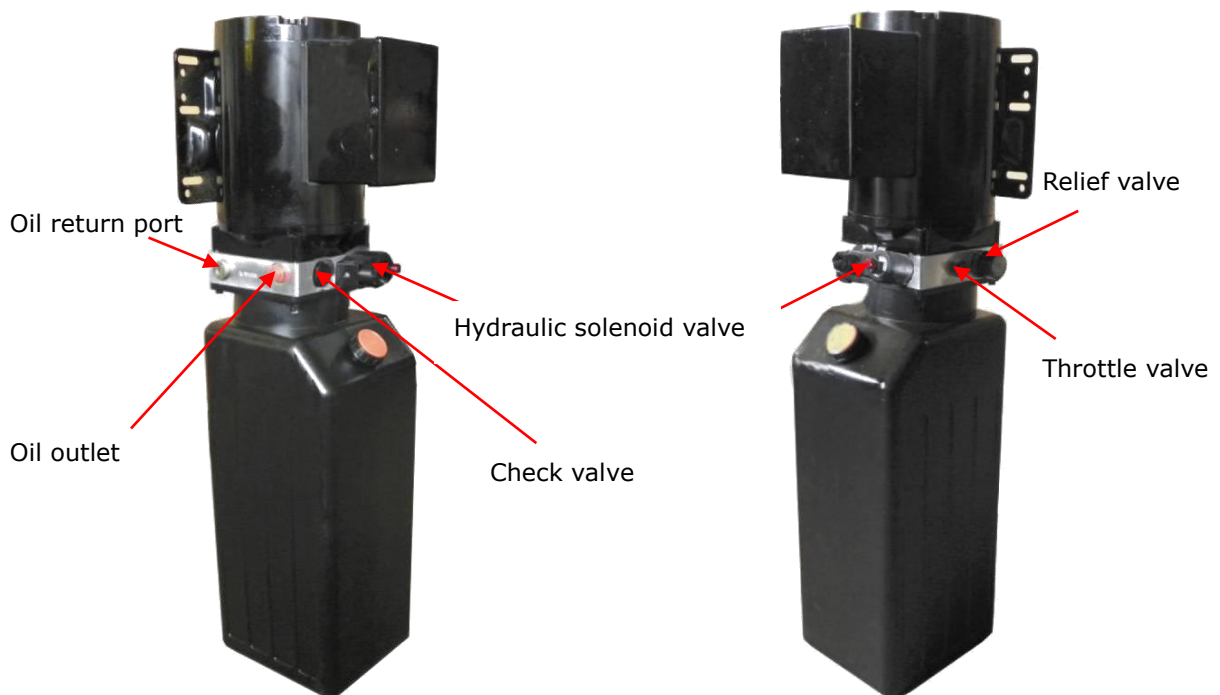
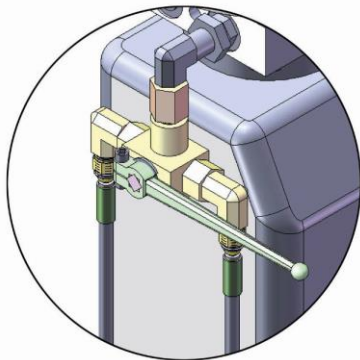

Fig. 27

V. TEST RUN

A. Fill oil to cylinder

1. Turn on the power, push the button **"Up"**, and check the rotated direction of the Motor. Exchange two source wire connection if the direction is reverse, and then follow the following procedure of filling oil to cylinders.
2. Fill reservoir with Hydraulic Oil (**Note: In consideration of power unit's durability, please use Hydraulic Oil 46#**).
3. Push the button **"Down"** until the both platforms down to the lowest position.
4. Turn the Two-way valve to the position connected to the secondly cylinder, push button **"Up"** and fill oil into the secondly cylinder till it is full, and then push button **"Lock"** for a while for bleeding air. Repeating this operation until no air in the hydraulic system (**See Fig. 28**).
5. Turn the Two-way valve to the main cylinder, push button **"Up"** to raise and lower the lift for several times, meanwhile do the synchronous adjustment till the two safety device can lock and release at the same time (**See Fig. 29**).



Oil Filling Position

Fig. 28

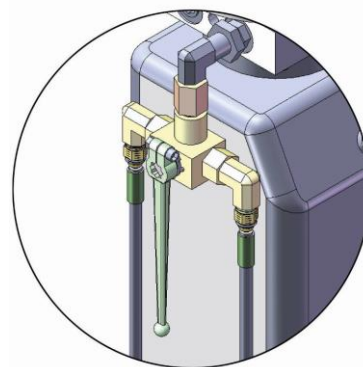

Normal Working Position

Fig. 29

B. Test run

Check the height limit switch, the hose and fitting connection, and do test run. The lift must be tested run and checked carefully before in use.

VI. OPERATION INSTRUCTIONS

To lift vehicle

1. Keep clear of site near the lift, and down the lift to the lowest position.
2. Drive vehicle to the platform and put on the brake.
3. Turn on the power and push the button "**UP**", raise the lift to the working position.

Note: make sure the vehicle is steady when the lift is rising

4. Push button "**Lock**" to lock the lift in the safety device. Make sure the safety is locked in the same height before working.

To lower vehicle

1. Be sure clear of around and under the lift, only leaving operator in lift area.
2. Push the button "**Down**", the lift is lowered continually and stopped at the height 600mm from ground. Keep feet clear off lift, push button "**DOWN**" while push the **Lowering Alarm Button(black)** at the side of control cabinet, the lift is lowered to ground with alarm tone;
3. Drive away the vehicle when the lift is lowered to the lowest position.
4. Turn off the power.

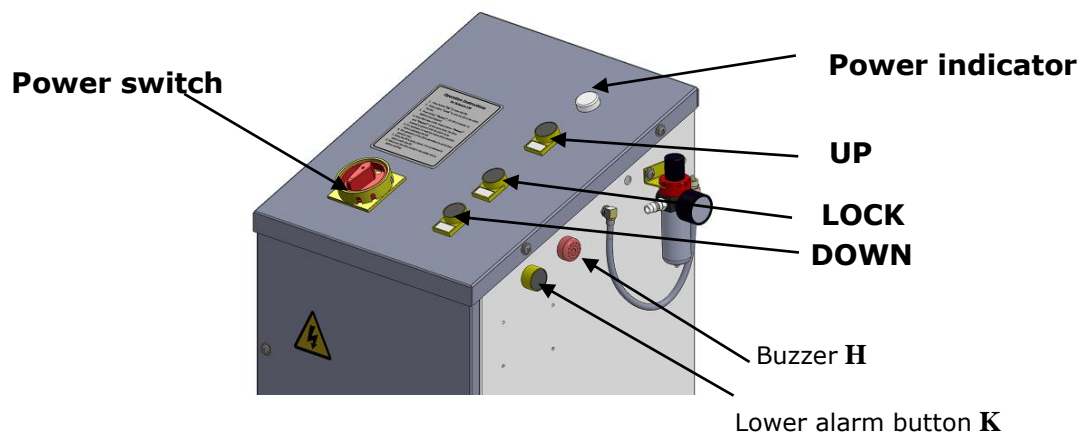

Fig. 30

VII.MAINTENANCE SCHEDULE

Monthly:

1. Re-torque the anchor bolts to 150 Nm.
2. Lubricate all moving parts with lubricant.
3. Check all fittings, bolts and pins to insure proper mounting.
4. Make a visual inspection of all hydraulic hoses/lines for possible wear or leakage.
5. Adjusting the lifting level on both platform.

Note: All anchor bolts should take full torque. If any of the bolts does not function for any reason, **DO NOT** use the lift until the bolt has been replaced.

Every six months:

1. Make a visual inspection of all moving parts for possible wear, interference or damage.
2. Check and adjust the platform as necessary to insure level lifting.
3. Check all fastener and re-torque.

VIII.TROUBLE SHOOTING

TROUBLE	CAUSE	REMEDY
Motor does not run	<ol style="list-style-type: none"> 1.Button does not work 2. AC contactor burned out 3. Motor burned out 	<ol style="list-style-type: none"> 1. Replace button 2. Replace AC contactor 3. Repair or replace motor
Motor have voice but not run	<ol style="list-style-type: none"> 1.Wiring connections of 3 phase are not in good condition. 2. AC contactor main contacts in poor contact 	<ol style="list-style-type: none"> 1. Check the 3 phase wiring connections, and repair it if not in good condition. 2. Replace AC contactor.
Motor runs but the lift is not raised	<ol style="list-style-type: none"> 1.Motor runs in reverse rotation 2.Low oil level 3.The Gear Pump out of operation 4.Relief valve or check valve in damage 5.Shaft Coupling in damage 	<ol style="list-style-type: none"> 1.Reverse two power wire 2.Fill tank 3.Repair or replace 4.Repair or replace 5.Replace Shaft Coupling
Lift raised slowly	<ol style="list-style-type: none"> 1.Oil line is jammed 2. Gear Pump leaks 3.Overload lifting 4.Power Voltage low 5.Oil mixed with air 	<ol style="list-style-type: none"> 1.Clean the oil line 2.Replace Pump 3.Check load 4.Check electrical system 5.Fill tank and bleeding air
Lift cannot lower	<ol style="list-style-type: none"> 1. Hydraulic Solenoid valve out of operation 2. Low Air pressure can't open the lock 	<ol style="list-style-type: none"> 1. Check Solenoid valve and Air line 2.Adjusting Air pressure of Compressor

IX. PARTS LIST FOR TX8F

Item	Part#	Description	QTY.	Note
1	610001A	Extended Platform	2	
2	610002A	Platform	2	
3	610003	Slider for platform	4	
4	610098	Snap Ring	4	
5	610005A	Cylinder Connecting Shaft	2	
6	610006A	Upper Scissor (Out)	2	
7	207021	Socket Bolt	4	
8	610008	Snap Ring	16	
9	610009A	Rotating Shaft B	16	
10	620064	Greasing Fitting	38	
11	610011B	Upper Scissor (In)	2	
12	610012	Washer	16	
13	610013B	Lower Scissor (Out)	2	
14	610014C	Lower Scissor (In)	2	
15	610095	Hex Bolt	8	
16	610096	Hex Nut	8	
17	610017A	Base frame	2	
18	610018	Rotating Shaft A	8	
19	610019	Self locking Nut	8	
20	420153	Cup Head Bolt	8	
21	520011	Air Cylinder	2	
22	680005	Cup Head Bolt	4	
23	610023	Slider For Base	4	
23A	610108	Washer	16	
24	610024A	Safety Lock (Upper)	2	
24A	610070	Rubber Pad	4	
25	420164	Cup Head Bolt	4	
27	610118	Limit Switch assy	1	
27A	420149	Cup Head Bolt	2	
27B	206013/ 610115	Limit Switch assy	1	
27C	620109	Cup Head Bolt	2	
27D	620095	Hex Nut	4	
28	610032A	Safety Lock Tube (Secondly)	1	
29	610031A	Secondly Cylinder	1	

Item	Part#	Description	QTY.	Note
30	610030A	Cylinder Pin	2	
30A	520023	Snap Ring	4	
31	610029A	Main Cylinder	1	
32	610028A	Safety Lock Tube (Main)	1	
33	610007A	Control Cabinet	1	
34	420047	Fitting for Air Line	2	
35	520065	Air Line (Spring)	2	
36	610114	Air Line	1	
37	420124	T-Fitting	1	
38	520069	90°Fitting For Air Line	1	
39	510023	Straight Fitting For Cylinder	2	
40	201022	T-Fitting For Cylinder	1	
41	610068	Oil Hose (No.3)	1	
42	610112	Oil Hose (No.1)	1	
43	610113	Oil Hose (No.2)	1	
200	610037	Electric Power Unit	1	
45	420076	90°Fitting For Air Line	1	
46	420145	Oil Water Separator	1	
47	420146	Air Line Fitting	1	
48	420018	Self locking nut	2	
49	620065	Shim(2 mm)	20	
49A	201090	Shim(1 mm)	20	
50	209059	Anchor Bolt	8	
51	620071	Anchor Bolt	4	
52	440009	Straight Fitting for Power Unit	1	
53	52K027	90° Fitting	1	
54	420097	90° Fitting	2	
55	61K018	Two-way Valve	1	
56	610500	Parts Box	1	
Parts for Hydraulic Cylinder				
31-1	610033	Main Cylinder	1	
31-2	520053	O- Ring	1	
31-3	520043	Head Cap (Main)	1	
31-4	520052	Support Ring	1	
31-5	520051	Y- Ring	1	
31-6	520050	Dust Ring	1	
31-7	610035	Piston Rod (Main)	1	
31-8	520054	O- Ring	1	
31-9	520055	Y- Ring	2	

Item	Part#	Description	QTY.	Note
31-10	520056	Support Ring	1	
31-11	520045	Piston (Main)	1	
31-12	520049	Set Screw	2	
31-13	520047	Hex Nut	1	
31-14	530009	Hose Burst Valve	2	
29-1	610034	Secondly Cylinder	1	
29-2	520060	O- Ring	1	
29-3	520044	Head Cap (Secondly)	1	
29-4	201034	Bleeding Plug	3	
29-5	520058	O- Ring	1	
29-6	520057	Dust Ring	1	
29-7	610036	Piston Rod (Secondly)	1	
29-8	520061	O- Ring	1	
29-9	520062	Support Ring	1	
29-10	520063	Y- Ring	1	
29-11	520046	Piston (Secondly)	1	
29-12	520049	Set Screw	1	
29-13	520048	Hex Nut	1	
Parts for Control Cabinet				
33-1	61K077	Power indicator	1	
33-2	420071	Button UP	1	
33-3	420071	Button LOCK	1	
33-4	420072	Button DOWN	1	
33-5	52K001B	Control Panel	1	
33-6	420074	Power Switch (QS)	1	
33-7	610109	Cabinet Body	1	
33-8	420167C	Air Line	2	
33-9	61K110	Straight Fitting For Air Line	1	
33-10	209145	Cup Head Bolt	4	
33-11	420076	90° Fitting For Air Line	2	
33-12	420143	Buzzer	1	
33-13	52K056	Cup Head Bolt	4	
33-14	52K022A	Cabinet Door	1	
33-15	52K006A	Panel for Installing Element	1	
33-16	620082	Terminal	1	
33-17	420087	Fuse Base	3	
33-18	420086	Fuse(FU)	3	
33-19	420085	Fuse Cap	3	

Item	Part#	Description	QTY.	Note
33-20	61K052	Cup head bolt	19	
33-21	420135	Timer Relay Base	2	
33-22	420141	Intermediate Relay(KA)	1	
33-23	420083	Timer Relay(KT)	1	
33-24	420084A	AC Contactor (KM)	1	
33-25	420140	Thermal Relay(FR)	1	
33-26	420166	90° Fitting	1	
33-27	420077	Air Solenoid Valve(Y2)	1	
33-28	201034	Bleeding plug	1	
33-29	420134	Transformer (TC)	1	
33-30	540008	Protective Ring	2	
33-31	420142	Lowering Alarm Button (Black)	1	
Parts For SPX Electric Power Unit 220V/50HZ/1 Phase				
200-1	81400185	Motor	1	
200-2	81400063	Motor Connecting Shaft	1	
200-3	81400186	Valve Body	1	
200-4	81400160	Relief Valve	1	
200-5	81400161	Lock Washer	4	
200-6	81400162	Socket Bolt	4	
200-7	81400121	Oil Inlet Pipe	1	
200-8	81400163	O-Ring	1	
200-9	81400164	Filter	1	
200-10	81400165	Hex Bolt	4	
200-11	81400093	Reservoir	1	
200-12	81400166	Cross Bolt	2	
200-13	81400167	Cover of Capacitor	1	
200-14	81400029	Capacitor	1	
200-15	81400168	Rubber Gasket	1	
200-16	81400169	Hex Bolt	1	
200-17	81400062	Cover of Motor Terminal Box	1	
200-18	81400187	Hydraulic Solenoid Valve Nut	1	
200-19	81400188	Hydraulic Solenoid Valve Coil	1	
200-20	81400056	Hydraulic Solenoid Valve Body	1	
200-21	81400189	Release Valve Adjusting Rod	1	
200-22	81400043	Check Valve	1	
200-23	81400123	Gear Pump	1	
200-24	81400122	Oil Return Pipe	1	
200-25	81400172	Filler Cap	1	

Parts For INDYPRO Electric Power Unit 220V/50HZ/1 Phase				
Item	Part#	Description	QTY.	Note
200A-1	81400190	Motor	1	
200A-2	81400127	Motor Connecting Shaft	1	
200A-3	81400198	Valve Body	1	
200A-4	81400106	Relief Valve	1	
200A-5	81400107	Throttle Valve	1	
200A-6	209149	Lock Washer	4	
200A-7	81400148	Socket Bolt	4	
200A-8	81400134	Oil Inlet Pipe	1	
200A-9	81400144	O-ring	1	
200A-10	81400150	Filter	1	
200A-11	81400145	Socket Bolt	4	
200A-12	81400024	Reservoir	1	
200A-13	420148	Cup Head Bolt with washer	4	
200A-14	81400066	Cover for Capacitor	2	
200A-15	81400130	Start Capacitor	1	
200A-15A	81400088	Run Capacitor	1	
200A-16	81400180	Rubber Gasket	2	
200A-17	420148	Cup Head Bolt with washer	2	
200A-18	81400050	Cover of Motor Terminal Box	1	
200A-19	81400192	Check Valve	1	
200A-20	81400193	Hydraulic Solenoid Valve Nut	1	
200A-21	81400194	Hydraulic Solenoid Valve Coil	1	
200A-22	81400195	Hydraulic Solenoid Valve Body	1	
200A-23	81400196	Pressure Adjusting Bar	1	
200A-24	81400041	Gear Pump	1	
200A-25	81400084	Oil Return Pipe	1	
200A-26	81400113	Filler Cap	1	

Parts For INDYPRO Electric Power Unit 380V/50HZ/3 Phase				
Item	Part#	Description	QTY.	Note
200B-1	81400197	Motor	1	
200B-2	81400127	Motor Connecting Shaft	1	
200B-3	81400198	Valve Body	1	
200B-4	81400106	Relief Valve	1	
200B-5	81400107	Throttle Valve	1	
200B-6	209149	Lock Washer	4	
200B-7	81400148	Socket Bolt	4	
200B-8	81400134	Oil Inlet Pipe	1	
200B-9	81400144	O-ring	1	
200B-10	81400150	Filter	1	
200B-11	81400145	Socket Bolt	4	
200B-12	81400024	Reservoir	1	
200B-13	420148	Cup Head Bolt with washer	2	
200B-14	81400050	Cover of Motor Terminal Box	1	
200B-15	81400192	Check Valve	1	
200B-16	81400193	Hydraulic Solenoid Valve Nut	1	
200B-17	81400194	Hydraulic Solenoid Valve Coil	1	
200B-18	81400195	Hydraulic Solenoid Valve Body	1	
200B-19	81400196	Pressure Adjusting Bar	1	
200B-20	81400041	Gear Pump	1	
200B-21	81400084	Oil Return Pipe	1	
200B-22	81400113	Filler Cap	1	



Exclusively for: TOMAD International, Inc. 8847 Commerce Park Place Suite A,
Indianapolis 46268 - USA Tel: (317) 8 7 0-1199 Fax: (317) 8 7 6 -7344
www.indypro.us